



**PASSENGER CAR DIAGRAMS**  
**ST PAUL MINN.**

**M.P. DEPT.**

**AUG. 18, 1945**

**No**

**80**

NEW	OLD	PAGE	KIND OF CAR	BUILD'R	DATE	NEW	OLD	PAGE	KIND OF CAR	BUILD'R	DATE	NEW	OLD	PAGE	KIND OF CAR	BUILD'R	DATE	NEW	OLD	PAGE	KIND OF CAR	BUILD'R	DATE
1	2102		St. P. & P. Pass-BAG	H. & B.	1882	52	300	5	B. M. & E.	A. C. & F.	1918	78	806	6	B. M. & E.	A. C. & F.	1913	109	157	9	B. M. & E.	B. & S.	1898
3	2123		" PASS	NYC & HR	"	53	301	"	"	"	"	79	807	"	"	"	"	110	111	10	"	"	1907
						54	302	"	"	"	"	80	808	"	"	"	"	111	112	"	"	"	"
23		1	MAIL	P. S. Co	1918	55	303	"	"	"	"	81	809	"	"	"	"	112	114	"	"	"	"
24		"	"	"	"	56	304	"	"	"	"	82	810	"	"	"	"	113	118	"	"	"	"
25		"	"	"	"	57	305	"	"	"	"	83	811	"	"	"	"	114	131	"	"	A. C. & F.	1911
26		"	"	"	"	58	306	"	"	"	"	84	812	"	"	"	"	115	135	"	"	"	"
27		"	"	"	"	59	307	"	"	"	"	85	813	"	"	"	"	116	136	"	"	"	"
28		"	"	"	"	60	308	"	"	"	"	86	814	"	"	"	"	117	137	"	"	"	"
29		"	"	"	"	61	309	"	"	"	"	87	815	"	"	"	"						
30		"	"	"	"	62	310	"	"	"	"	88	816	"	"	"	"						
31		"	"	"	"	63	311	"	"	"	"	89	817	"	"	"	"	148	102	11	B. M. & E.	A. C. & F.	1904
32		"	"	"	"	64	312	"	"	"	"	90	818	"	"	"	"	149	103	"	"	"	"
33		"	"	"	"	65	313	"	"	"	"	91	819	"	"	"	"	150	612	12	"	B. & S.	1898
34		"	"	"	"	66	314	"	"	"	"	92	820	"	"	"	"	151	614	"	"	"	"
35		"	"	"	"	67	315	"	"	"	"	93	821	"	"	"	"						
36		"	"	"	"	68	316	"	"	"	"							181	1209	13	B. & M.	B. & S.	1914
						69	317	"	"	"	"	100	173	7	B. & M.	A. C. & F.	1906	182	1210	"	"	"	"
44	222	2	BAG & MAIL	B. & S.	1914	70	318	"	"	"	"	101	174	"	"	"	"	183	220	"	"	"	"
45	223	"	"	"	"	71	319	"	"	"	"	102	175	"	"	"	"	184	1211	"	"	"	"
46	225	"	"	"	"	72	800	6	"	"	1913	103	176	"	"	"	"	185	221	"	"	"	"
47	224	"	"	"	"	73	801	"	"	"	"	104	178	"	"	"	"	188	233	"	"	"	"
48	232	3	"	"	"	74	802	"	"	"	"	105	180	"	"	"	"	189	236	"	"	"	"
49	234	"	"	"	"	75	803	"	"	"	"	106	153	8	B. M. & E.	B. & S.	1898	190	228	"	"	"	"
50	200	4	B. M. & E.	"	"	76	804	"	"	"	"	107	154	"	"	"	"	191	227	"	"	"	"
51	201	"	"	"	"	77	805	"	"	"	"	108	155	9	"	"	"	192	226	"	"	"	"

5-26-43



NEW	OLD	PAGE	KIND OF CAR	BUILD'R	DATE	NEW	OLD	PAGE	KIND OF CAR	BUILD'R	DATE	NEW	OLD	PAGE	KIND OF CAR	BUILD'R	DATE	NEW	OLD	PAGE	KIND OF CAR	BUILD'R	DATE
206	249	14	MAIL STORAGE	A.C.&F	1904	232	384	22	B & E.	A.C.&F	1906	336	1106	28	BAGGAGE	A.C.&F	1913	365	1261	31	B. & E.	B.&S.	1909
207	262	15	"	B.&S.	1911	233	387	24	"	"	1902	337	1107	29	"	"	"						
208	268	16	B. & E.	"	1896	234	392	22	"	"	1906	338	1108	28	"	"	"	372	1673	33	B. & E.	B.&S.	1909
209	275	17	"	A.C.&F	1905	235	393	"	"	"	"	339	1109	29	"	"	"	373	1251	"	"	"	"
210	278	"	"	"	"	236	394	"	"	"	"	340	1110	"	"	"	"	377	1255	"	"	"	"
211	281	18	"	B.&S.	"							341	1111	"	"	"	"	378	1256	"	"	"	"
212	285	"	"	"	"	241	471	25	BAGGAGE	A.C.&F	1910	342	1112	"	"	"	"	379	1257	"	"	"	"
213	291	19	BAGGAGE	"	1893	242	475	26	"	"	1904	343	1113	"	"	"	"	380	1258	"	"	"	"
214	304	20	"	"	1907	243	476	"	"	"	"	344	1114	30	"	"	"						
215	306	"	"	"	"	244	477	"	"	"	"	345	1115	29	"	"	"	399	1710	34	BAGGAGE	A.C.&F	1906
216	311	"	"	"	"	245	478	"	"	"	"	346	1116	"	"	"	"	400	8211	35	"	B.&S.	1907
217	313	"	"	"	"	246	479	"	"	"	"	347	1117	"	"	"	"	401	8214	"	"	"	"
218	316	"	"	"	1911	247	481	"	"	"	"	348	1118	"	"	"	"	402	8218	"	"	"	"
219	317	"	"	"	"	248	482	"	"	"	1906	349	1119	"	"	"	"	403	8219	"	"	"	"
220	318	"	"	"	"							350	1689	31	B & E.	B.&S.	1909	404	8220	"	"	"	"
221	320	"	"	"	"	259	—	26A	BAGGAGE			351	1151	"	"	"	"	405	8224	"	"	"	1910
222	321	"	"	"	"	260	235	27	BAGGAGE	B.&S.	1914	352	1152	"	"	"	"	406	8225	"	"	"	"
223	323	"	"	"	"	261	237	"	"	"	"	353	1153	"	"	"	"	407	8226	"	"	"	"
224	324	"	"	"	"							354	1154	"	"	"	"	408	8231	"	"	"	"
225	325	"	"	"	"							355	1155	"	"	"	"	409	8232	"	"	"	"
226	329	"	"	"	"	330	1100	28	BAGGAGE	A.C.&F	1913	356	1156	"	"	"	"	410	B-13	"	"	"	"
227	361	21	B. & E.	"	1909	331	1101	29	"	"	"	357	1157	"	"	"	"	411	B-14	"	"	"	"
228	366	22	"	A.C.&F	1906	332	1102	"	"	"	"	358	1158	32	"	"	"	412	B-15	"	"	"	"
229	369	23	BAG	"	1902	333	1103	"	"	"	"	360	1160	31	"	"	"	413	8236	"	"	"	"
230	371	"	"	"	"	334	1104	30	"	"	"	362	1702	"	"	"	"	414	8237	"	"	"	"
231	374	21	B & E.	B.&S.	1909	335	1105	29	"	"	"	364	1260	"	"	"	"	415	8238	"	"	"	"

5-26-43. REV 12-14-44

NEW	OLD	PAGE	KIND OF CAR	BUILD'R	DATE	NEW	OLD	PAGE	KIND OF CAR	BUILD'R	DATE	NEW	OLD	PAGE	KIND OF CAR	BUILD'R	DATE	NEW	OLD	PAGE	KIND OF CAR	BUILD'R	DATE
416	8239	35	BAGGAGE	B. & S.	1910	443	1013	46	BAGGAGE	B. & S.	1909	500	2163	53	PASS. & BAG.	B. & S.	1890	564	849	67	PASS. & BAG.	B. & S.	1910
417	8241	"	"	"	"	444	1024	"	"	"	1911	506	2146	54	"	"	1879	565	643	68	"	A.C. & F.	1913
418	B-17	"	"	"	"	445	1014	"	"	"	1909	514	2161	55	"	"	1889	566	644	"	"	"	"
419	653	36	"	A.C. & F.	1913	446	1015	"	"	"	"	518	2172	56	"	"	1883	567	649	"	"	"	"
420	1002	37	"	PULL.	1905	447	1010	"	"	"	"	519	2173	"	"	"	"	568	2312	69	"	EL. M. Co.	1925
421	1003	"	"	"	"	448	1011	"	"	"	"	521	2175	"	"	"	"	569	641	70	"	B. & S.	1910
422	1004	"	"	"	"	449	1017	"	"	"	1910	526	2180	"	"	"	"	570	642	"	"	"	"
423	1005	"	"	B. & S.	1906	450	1020	"	"	"	"	536	2194	57	"	"	1879	571	645	"	"	"	"
424	1006	"	"	"	1908	451	1019	"	"	"	"	539	2166	58	"	PULL.	1888						
425	1007	"	"	"	"	452	1025	"	"	"	1911	541	601	59	"	B. & S.	1901	582	3250	71	Comb. Cch.	B. & S.	1906
426	1008	"	"	"	"	453	1026	"	"	"	"	545	603	60	"	"	"	583	3251	"	"	"	"
427	A-24	38	"	"	1882	454	1028	"	"	"	"	549	606	61	"	"	1902	584	3252	"	"	"	"
428	A-26	39	"	G. N. Ry	1910	455	1021	"	"	"	1910	550	609	"	"	"	"						
429	A-12	40	"	B. & S.	1893	456	1022	"	"	"	1911	551	738	62	"	"	"						
430	A-8	41	"	"	"	457	1023	"	"	"	"	552	739	"	"	"	"						
432	1111	42	"	"	1911	458	1027	"	"	"	"	553	822	63	"	"	1910	617	3500	72	SMOKER	B. & S.	1905
433	1112	"	"	"	"	460	B-3	47	"	"	1906	554	837	"	"	"	"	618	3502	"	"	"	"
434	1115	"	"	"	"	461	B-4	"	"	"	"	555	839	"	"	"	"	619	3504	"	"	"	"
435	1105	"	"	"	1909							556	819	"	"	"	"	622	3507	"	"	"	"
436	1108	"	"	"	1911	468	107	48	BAGGAGE	A.C. & F.	1906	557	848	"	"	"	"	623	3508	"	"	"	"
437	A-29	43	"	"	1893	469	108	49	"	"	"	558	844	"	"	"	"	624	3509	"	"	"	"
438	1116	44	"	"	1911	474	123	48	"	"	1910	559	638	64	"	"	"	626	3511	"	"	"	1906
439	480	45	"	A.C. & F.	1904							560	637	65	"	"	1907	628	3514	"	"	"	"
440	1018	46	"	B. & S.	1910							561	636	"	"	"	"	629	3515	"	"	"	"
441	1016	"	"	"	1909							562	633	66	"	"	"	630	3516	"	"	"	"
442	1012	"	"	"	"							563	842	67	"	"	1910	631	3517	"	"	"	"

NEW	OLD	PAGE	KIND OF CAR	BUILD'R	DATE	NEW	OLD	PAGE	KIND OF CAR	BUILD'R	DATE	NEW	OLD	PAGE	KIND OF CAR	BUILD'R	DATE	NEW	OLD	PAGE	KIND OF CAR	BUILD'R	DATE
646	3703	73	2 <sup>ND</sup> C.C. & SLEEP'R	A.C. & F.	1913	765	911	78	Comb. Coach	B. & S.	1905	870	804	79	1 <sup>ST</sup> CL. COACH	B. & S.	1910	896	751	82	Comb Coach	B. & S.	1902
647	3704	"	"	"	"	766	917	"	"	PULL.	1906	871	805	"	"	"	"	897	752	"	"	"	"
648	3705	"	"	"	"	767	918	"	"	"	"	872	806	"	"	"	"	898	753	"	"	"	"
650	3707	"	"	"	"							873	807	"	"	"	"	899	873	"	"	"	1907
651	3708	"	"	"	"							874	808	"	"	"	"	900	4402	83	1 <sup>ST</sup> CL. COACH	"	1905
652	3709	"	"	"	"							875	809	"	"	"	"	901	4403	"	"	"	"
654	3711	"	"	"	"	850	813	79	1 <sup>ST</sup> CL. COACH	B. & S.	1910	876	810	"	"	"	"	902	4254	"	"	"	"
655	3712	"	"	"	"	851	814	"	"	"	"	877	811	"	"	"	"	903	4405	"	"	"	"
656	3713	"	"	"	"	852	818	"	"	"	"	878	812	"	"	"	"	904	4406	"	"	"	"
657	3714	"	"	"	"	853	820	"	"	"	"	879	827	"	"	"	"	905	4407	"	"	"	"
658	3715	"	"	"	"	854	821	"	"	"	"	880	833	"	"	"	"	906	4408	"	"	"	"
659	3716	"	"	"	"	855	824	"	"	"	"	881	714	81	Comb Coach	"	1901	907	4409	"	"	"	"
666	3723	"	"	"	"	856	831	"	"	"	"	882	717	"	"	"	"	908	4410	"	"	"	"
667	3724	"	"	"	"	857	835	"	"	"	"	883	718	"	"	"	"	909	4411	"	"	"	"
668	3725	74	2 <sup>ND</sup> CL. COACH	B. & S.	1910	858	836	"	"	"	"	884	719	"	"	"	"	910	4412	"	"	"	"
669	3726	"	"	"	"	859	840	"	"	"	"	885	723	"	"	"	"	911	1074	84	"	"	1909
						860	852	"	"	"	"	886	725	"	"	"	"	912	1075	85	"	"	1910
712	4012	75	Comb. Coach	A.C. & F.	1912	861	732	80	"	"	"	887	750	82	"	"	1902	913	1076	86	"	"	"
						862	733	"	"	"	"	888	754	"	"	"	"	914	1078	87	"	"	"
758	4400	76	Comb. Coach	B. & S.	1905	863	734	"	"	"	"	889	755	"	"	"	1907	915	1079	"	"	"	"
759	4401	"	"	"	"	864	735	"	"	"	"	890	756	"	"	"	"	916	1077	86	"	"	"
760	913	77	"	PULL.	1906	865	736	"	"	"	"	891	740	"	"	"	1902	917	1087	88	"	"	"
761	915	"	"	"	"	866	737	"	"	"	"	892	743	"	"	"	"	918	1088	"	"	"	"
762	914	78	"	"	"	867	800	79	"	"	"	893	746	"	"	"	"	919	1091	"	"	"	"
763	916	"	"	"	"	868	802	"	"	"	"	894	748	"	"	"	"	920	8250	89	"	"	"
764	912	"	"	"	"	869	803	"	"	"	"	895	749	"	"	"	"	921	8249	"	"	"	"



NEW	OLD	PAGE	KIND OF CAR	BUILD'R	DATE	NEW	OLD	PAGE	KIND OF CAR	BUILD'R	DATE	NEW	OLD	PAGE	KIND OF CAR	BUILD'R	DATE	NEW	OLD	PAGE	KIND OF CAR	BUILD'R	DATE
922	8248	89	1 <sup>ST</sup> CL. COACH	B. & S.	1910	950	4500	92	1 <sup>ST</sup> CL. COACH	B. & S.	1914	976	4526	94	1 <sup>ST</sup> CL. COACH	B. & S.	1914	1030		101	DINING	PULL.	1924
923	8247	"	"	"	"	951	4501	"	"	"	"	977	4527	95	"	"	"	1031	"	"	"	"	"
924	8246	"	"	"	"	952	4502	"	"	"	"	978	4528	96	"	"	"	1032	"	"	"	"	"
925	8245	"	"	"	"	953	4503	"	"	"	"	979	4529	96	"	"	"	1033	"	"	"	"	"
926	8244	"	"	"	"	954	4504	"	"	"	"				"	"	"	1034	"	"	"	"	"
927	8243	"	"	"	"	955	4505	"	"	"	"				"	"	"	1035	"	"	"	"	"
928	919	90	"	"	1907	956	4506	"	"	"	"				"	"	"	1036	"	"	"	"	"
930	884	83	"	"	"	957	4507	"	"	"	"				"	"	"	1037	"	"	"	"	"
931	885	"	"	"	"	958	4508	"	"	"	"				"	"	"	1038	"	"	"	"	1925
						959	4509	"	"	"	"	990		97	1 <sup>ST</sup> CL. COACH	PULL.	"	1039	"	"	"	"	"
						960	4510	"	"	"	"	991		"	"	"	"	1040	"	"	"	"	1926
						961	4511	"	"	"	"	992		"	"	"	"	1041	"	"	"	"	"
						962	4512	"	"	"	"	993		"	"	"	"	1042	"	"	"	"	1929
						963	4513	"	"	"	"	994		"	"	"	"	1043	"	"	"	"	"
938		91	1 <sup>ST</sup> CL. COACH	PULL.	1937	964	4514	93	"	"	"	995		"	"	"	"	1044	"	"	"	"	"
939		"	"	"	"	965	4515	92	"	"	"				"	"	"	1045	"	"	"	"	"
940		"	"	"	"	966	4516	"	"	"	"				"	"	"	1046	"	"	"	"	"
941		"	"	"	"	967	4517	93	"	"	"				"	"	"	1047	"	"	"	"	"
942		"	"	"	"	968	4518	"	"	"	"	999		98	1 <sup>ST</sup> CL. COACH	P.R.E. CO.	1942	1048	"	"	"	"	"
943		"	"	"	"	969	4519	"	"	"	"	1000	662	99	SL. SM. COACH	A.C. & F.	1913	1049	"	"	"	"	"
944		"	"	"	"	970	4520	"	"	"	"	1001	663	"	"	"	"	1050	"	"	"	"	1930
945		"	"	"	"	971	4521	"	"	"	"	1002	661	100	"	"	"	1051	"	"	"	"	"
946		"	"	"	"	972	4522	"	"	"	"	1003	664	"	"	"	"		"	"	"	"	"
947		"	"	"	"	973	4523	"	"	"	"	1004	665	"	"	"	"		"	"	"	"	"
948		"	"	"	"	974	4524	94	"	"	"				"	"	"		"	"	"	"	"
949		"	"	"	"	975	4525	"	"	"	"				"	"	"		"	"	"	"	"



3-1-26 Rev. 6-1-30. Rev. 12-18-31. Rev. 9-30-33. 5-26-43

NEW	OLD	PAGE	KIND OF CAR	BUILD'R	DATE	NEW	OLD	PAGE	KIND OF CAR	BUILD'R	DATE	NEW	OLD	PAGE	KIND OF CAR	BUILD'R	DATE	NEW	OLD	PAGE	KIND OF CAR	BUILD'R	DATE
1900		110	EXP. REFG.	B.&S.	1914	1926		110	EXP. REFG.	B.&S.	1914	1965		111	EXP. REFG.	A.C.&F.	1907	2008		110	EXP. REFG.	A.C.&F.	1910
1901		"	"	"	"	1927		"	"	"	"	1966		"	"	"	"	2009		"	"	"	"
1902		"	"	"	"	1928		"	"	"	"	1967		"	"	"	"	2010		"	"	G.N.Ry	1912
1903		"	"	"	"	1929		"	"	"	"	1968		"	"	"	"	2011		"	"	"	"
1904		"	"	"	"	1930		"	"	"	"	1969		"	"	"	"	<del>2012</del>				<del>B.&amp;S.</del>	
1905		"	"	"	"	1931		"	"	"	"	1970		"	"	"	"	2013		"	"	"	"
1906		"	"	"	"	1932	1957	"	"	A.C.&F.	1907	1971		"	"	"	"	2014		"	"	"	"
												1972		"	"	"	"	2015		"	"	"	"
1908		110	EXP. REFG.	B.&S.	1914							1973		"	"	"	"	2016		"	"	"	"
1909		"	"	"	"									"	"	"	"	2017		"	"	"	"
1910		"	"	"	"							1975		111	EXP. REFG.	A.C.&F.	1907	2018		"	"	"	"
1911		"	"	"	"	1950		111	EXP. REFG.	A.C.&F.	1907	1976		"	"	"	"	2019		"	"	"	"
1912		"	"	"	"	1951		"	"	"	"	1977		"	"	"	"	2020		"	"	"	"
1913		"	"	"	"	1952		"	"	"	1923	1978		"	"	"	"	2021		"	"	"	"
1914		"	"	G.N.Ry.	1919	1953		"	"	"	1907	1979		"	"	"	"	2022		"	"	"	"
1915		"	"	B.&S.	1914	1954		"	"	"	"			"	"	"	"	2023		"	"	"	"
1916		"	"	"	"	1955		"	"	"	"			"	"	"	"	2024		"	"	"	"
1917		"	"	"	"	1956		"	"	"	"			"	"	"	"	2025		"	"	"	"
1918		"	"	"	"							2000		110	EXP. REFG.	A.C.&F.	1910	2026		"	"	"	"
1919		"	"	"	"							2001		"	"	"	"	<del>2027</del>					
1920		"	"	"	"	1959		111	EXP. REFG.	A.C.&F.	1907	2002		"	"	"	"	2028		"	"	"	"
1921		"	"	"	"	1960		"	"	"	"	2003		"	"	"	"	2029		"	"	"	"
1922		"	"	"	"	1961		"	"	"	"	2004		"	"	"	"						
						1962		"	"	"	"	2005		"	"	"	"	2031		110	EXP. REFG.	B.&S.	1912
1924		110	EXP. REFG.	B.&S.	1914	1963		"	"	"	"	2006		"	"	"	"	2032		"	"	"	"
1925		"	"	"	"	1964		"	"	"	"	2007		"	"	"	"	2033		"	"	"	"



NEW	OLD	PAGE	KIND OF CAR	BUILD'R.	DATE	NEW	OLD	PAGE	KIND OF CAR	BUILD'R.	DATE	NEW	OLD	PAGE	KIND OF CAR	BUILD'R.	DATE	NEW	OLD	PAGE	KIND OF CAR	BUILD'R.	DATE
2034		110	Exp. Refg.	B. & S.	1912	2060		110	Exp. Refg.	B. & S.	1914	2086		110	Exp. Refg.	B. & S.	1914	2112		112	Exp. Refg.	S-S	1924
2035		"	"	"	"	2061		"	"	"	"	2087		"	"	"	"	2113		"	"	"	"
2036		"	"	"	"	2062		"	"	"	"	2088		"	"	"	"	2114		"	"	"	"
2037		"	"	"	"	2063		"	"	"	"	<del>2089</del>						2115		"	"	"	"
2038		"	"	"	"	2064		"	"	"	"	2090		112	"	S-S.	1924	2116		"	"	"	"
2039		"	"	"	"	2065		"	"	"	"	2091		"	"	"	"	2117		"	"	"	"
2040		"	"	"	"	2066		"	"	"	"	2092		"	"	"	"	2118		"	"	"	"
						2067		"	"	"	"	2093		"	"	"	"	2119		"	"	"	"
<del>2041</del>		<del>110</del>	<del>Exp. Refg.</del>	<del>B. &amp; S.</del>	<del>1912</del>	2068		"	"	"	"	2094		"	"	"	"	2120		"	"	"	"
<del>2042</del>		<del>"</del>	<del>"</del>	<del>"</del>	<del>"</del>	2069		"	"	"	"	2095		"	"	"	"	2121		"	"	"	"
2044		"	"	"	"	2070		"	"	"	"	2096		"	"	"	"	2122		"	"	"	"
2045		"	"	"	"	<del>2071</del>						2097		"	"	"	"	2123		"	"	"	"
2046		"	"	"	"	2072		"	"	"	"	2098		"	"	"	"	2124		"	"	"	"
2047		"	"	"	1914	2073		"	"	"	"	2099		"	"	"	"	2125		"	"	"	"
2048		"	"	"	"	2074		"	"	"	"	2100		"	"	"	"	2126		"	"	"	"
2049		"	"	"	"	2075		"	"	"	"	2101		"	"	"	"	2127		"	"	"	"
2050		"	"	"	"	2076		"	"	"	"	2102		"	"	"	"	2128		"	"	"	"
2051		"	"	"	"	2077		"	"	"	"	2103		"	"	"	"	2129		"	"	"	"
2052		"	"	"	"	2078		"	"	"	"	2104		"	"	"	"	2130		"	"	"	"
2053		"	"	"	"	2079		"	"	"	"	2105		"	"	"	"	2131		"	"	"	"
2054		"	"	"	"	2080		"	"	"	"	2106		"	"	"	"	2132		"	"	"	"
2055		"	"	"	"	2081		"	"	"	"	2107		"	"	"	"	2133		"	"	"	"
2056		"	"	"	"	2082		"	"	"	"	2108		"	"	"	"	2134		"	"	"	"
2057		"	"	"	"	2083		"	"	"	"	2109		"	"	"	"	2135		"	"	"	"
2058		"	"	"	"	2084		"	"	"	"	2110		"	"	"	"	2136		"	"	"	"
2059		"	"	"	"	2085		"	"	"	"	2111		"	"	"	"	2137		"	"	"	"

3-1-26. REV. 6-1-30. REV. 9-30-33. 5-26-43

NEW	OLD	PAGE	KIND OF CAR	BUILDER	DATE	NEW	OLD	PAGE	KIND OF CAR	BUILDER	DATE	NEW	OLD	PAGE	KIND OF CAR	BUILDER	DATE	NEW	OLD	PAGE	KIND OF CAR	BUILDER	DATE
2138		112	EXP. REF'G	S-S	1924	2522		132	Box-EXPR.	G.N.RY.	1944	1		129	HEATER	St.L.C.Co	1928						
2139		"	"	"	"	2523		"	"	"	"	2		"	"	"	"						
						2524		"	"	"	"	3		"	"	"	"						
												4		"	"	"	"						
2500		132	Box-EXP.	G.N.RY.	1944							5	100/	130	"	G.N.RY	1929						
2501		"	"	"	"	A-1	9021	113	OFFICIAL	B+S	1910	6	200	131	"	A.C.&F	1913						
2502		"	"	"	"	A-2	A-1	114	"	PULL	1882	7	201	"	"	"	"						
2503		"	"	"	"	A-3	587	115	"	B+S	1906												
2504		"	"	"	"	A-5	585	116	"	"	"												
2505		"	"	"	"	A-7	B-2	117	"	"	1911												
2506		"	"	"	"	A-8	1107	118	"	"	1909												
2507		"	"	"	"	A-10	9006	119	"	PULL	1905												
2508		"	"	"	"	A-18	A-30	120	"	AC+FCo	1900												
2509		"	"	"	"	A-20	A-28	121	"	G.N.RY	1912												
2510		"	"	"	"	A-22		122	"	"	1905												
2511		"	"	"	"	A-23		123	"	B+S.	1882												
2512		"	"	"	"	A-25	903	124	"	"	1883												
2513		"	"	"	"	A-28	A-30	125	"	"	1911												
2514		"	"	"	"	A-30	9016	126	"	"	1911												
2515		"	"	"	"																		
2516		"	"	"	"	99	S.RS.	127	OFFICIAL	B+S.	1883												
2517		"	"	"	"	B-1	7573	128	A.B. INSTRUCH	"	1905												
2518		"	"	"	"																		
2519		"	"	"	"																		
2520		"	"	"	"																		
2521		"	"	"	"																		

B-25-41 5-26-43 5-14-45

5-26-43  
REV. 5-1-24. REV. 8-10-25. REV. 3-1-26. REV. 5-22-28. REV. 6-1-30. REV. 4-26-33. REV. 3-16-39.

BUILT BY HASKELL AND BARKER, 1882.

YEAR	CAR No
1882	185
1883	343
1888	37
1901	402
1908	1208
1908	2183
1924	ST. P. & P. No 1

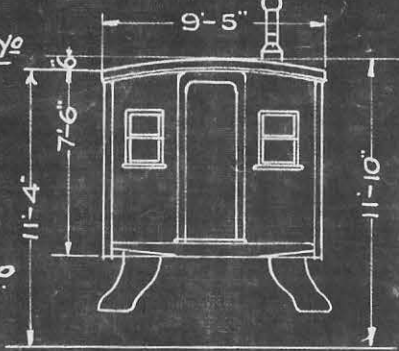

ST. P. & P. CAR No 1.

PASSENGER & BAGGAGE CAR,  
No 2183

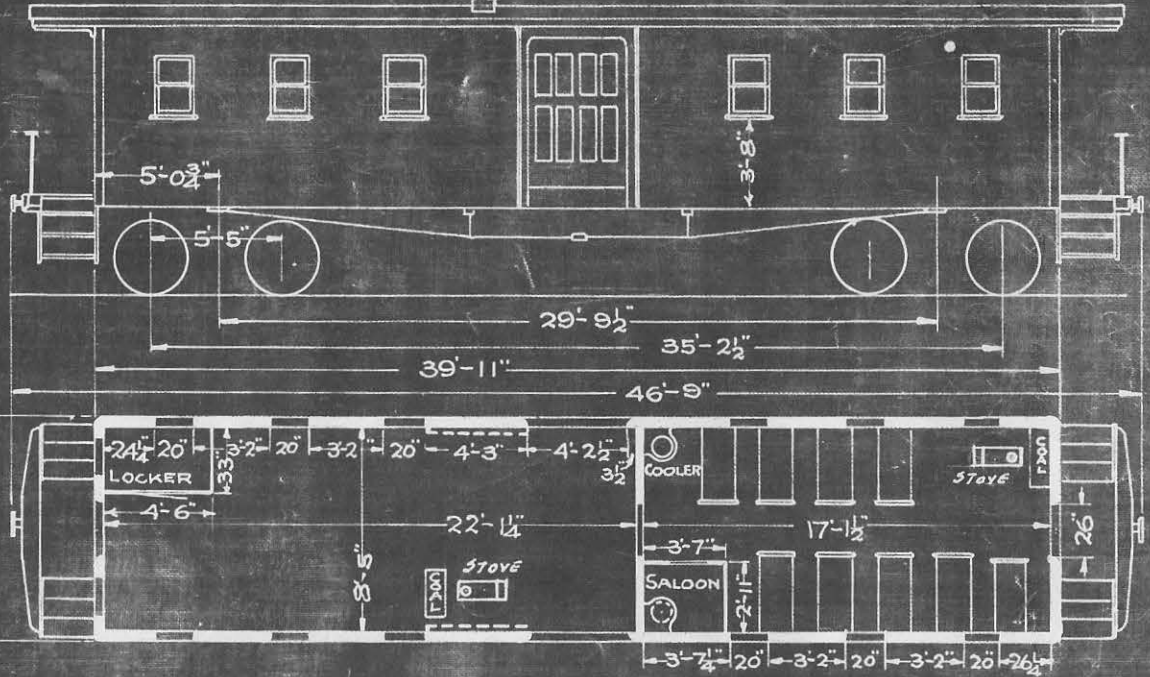

NOTE:-

THIS CAR NOW STENCILED ST. P. & P. No 1.  
USED FOR HISTORICAL PURPOSES.

2183 FORMERLY 2102.

WEIGHT, LBS.-	41,100	TRANSOM CENTERS,	29'- 9 1/2"	AIR BRAKE, (MAKER) WESTINGHOUSE CO.	FINISH, EXTERIOR- BEADED SHEATHING.
LENGTH OVER FRAMING,	39'- 11"	TOTAL WHEEL BASE,	35'- 2 1/2"	BRAKE CYLINDER	8" DIA. x 12"
LENGTH OVER BUFFERS,	46'- 9"	TRUCK WHEEL BASE,	5'- 5"	HEATER,	DAVIS STOVES TWO.
WIDTH OVER FRAMING,	9'- 0"	WHEELS,- STEEL TIRED	DIA. 33		
WIDTH OVER CROWN MLDG.	9'- 5"	NUMBER OF WHEELS,- EIGHT.			
SEATING CAPACITY,	18	JOURNALS, SIZE,-	4 1/2" x 8"		
CAPACITY LBS	20000				
				WATER SYSTEM	1 COOLER.
					COUPLERS
					LINK & PIN.
					FINISH, INTERIOR- PASS.- BEADED SHEATHING.
					BAGG.- " " " "
					PASS.- " " " "
					BAGG.- " " " "
					HEAD LINING- CANDLE LAMPS.
					LIGHTING-
					LAMPS,- PASS.- 2- 1LT. SIDE; SALOON, 1- 1LT. SIDE.
					BAGG.- 3- 1LT. SIDE.



XL

PASSENGER CAR  
ST. P. & P. No 3

YEAR	CAR No
1882	407
1882	38
1901	410
1908	2123
1924	St. P. & P. No 3

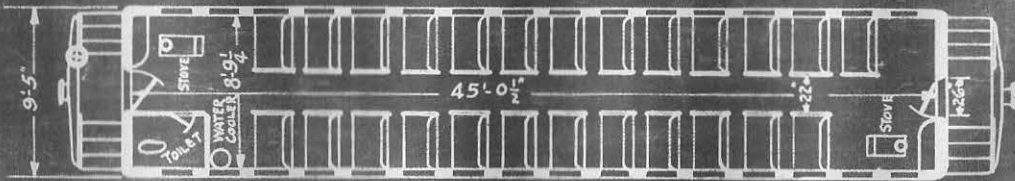
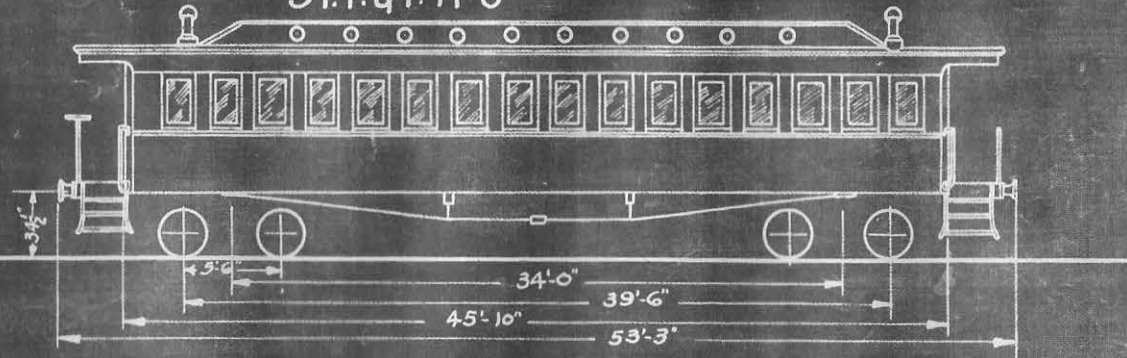
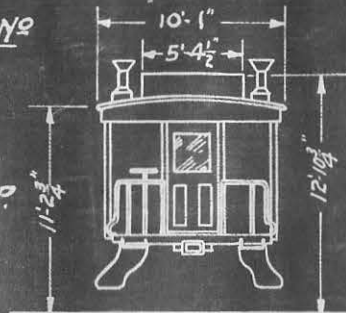

NOTE:-

THIS CAR NOW STENCILED ST. P. & P. No 3 USED FOR HISTORICAL PURPOSES

9-6-27. REV. 6-1-30. REV. 4-26-33. REV. 3-16-39. 5-26-43

WEIGHT-LBS.	46100
LENGTH INSIDE	45'-0 1/2"
WIDTH "	8'-9 3/4"
LENGTH OVER BUFFERS	53'-3"
" " FRAMING	45'-10"
SEATING CAPACITY	50 PASSENGERS

TRUCK CENTER	34'-0"
TRUCK WHEELBASE	5'-6"
WHEEL BASE TOTAL	39'-6"
JOURNALS SIZE	4 1/4" x 8"
WHEELS	STEEL TIRED 33"

AIR BRAKE	NEW YORK
CYLINDER	8"
HEATER	DAVIS STOVES 2

FINISH, EXTERIOR	PANELS.
" INTERIOR	PAINTED
HEAD LINING	CANVAS
LIGHTING	CANDLE LAMP.
LAMPS	PASS. 10-1LT. SIDE TOILET 1-1LT. SIDE
COUPLER	LINK & PIN.

CAR Nos	BUILDER	YEAR
23 36	P.S.C.Co.	1918

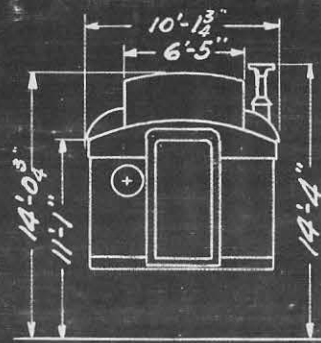

### 60 FT. MAIL CAR (STEEL)

1.

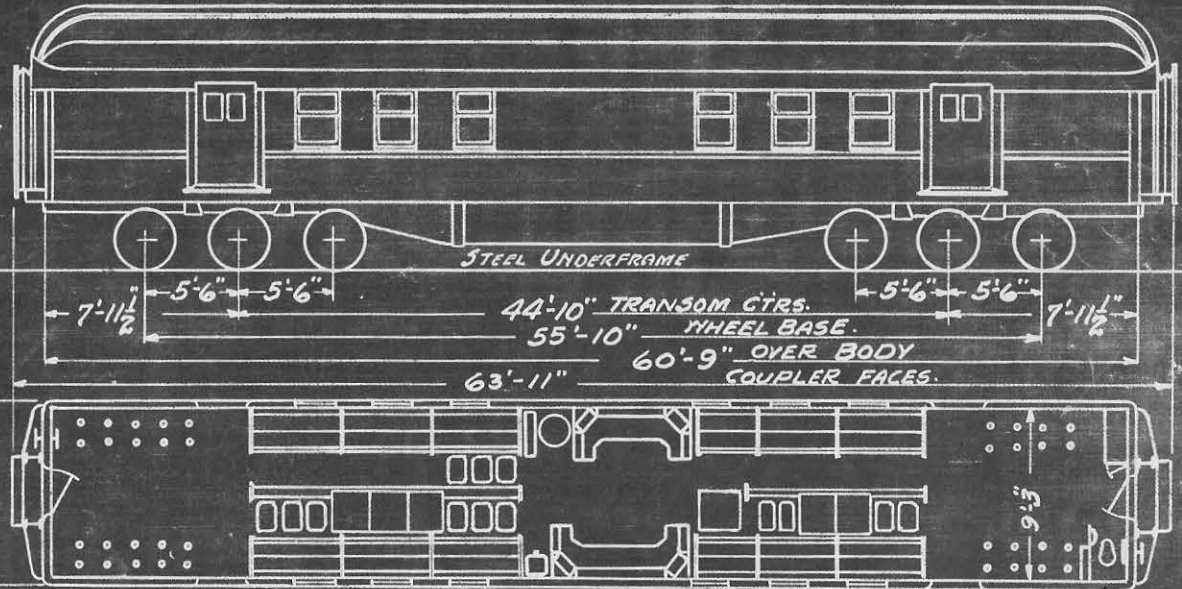

+ MINER DRAFT GEAR-SWIVEL BUTT COUPLER 5"x7"  
25, 26, 29, 31, 32, 33, 34.

1-CEILING & 2 BRKT. FANS.

1ST AID KIT.

M.A.

WEIGHT-LBS. 142700 #	TRANSOM CENTERS - 44'-10"	AIR BRAKE - CYLINDER 18"x12"	OUTSIDE FINISH - STEEL.
LENGTH OVER BODY - 60'-9"	TOTAL WHEEL BASE - 55'-10"	AIR SIGNAL -	INSIDE FINISH - STEEL.
LENGTH, COUPLER FACES - 63'-11"	TRUCK WHEEL BASE - 11'-0"	HEATING - VAPOR.	AXLE LIGHT SYSTEM - 3 K.W.
WIDTH OVER BODY - 9'-11"	WHEELS, ROLLED STEEL - 36 1/2"-DIA.	HEATER - DOUBLE COIL.	BODY BOLSTER - STR. STEEL.
WIDTH OVER CROWN MLDG. 10'-1 3/4"	CLASP BRAKE - AMERICAN.	LIGHTING - ELECTRIC.	DRAFT GEAR <sup>+</sup> - FARLOY.
TRUCKS - CAST STEEL.	JOURNAL SIZE - 5"x9"	LAMPS - 18	COUPLER <sup>+</sup> - SHORT SHANK. 6 1/2" BUTT.

REV. 5-8-41 12-15-41 5-26-43  
REV 12-15-24. REV. 3-1-26. REV. 3-1-26. REV. 10-12-27 REV. 6-1-30. REV. 9-12-32.

BUILT BY B. & S. C. Co. - 1914  
REBUILT BY G. N. RY. 1927

# 60 FT. BAGGAGE & MAIL CARS Nos 44 TO 47

2.

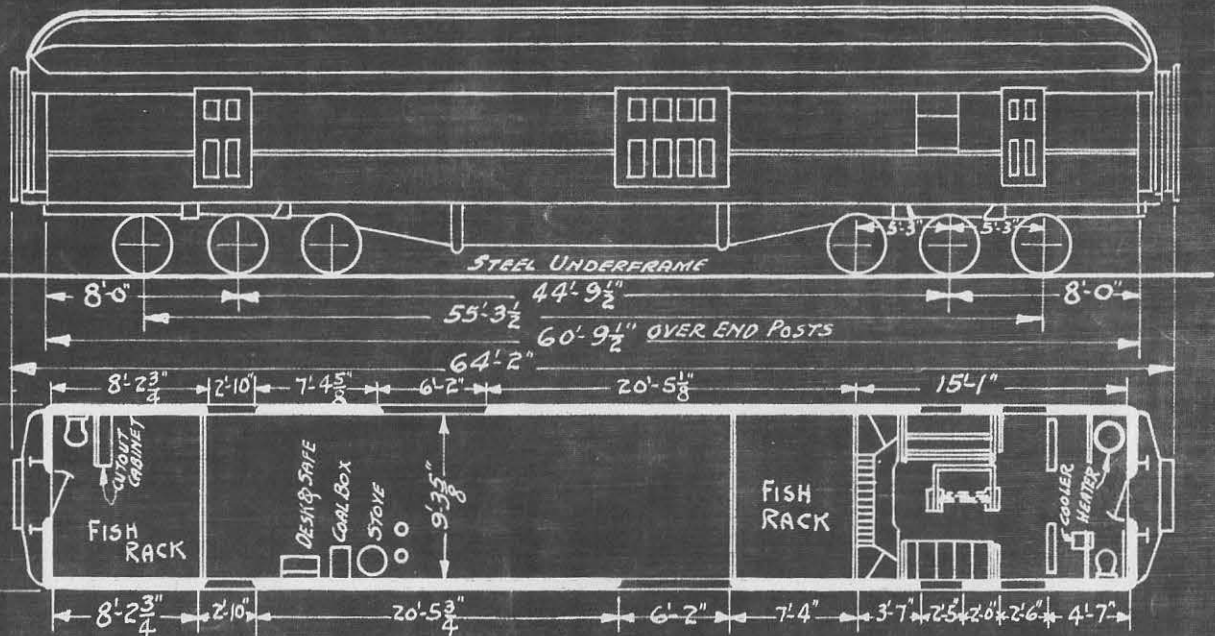
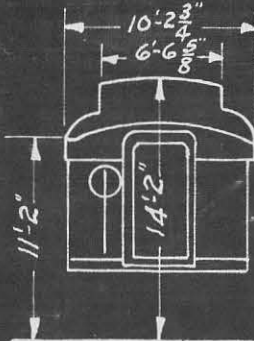

X MINOR FRICTION DRAFT GEAR, 5" x 7"  
TYPE "E" SWIVEL BUTT COUPLER  
45,

BAKER HEATER MOVED FROM MAIL TO  
BAGG. END ON 45.

A.F.E 34977  
FORMERLY BAGGAGE CARS Nos 222 TO 225

MB

3-1-28, REV. 6-1-30, REV. 9-12-32, 5-26-43

WEIGHT	135500 LBS.	TRUCK CENTERS	44'-9 1/2"	AIR BRAKE	CYLINDER 18" x 12"	OUTSIDE FINISH	SHEET STEEL
LENGTH OVER FRAMING	60'-9 1/2"	TOTAL WHEEL BASE	55'-3 1/2"	AIR SIGNAL		INSIDE	" " " "
" " BUFFERS	64'-2"	TRUCK	10'-6"	HEATING	VAPOR & BAKER	BODY BOLSTER	BUILT UP
WIDTH " FRAMING	10'-0"	WHEELS, ROLLED STEEL	36 1/2"	HEATER	1-BAKER HEATER & H.W. STOVE	DRAFT GEAR	X FARLOW
" " CROWN MILDG.	10'-2 3/4"	JOURNAL SIZE	5" x 9"	LIGHTING	AXLE GEN. - ELECTRIC	COUPLER	X SHORT SHANK, 6 1/2" BUTT.
TRUCK	CAST STEEL				ONE BRACKET FAN. ONE 1ST AID KIT.		



BUILT BY B. & S. C. Co. - 1914  
 REBUILT BY G. N. RY. 1927

# 60 FT. BAGGAGE & MAIL CARS NOS 48, 49

3

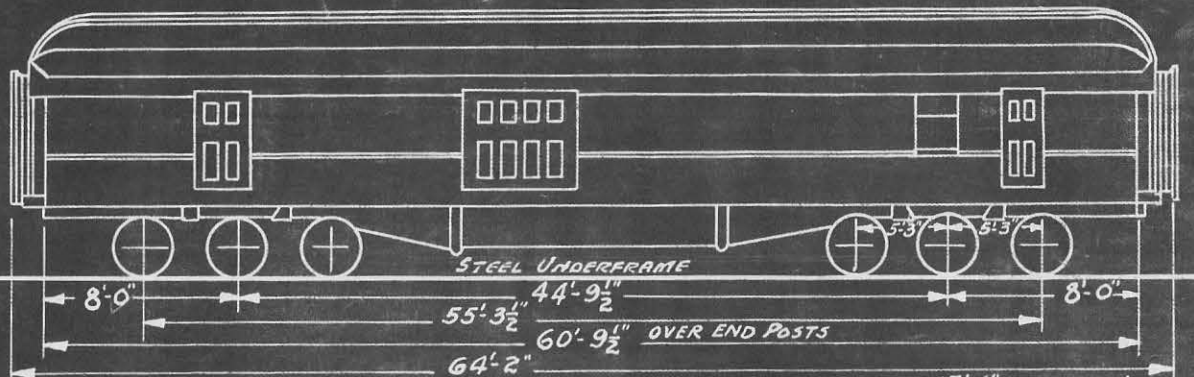
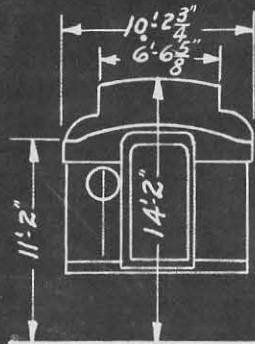

CAR NO 48 HAS TRUCKS FROM A-18  
 " 49 " " " A-20.

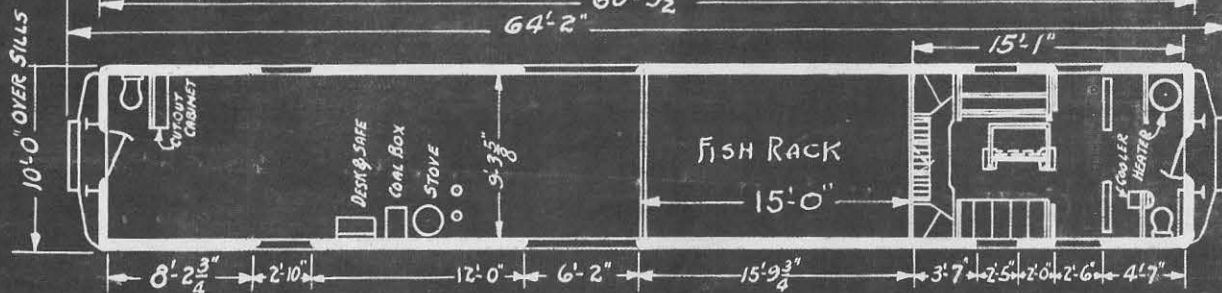

A.F.E 34977  
 FORMERLY BAGGAGE CARS NOS 232, 234

MB

9-1-27 Rev. 3-1-28 Rev. 6-1-30 Rev. 9-12-32 5-26-43

WEIGHT	140300 LBS.	TRUCK CENTERS	44'-9 1/2"	AIR BRAKE	CYLINDER 18"X12"	OUTSIDE FINISH	SHEET STEEL
LENGTH OVER FRAMING	60'-9 1/2"	TOTAL WHEEL BASE	55'-3 1/2"	AIR SIGNAL		INSIDE	" " "
" " BUFFERS	64'-2"	TRUCK " "	10'-6"	HEATING	VAPOR & BAKER	BODY BOLSTER	BUILT UP
WIDTH " FRAMING	10'-0"	WHEELS, ROLLED STEEL	36 1/2"	HEATER	1-BAKER HEATER & 1-N.W. STOVE	DRAFT GEAR	FARLOW
" " CROWN MLDG.	10'-2 3/4"	JOURNAL SIZE	5'x9"	LIGHTING	AXLE GEN. - ELECTRIC	COUPLER	SHORT SHANK, 6 1/2" BUTT.
TRUCK	CAST STEEL			ONE BRACKET FAN			
				" 1 1/2" AID KIT			

BUILT BY B. & S. C. Co. 1914.  
REBUILT BY G. N. Ry. 1924.

# BAGGAGE MAIL & EXPRESS CAR Nos 50, 51.

4.

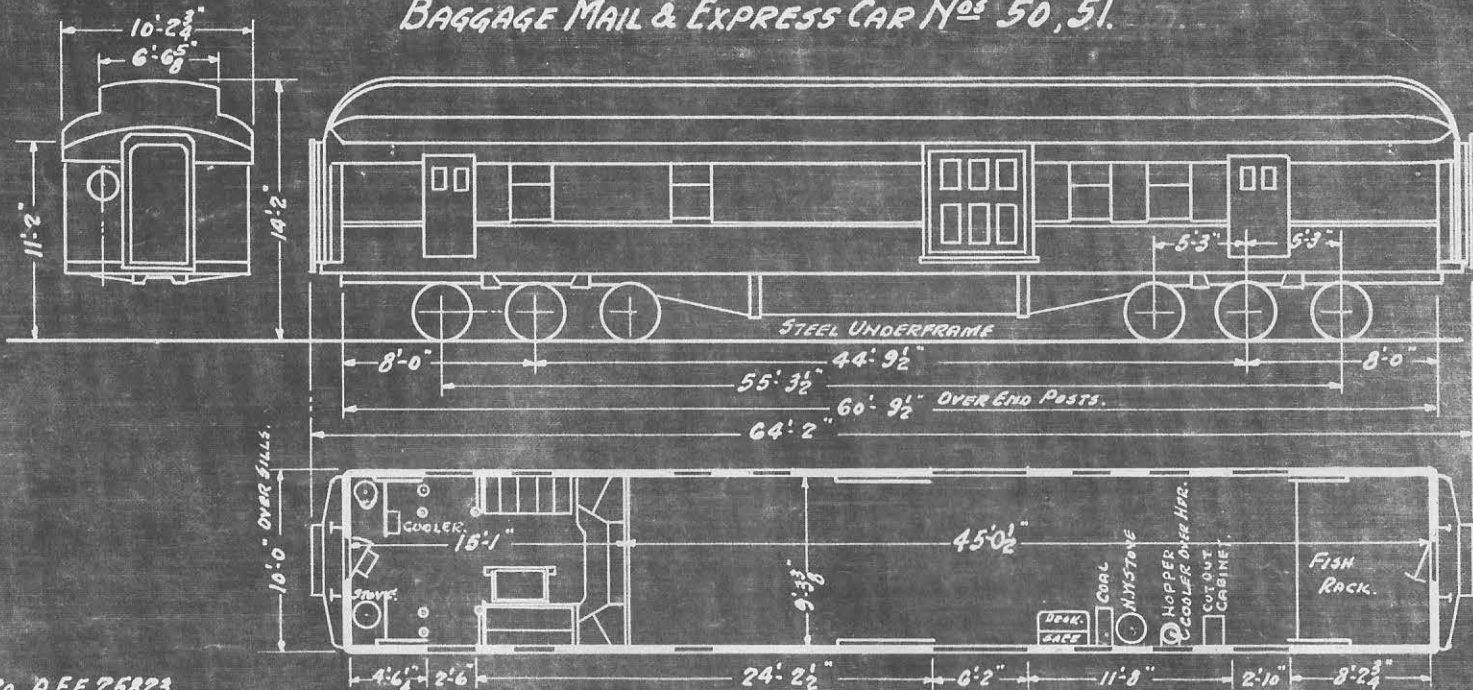

FORMERLY MAIL CAR Nos 19 & 20. A.F.E 25823.

WEIGHT	134100 LBS.	TRUCK CENTERS	44'-9 1/2"	AIR BRAKE	1-18" x 12" CYL.	FINISH, EXTERIOR	SHEET STEEL
LENGTH OVER FRAMING	60'-9 1/2"	WHEELBASE - TRUCKS	10'-6"	" SIGNAL		" INTERIOR	"
" " BUFFERS	64'-2"	" " TOTAL	55'-3 1/2"	HEAT	DIRECT STEAM.	LIGHTING	AXLE GEN. ELECTRIC.
WIDTH " FRAMING	10'-0"	WHEELS STEEL Tired	36 1/2" DIA.	BODY BOLSTER	BUILT UP.	DRAFT GEAR	FARLOW
" " CROWN MLDG.	10'-2 3/4"	JOURNALS, SIZE	5" x 9"	HEAT PIPING	2 1/2" 276 FT.	COUPLER	SHORT SHANK - 6 1/2" BUTT.
		KIND OF TRUCKS	CAST STEEL.	ONE BRACKET FAN.			
				ONE 1 <sup>ST</sup> AID KIT.			

5-1-24. REV. 12-15-24. REF. 6-1-25. REV. 3-1-26. REV. G-1-30. REF. 9-12-32. 5-26-43

12-15-44, 5-26-43  
 Rev. 5-1-24, Rev. 6-1-25, Rev. 3-1-26, Rev. 6-1-30, Rev. 6-8-31, Rev. 12-19-31, Rev. 5-2-41

CAR Nos	BUILDER	YEAR
52 TO 71	A.C. & F.D.	1918.

## 70 FT. BAGGAGE MAIL & EXPRESS CAR. (ALL STEEL.)

5

† CAR 54 & 71 - MINER DRAFT GEAR  
 AND SWIVEL BUTT COUPLER, 5x7  
 ALSO 56, 52, 57, 64, 56, 71,  
 60.  
 Δ WESTG. SE. FRICTION DRAFT  
 GEAR, 5x7 TYPE "E" SWIVEL  
 BUTT COUPLER.  
 53, 62, 68.

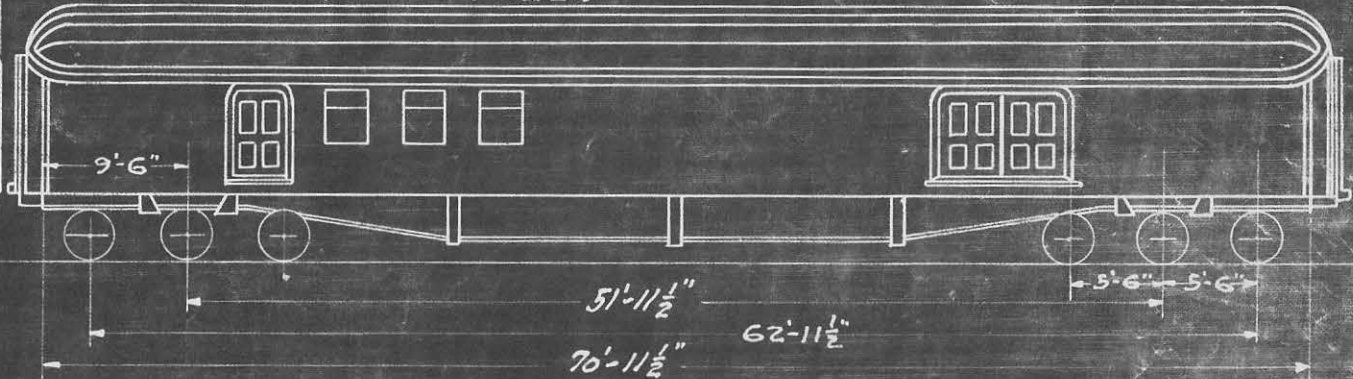

57 }  
 CAR 55 } EQUIPPED WITH  
 MINER VERTICAL WHEEL  
 POWER HAND BRAKE.

53 EQUIPPED WITH PEACOCK  
 POWER HAND BRAKE.

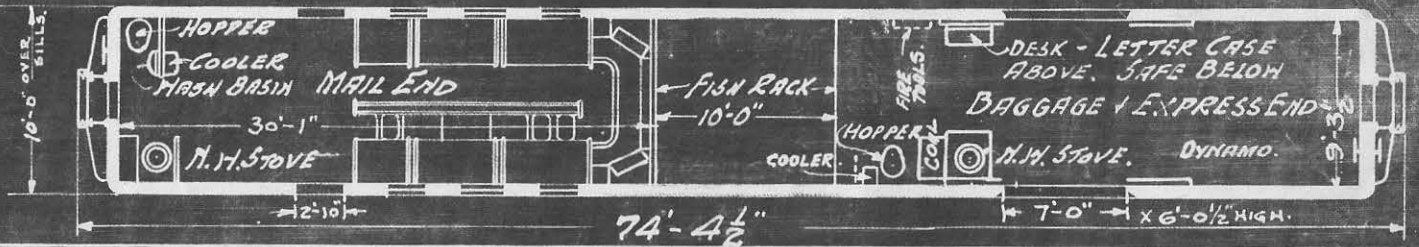

HEIGHT, LBS. 14500  
 LENGTH OVER FRAMING 70'-11 1/2"  
 " " BUFFERS 74'-4 1/2"  
 WIDTH • FRAMING 10'-0"  
 " " CROWN MLDG. 10'-2 3/4"  
 TRUCKS, CAST STEEL.

TRANSOM CENTERS 51'-11 1/2"  
 TOTAL WHEEL BASE 62'-11 1/2"  
 TRUCK " " 11'-0"  
 WHEELS 36" DIA.  
 TWO BRACKET FANS  
 ONE FIRST AID KIT  
 JOURNALS SIZE 5"x9"

AIR BRAKE. 1-18x12 CYL.  
 AIR SIGNAL.  
 HEATER, NORTHWESTERN.  
 HEATING, CHICAGO VAPOR SYSTEM.  
 2" PIPE 440 FT.  
 CAPACITY LBS. = 50000.  
 CLASP BRAKE - AMER. BRAKE CO.

OUTSIDE FINISH, STEEL.  
 INSIDE FINISH, STEEL.  
 LIGHTING, AXLE GEN. ELECTRIC  
 LAMPS, 16 - 40 WATT - 65 VOLTS.  
 DRAFT RIGGING † FARLOWY.  
 COUPLER † SHORT SHANK 6 1/2" BUTT.

MB



REV. 6-8-30. REV. 12-18-31. REV. 3-17-37. REV. 5-2-41. 12-15-44. 5-26-43  
 REV. 5-1-24. REV. 12-15-24. REV. 3-1-26. REV. 3-1-28. REV. 5-6-29. REV. 1-29-30. REV. 6-1-30.

CAR NOS	BUILDER	YEAR
72 To 93	AC&FCo	1913

CAR No 73-STEEL SHEATHED 1926.  
 WT. 132800 LBS.  
 † CAR 90 & 92-MINER DRAFT  
 GEAR & SWIVEL BUTT COUPLER.  
 ALSO 91, 83, 86, 87  
 WEST SE GEAR, 5'x7" TYPE E  
 SWIVEL BUTT CPLR.  
 72, 93,

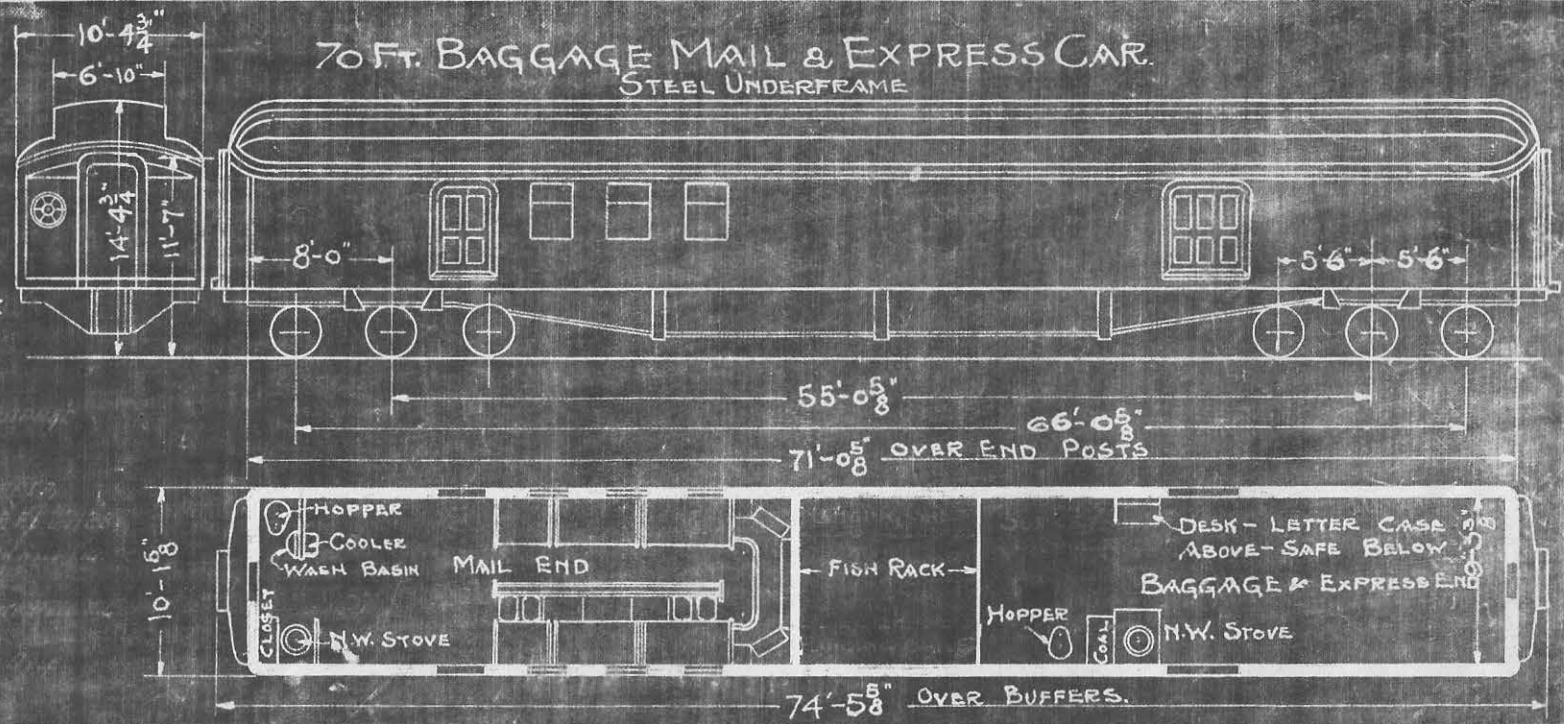

6.

WEIGHT, LBS.	129400 LBS.
LENGTH OVER FRAMING	71'-0 5/8"
LENGTH " BUFFERS	74'-5 3/8"
WIDTH OVER FRAMING	10'-0"
WIDTH " CROWN	10'-4 3/4"
TRUCKS,	CAST STEEL

TRANSOM CENTERS,	55'-0 5/8"
TOTAL WHEEL BASE,	66'-0 5/8"
TRUCK " "	11'-0"
WHEELS, STEEL TIRE	36 1/2"
TWO BRACKET FANS.	
JOURNALS SIZE	5x9"

AIR BRAKE, 18x12" CYL.  
 AIR SIGNAL, "  
 HEATER, N.Y. STOVE  
 HEATING, GOLD SYSTEM, DIRECT  
 CAPACITY LBS. = 50000.  
 ROLLER BEARING-HYATT CAR No 92,  
 ONE FIRST AID KIT.

OUTSIDE FINISH, GR. SHEATHING  
 INSIDE FINISH, GR. LINING  
 LIGHTING, ELECTRIC  
 LAMPS, ME. 9EL - BE 9EL  
 DRAFT RIGGING<sup>†</sup> FARLOW  
 COUPLER<sup>†</sup> SHORT SHANK 6 1/2" BUTT.

MB

# MAIL & BAGGAGE CAR Nos 100 to 105

7.

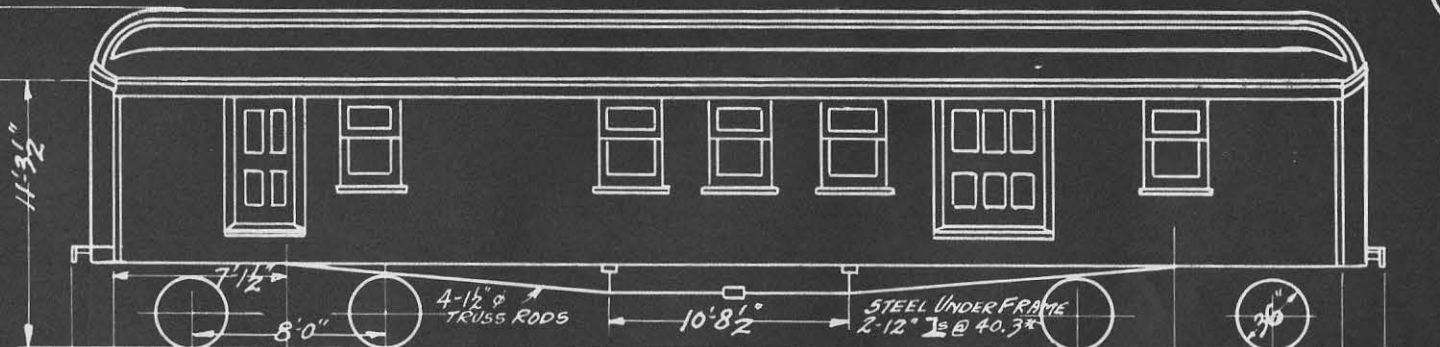
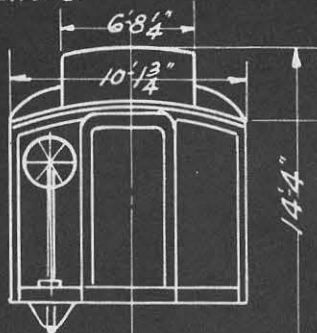

100	FORMERLY 173
101	" 174
102	" 175
103	" 176
104	" 178
105	" 180

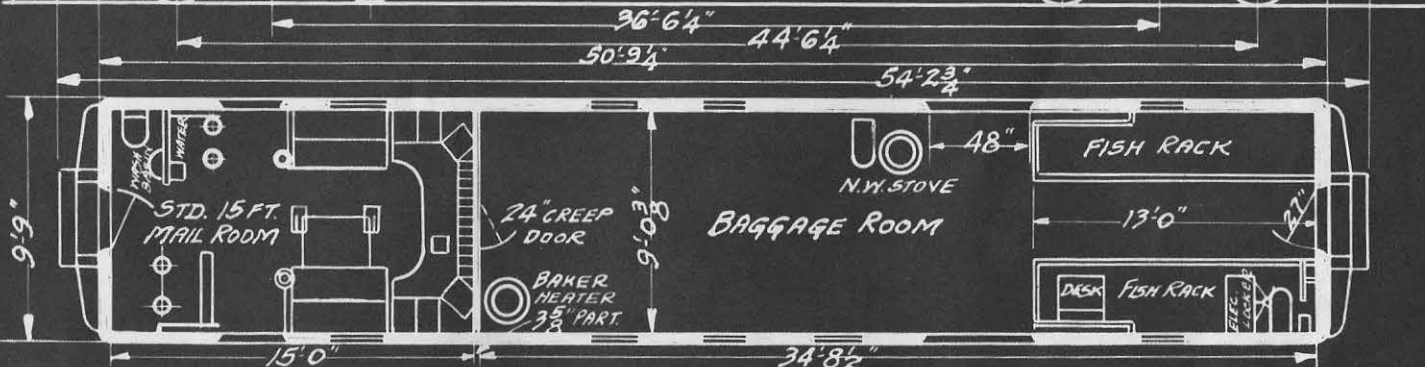

R.F.E. 65757 - STEEL UNDERFRAME.

WEIGHT	89600 LBS.
LENGTH OVER FRAMING	50'9 1/4"
" " BUFFERS	54'2 3/4"
WIDTH OVER FRAMING	9'9"
" " CROWN MOULD	10'1 3/4"

BOLSTER CENTERS	36'6 1/4"
JOURNALS	5'9"
KIND OF TRUCK	METAL FACED.
WHEELS	36" STEEL.

AIR BRAKE	1-14" x 12" CYL.
AIR SIGNAL	" " " "
METALLIC STEAM CONNECTORS	" " " "
OUTSIDE FINISH	WOOD SHEATHING
INSIDE " " " "	" " " "

DRAFT GEAR	MINER A2 x B
COUPLER	SWIVEL BUTT 5' x 7"
LIGHTING	ELECTRIC
COUPLER CENTERING DEVICE	" " " "
HEATER PIPES	12" x 2"

4-15-43, 5-26-43

MB

BUILT BY BARNEY & SMITH 1898.

# BAGGAGE MAIL & EXPRESS CAR Nos 106, 107

8

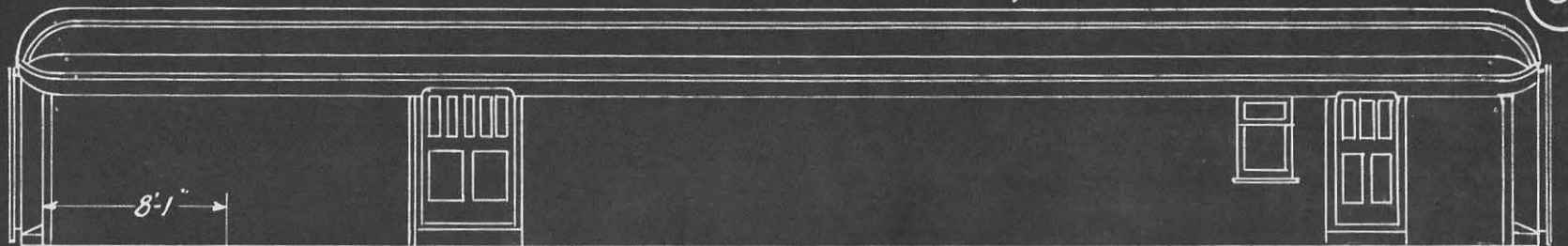
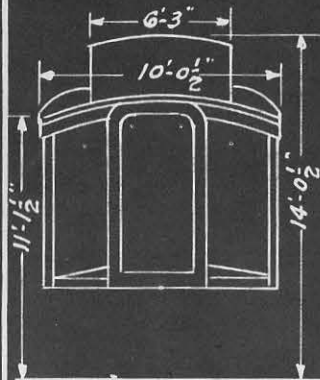

STEEL CENTER SILLS.

106 FORMERLY 153  
107 " 154.

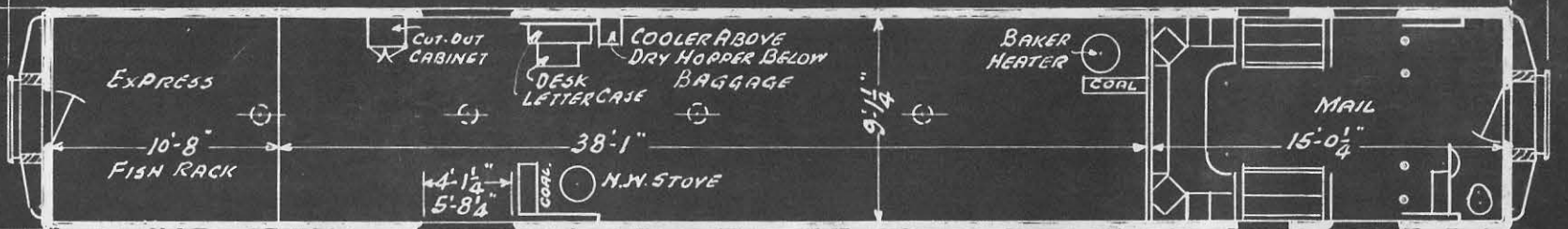
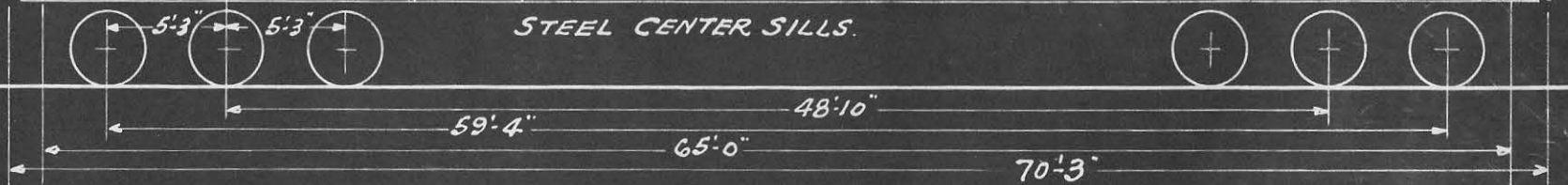

RFE 65757

MB

WEIGHT	112000 LBS.	TRUCK CENTERS	48'-10"	AIR BRAKE	1-10"x12" CYL.	FINISH, EXTERIOR	GROOVED SHEATH'G.
LENGTH OVER FRAMING	65'-0"	WHEEL BASE-TRUCK	10'-6"	BAKER HEATER	DUPLEX COIL.	FINISH, INTERIOR	BEADED "
LENGTH OVER BUFFER	70'-3"	" - TOTAL	59'-4"	NORTH WESTERN STOVE.		HEAD LINING	BEADED CEILING
WIDTH OVER FRAMING	9'-8"	WHEELS - ROLLED STEEL	36" DIA.	DIRECT STEAM.		LIGHTING	AYLE GEN. - ELECTRIC.
WIDTH OVER CROWN MLDG.	10'-0 1/2"	KIND OF TRUCK	METAL FACED.	1 FIRST AID KIT.		DRAFT GEAR	FRICTION.
CAPACITY	40000 LBS.	JOURNALS - SIZE	5" x 9"	1-BRACKET FAN		COUPLER	5"x7" TYPE "E" SWIVEL BUTT.

118-33. 12-15-41 5-26-43



BUILT BY BARNEY & SMITH 1898

BAGGAGE, MAIL & EXPRESS CARS Nos 155, 108, 109

9

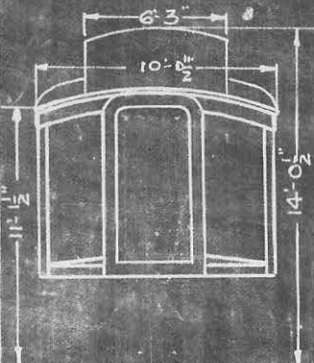

STEEL CENTER SILLS

108 FORMERLY 155  
109 " 157

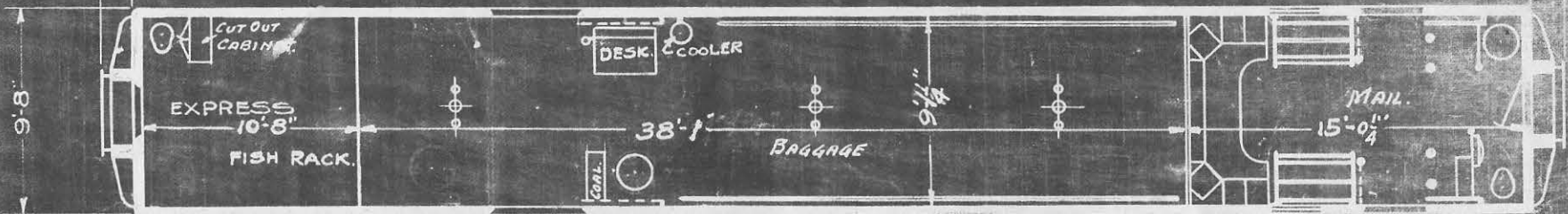

AFF 65757

WEIGHT, LBS.	110800
LENGTH OVER FRAMING,	65'-0"
LENGTH OVER BUFFERS,	70'-3"
WIDTH OVER FRAMING,	9'-8"
WIDTH OVER CROWN MLDG.	10'-0 1/2"
CAPACITY LBS	40000

TRANSOM CENTERS,	48'-10"
TOTAL WHEEL BASE,	59'-4"
TRUCK WHEEL BASE,	10'-6"
WHEELS, STEEL,	DIA. 36"
KIND OF TRUCK	METAL FACED
JOURNALS, SIZE,	5" X 9"

AIR BRAKE,	1-10" X 12" CYL.
AIR SIGNAL,	
HEATER, BAKER	
DIRECT STEAM.	
HEATER PIPING,	-2- 255 FT.
1 BRACKET FAN	
1 FIRST AID KIT	

FINISH, EXTERIOR,	GROOVED SHEATHING.
FINISH, INTERIOR,	BEADED SHEATHING.
HEAD LINING,	BEADED CEILING.
LIGHTING,	AXLE GEN. ELECTRIC.
DRAFT GEAR	FRICTION
COUPLER	5" X 7" TYPE 'E' SWIVEL BOT.

MB

CAR No. 61570, 618, 610 TO 614.  
 REV. 5-1-24. CAR 613 DESTROYED. REV. 11-8-37. 5-26-43  
 CHANGED FROM 108 TO 155. DIMENSIONS. SEE LISTING. REV. 1-2-51. REV. 6-1-25. REV. 3-1-26. REV. 6-1-30.

BAGG. MAIL & EXPRESS CAR Nos 110 to 117 10.

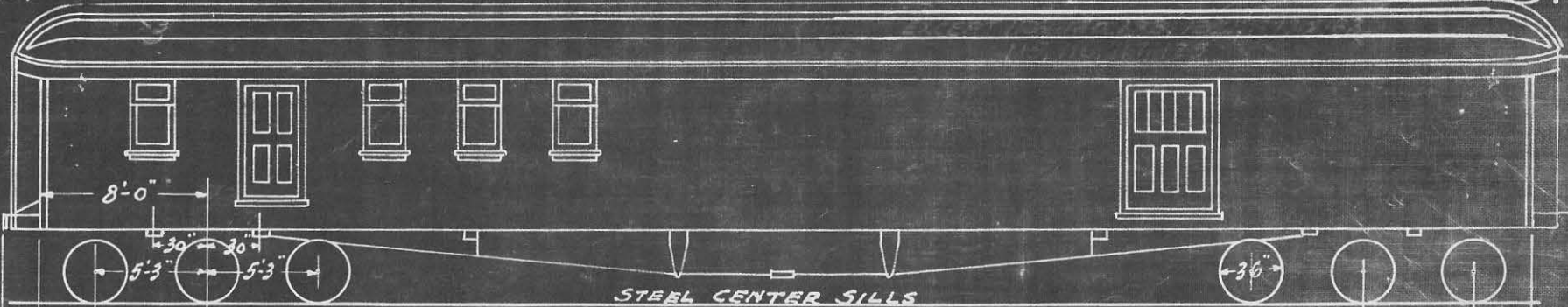
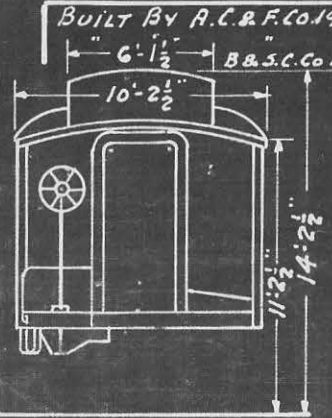

- 111 To 110
- 112 To 111
- 114 " 112
- 118 " 113
- 131 " 114
- 135 " 115
- 136 " 116
- 137 " 117

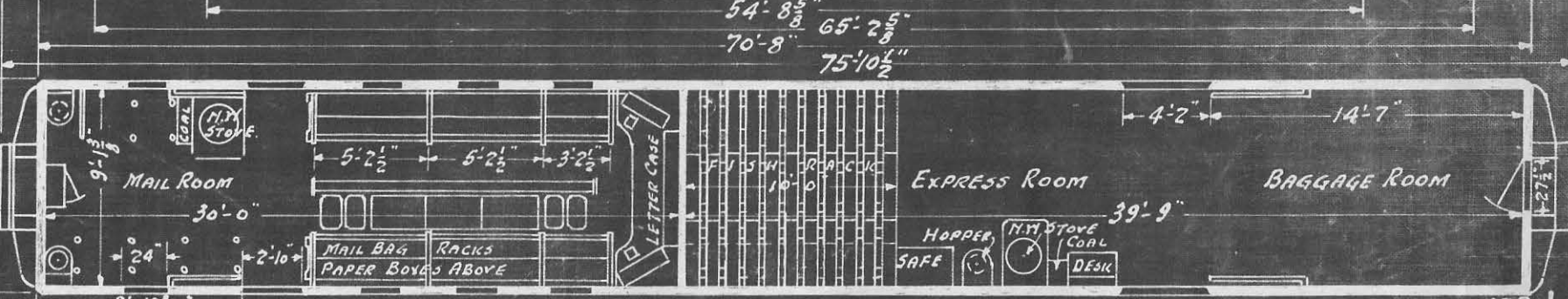

5-26-23  
 REV. 9-5-36 REV. 6-8-31 REV. 12-18-31  
 3-1-26 REV. 9-15-27 REV. 2-9-28 REV. 3-1-28

AFE 6575T

WEIGHT	116400 LBS.
LENGTH OVER FRAMING	70'-8"
" " BUFFERS	75'-10 1/2"
WIDTH " FRAMING	9'-10"
" " CROWN MOLD'G.	10'-2 1/2"
CAPACITY	50000 LBS.

TRUCK CENTERS	54'-8 5/8"
TOTAL WHEEL BASE	65'-2 5/8"
TRUCK " "	10'-6"
WHEELS	STEEL 36" DIA
TRUCK	METAL FACED
JOURNALS	SIZE 5 x 9"

AIR BRAKE	1-16" x 12" CYL.
" SIGNAL	"
HEATER	TYNO-N.Y. STOVES
GOLD'S SYSTEM DIRECT STEAM HEAT	
HEATER PIPING	2" 297 FT.
2-BRACKET FANS	

FINISH-EXTERIOR	GROOVED SHEATHING
" " INTERIOR	BEADED LINING
LIGHTING	OIL & ELECTRIC. X
DRAFT GEAR	FRICTION.
COUPLER	5'x7" TYPE 'E' SWIVEL BUTT.
OIL & GAS ON CAR No 110 to 113.	X
AXLE GENERATOR CAR No 114 to 117	X

BUILT BY A.C.&F.CO. 1904.  
STEEL UNDERFRAME APPLIED 1925.

# BAGG. MAIL & EXPRESS CAR No 148 & 149.

11.

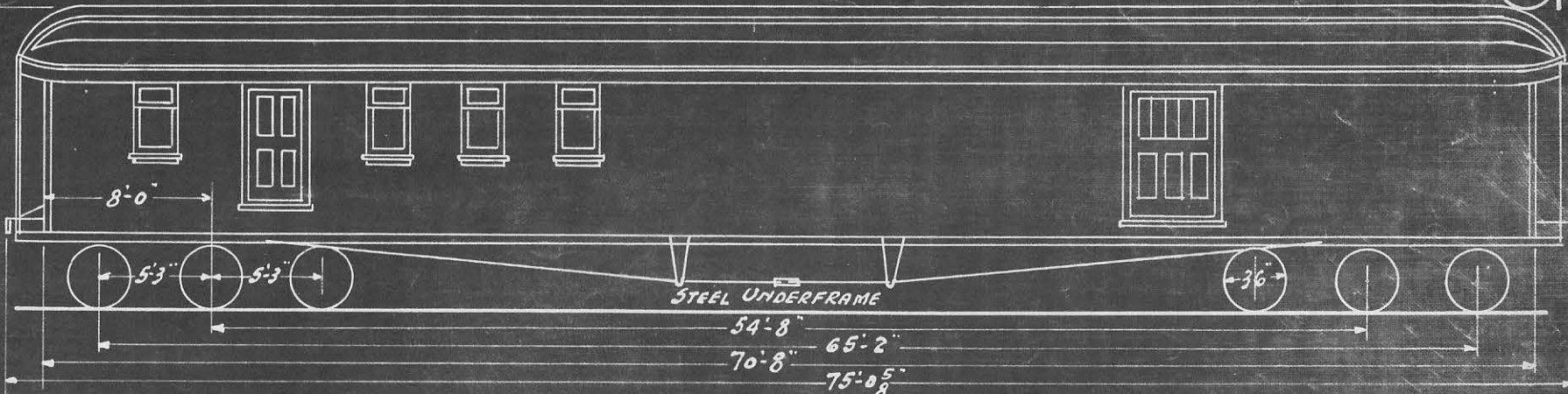
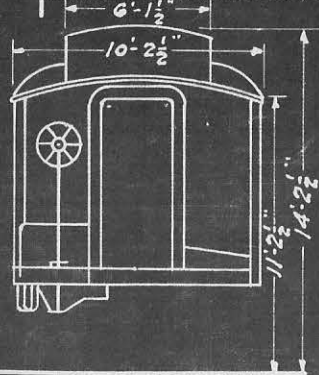

148 FORMERLY 102  
149 " 103

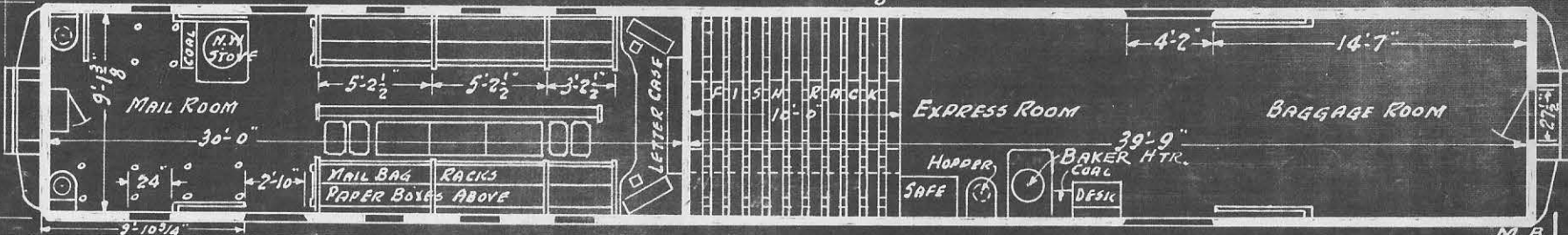

A.F.E. 19149

REV. 12-18-31. REV. 5-2-41 5-26-43  
3-1-26. REV. 3-1-28. REV. 6-1-30. REV. 6-8-31.

WEIGHT	133 000 LBS.	TRUCK CENTERS	54'-8"	AIR BRAKE	L-18x12" CYL.	FINISH - EXTERIOR	GROOVED SHEATHING.
LENGTH OVER FRAMING	70'-8"	TOTAL WHEEL BASE	65'-2"	" SIGNAL		" - INTERIOR	BEADED LINING
" " BUFFERS	75'-0 5/8"	TRUCK " "	10'-6"	HEATER	BAKER HTR & 1 N.Y. STOVES	LIGHTING	AWL GEN. ELECTRIC.
WIDTH	9'-10"	WHEELS	STEEL 36" DIA.	GOLD'S SYSTEM DIRECT STEAM HEAT		DRAFT GEAR	MINER A-5-P-X.
" " CROWN MOLDG.	10'-2 1/2"	TRUCK	METAL FACED	HEATER PIPING	2" 297 FT.	COUPLER	SHORT SHANK 9/8" BUTT.
CAPACITY	50000 LBS.	JOURNALS	SIZE 5x9"	TWO BRACKET FANS		" SWIVEL BUTT	CAR 148

149



BUILT BY B. & S. 1898.

# BAGGAGE, MAIL & EXPRESS CAR No 150, 151.

12

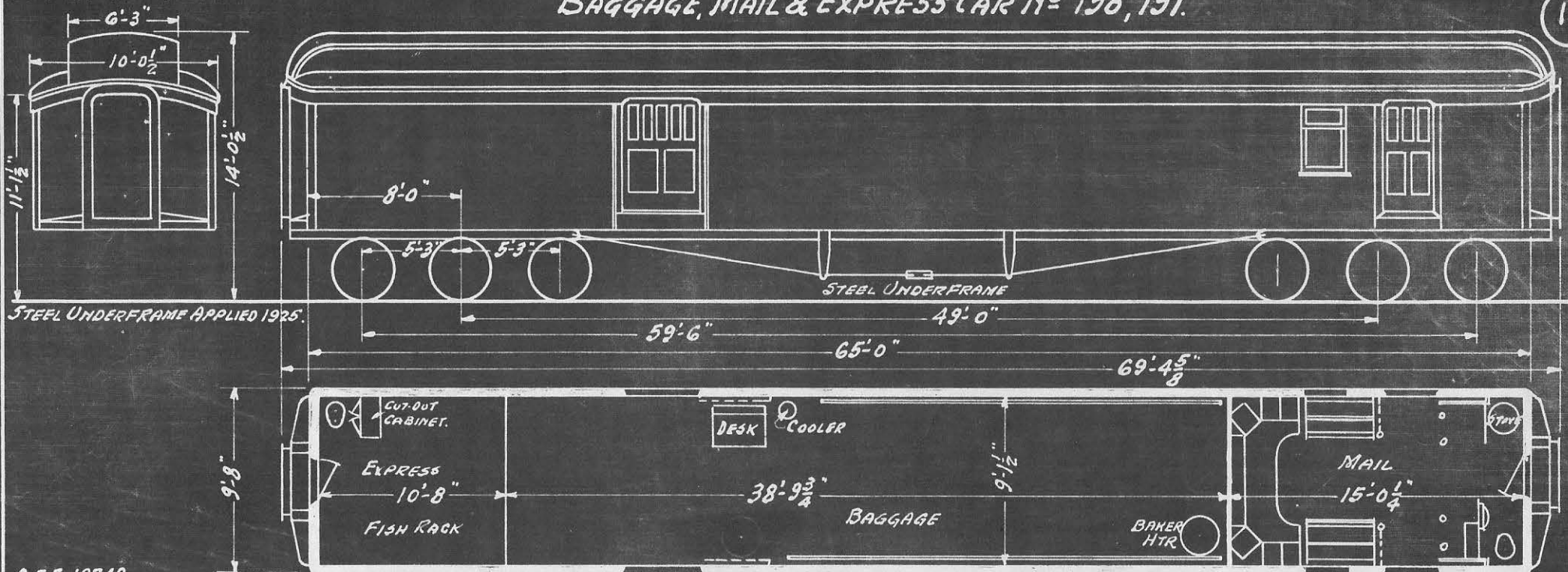

A.F.E. 19749.

WEIGHT	124800 LBS.	TRUCK CENTERS	49'-0"	AIR BRAKE	16" x 12" CYL.	NEW YORK	FINISH, EXTERIOR	GROOVED SNEATH'G.
LENGTH OVER FRAMING	65'-0"	WHEEL BASE TOTAL	59'-6"	AIR SIGNAL	" "	" "	" INTERIOR	BEADED "
" " BUFFERS	69'-4 5/8"	" " TRUCK	10'-6"	HEATER	1 N.Y. STOVES & DIRECT STEAM'G.	" "	HEAD LINING	" "
WIDTH " FRAMING	9'-8"	WHEELS - STEEL	1 - 36 1/2" DIA.	HEATER PIPING	2" DIA.	255 FT.	LIGHTING	AXLE GEN. - ELECTRIC.
" " CROWN MLDG.	10'-0 1/2"	JOURNALS - SIZE	5" x 9"	1-BRACKET FAN			DRAFT GEAR	MINER A-5-P-X.
CAPACITY	40000 LBS.	KIND OF TRUCK	METAL FACED				COUPLER	SHORT SHANK - 9 1/8" BUTT.

G-1-25. REV. 3-1-26. REV. 6-1-30. 5-2-6-43

MB

BUILT BY B. & S. C. Co. - 1914  
REBUILT BY G. N. RY. - 1927

# 60 FT. BAGGAGE & MAIL CARS Nos 181 to 185, 188 to 192

13.

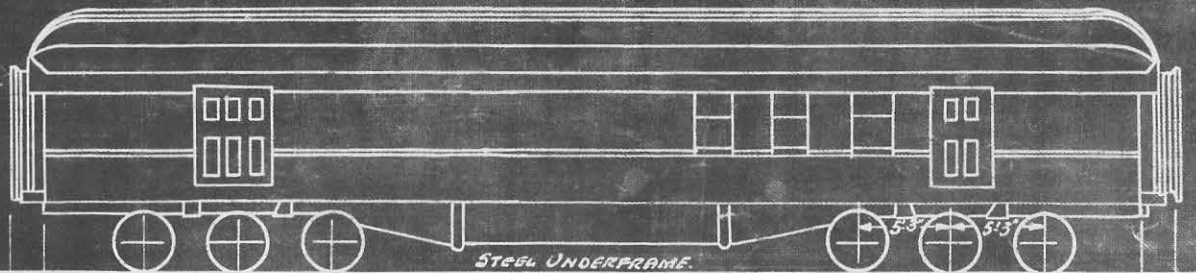
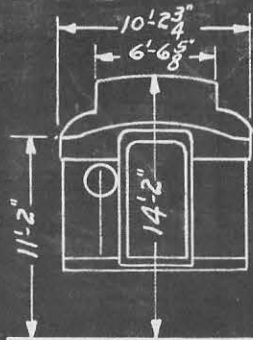

BAKER HTR MOVED FROM MAIL TO BAGG. END ON CAR 189.

CAR No 188 HAS TRUCK FROM A-22  
+ CAR 192 - MINER DRAFT GEAR AND SWIVEL BUTT COUPLER, 5X7 TYPE E. 189, 192,

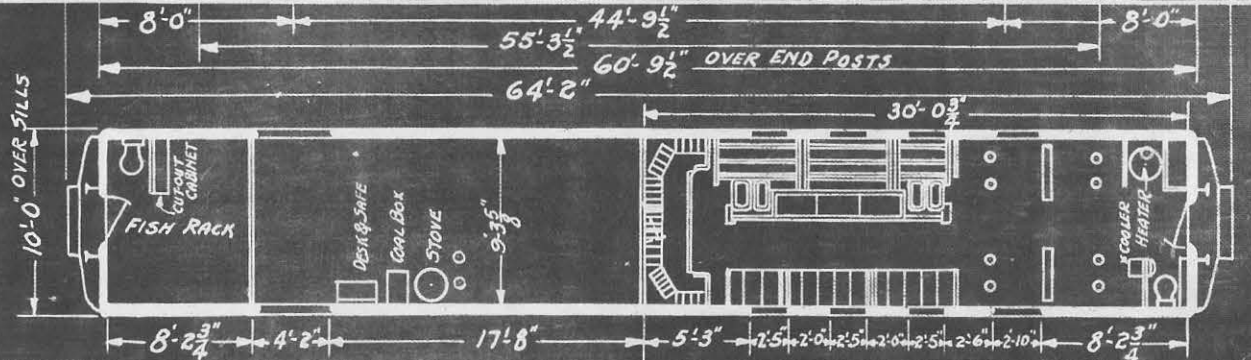

A.F.E. 34411, 34977  
FORMERLY BAGGAGE CARS Nos

MB

WEIGHT LBS	135800
LENGTH OVER FRAMING	60'-9 1/2"
" " BUFFERS	64'-2"
WIDTH " FRAMING	10'-0"
" " CROWN MLDG	10'-2 3/4"
TRUCK	CAST STEEL

TRUCK CENTERS	44'-9 1/2"
TOTAL WHEEL BASE	55'-3 1/2"
TRUCK " "	10'-6"
WHEELS, ROLLED STEEL	36 1/2"
JOURNAL SIZE	5" x 9"

AIR BRAKE	CYLINDER 18" x 12"
AIR SIGNAL	
HEATING	VAPOR & BAKER HEATER
HEATER	1 - BAKER HEATER & 1 - M.W. STOVE
LIGHTING	AXLE GEN. ELECTRIC
TWO BRACKET FANS.	

OUTSIDE FINISH	SHEET STEEL
INSIDE " "	" "
BODY BOLSTER	BUILT UP
DRAFT GEAR	FARLOW
COUPLER	SHORT SHANK 6 1/2" BUTT.

5-1-27, REV. 8-10-28, REV. 6-1-30, REV. 9-12-32, REV. 5-2-41, 5-26-43

11-22-39 5-26-43  
 OLD NOS. 60 64, Rev. 3-1-26, Rev. 6-1-30, Rev. 12-18-31, Rev. 9-9-35.

BUILT BY AM. CAR & FDY. CO 1904.  
 REARRANGED AT G. N. SHOPS 1916.

MAIL STORAGE CAR NOS 206

14.

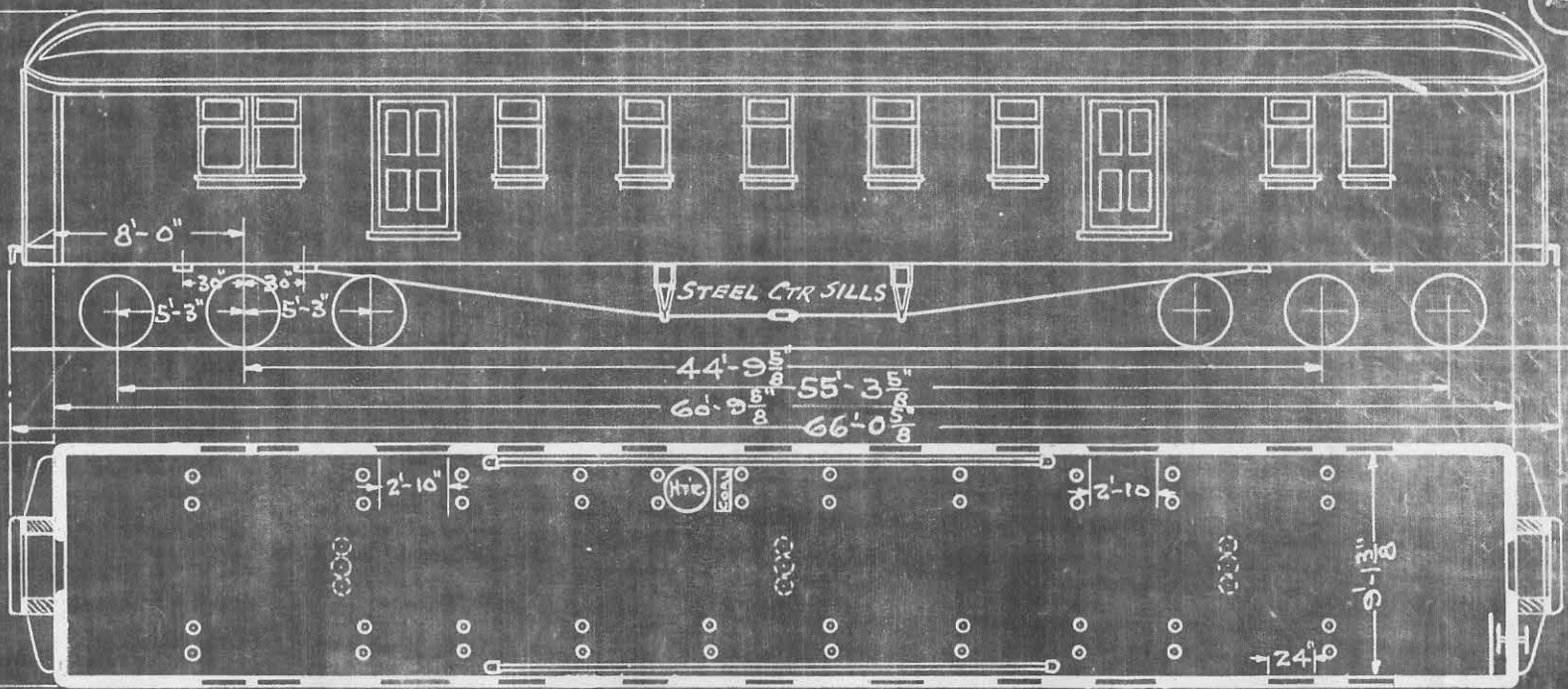
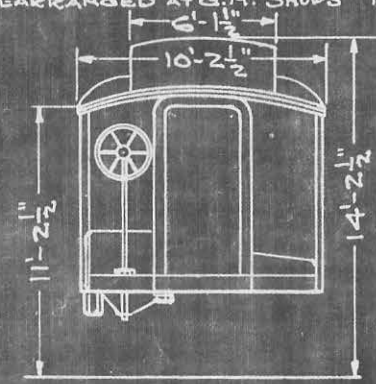

FORMERLY 249  
 RETIRED 11-1-26

206 FORMERLY 249

RFE 65757

MR

WEIGHT, LBS. - 102000 LBS.  
 LENGTH OVER FRAMING, - 60'-9 <sup>5</sup>/<sub>8</sub>"  
 LENGTH OVER BUFFERS, - 66'-0 <sup>5</sup>/<sub>8</sub>"  
 WIDTH OVER FRAMING, - 9'-10"  
 WIDTH OVER CROWN MLDG. 10'-2 <sup>1</sup>/<sub>2</sub>"

TRANSOM CENTERS, - 44'-9 <sup>5</sup>/<sub>8</sub>"  
 TOTAL WHEEL BASE, - 55'-3 <sup>5</sup>/<sub>8</sub>"  
 TRUCK WHEEL BASE, - 10'-6"  
 WHEELS, - STEEL, 36" DIAM.  
 KIND OF TRUCK - METAL FACED  
 JOURNALS, - SIZE, 5" x 9"

AIRBRAKE - 1-14" x 12" CYL.  
 AIR SIGNAL  
 HEATER, - N.W. DOUBLE COIL  
 HEATING, - GOULD SYSTEM COMB.  
 HEATER PIPING, - 2"

OUTSIDE FINISH; GROOVED SHEATHING  
 INSIDE FINISH, - BEADED LINING  
 LIGHTING, - OIL  
 LAMPS, - 3-2 LIGHT CENTER  
 DRAFT GEAR - FRICTION  
 COUPLER - 5x7 TYPE E SWIV. BUTT.



REV. 3-17-39. 11-24-31. 5-26-43  
 REV. 5-1-24. REV. 3-1-26. REV. 6-1-30. REV. 12-18-31. REV. 9-30-33. REV. 4-9-35. REV. 9-9-35.

BUILT BY B&S CAR CO 1911

MAIL STORAGE CAR Nos. 207

15

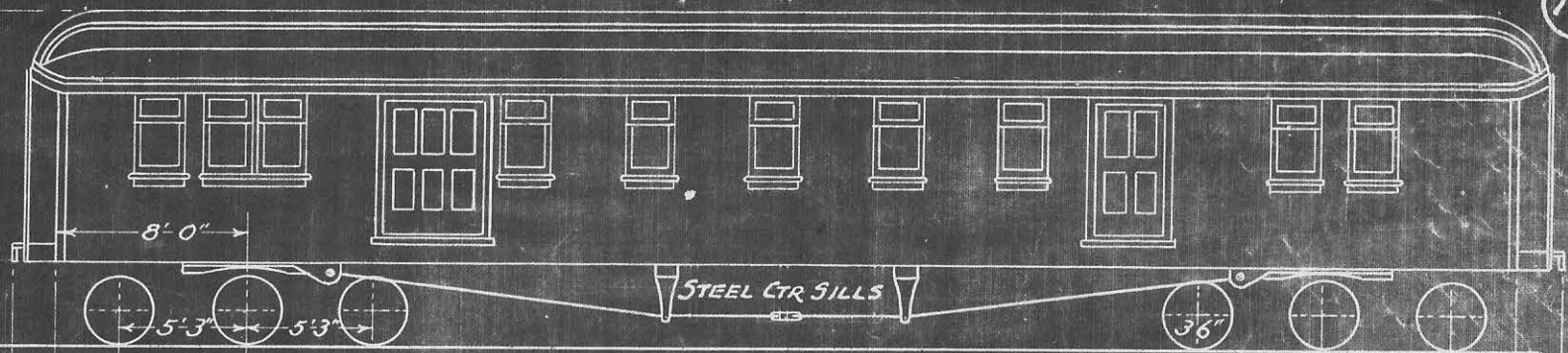
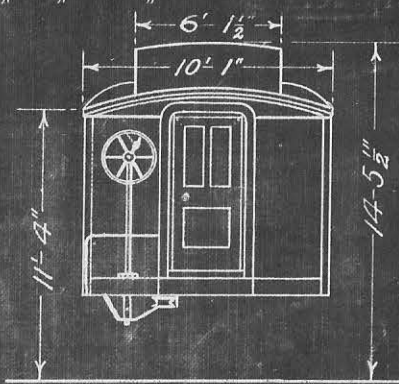

207 FORMERLY 262

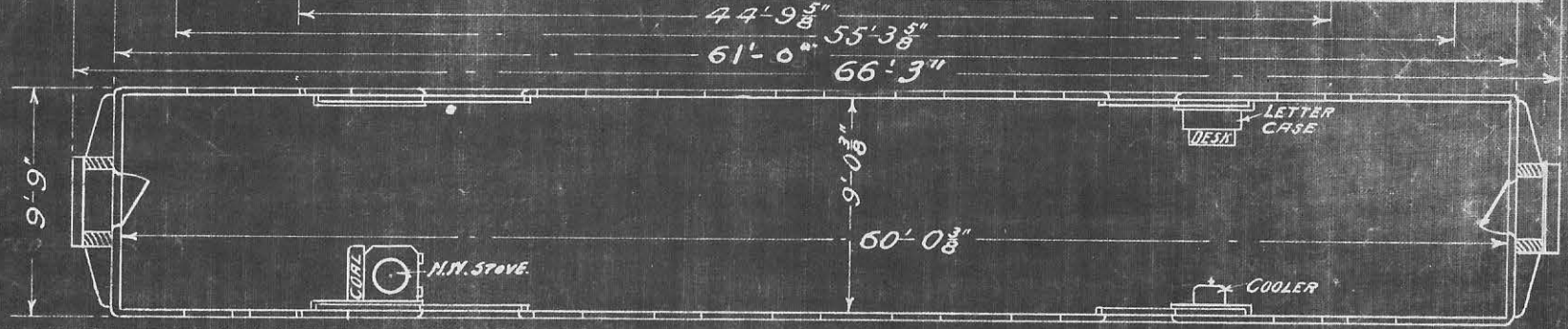

AFE 65757

WEIGHT	107300 LBS.	BOLSTER CENTERS	44'-9 <sup>5</sup> / <sub>8</sub> "	AIR BRAKE -	1-14" x 12 CYL.	AIR BRAKE CYLINDER	12" x 16"
LENGTH OVER FRAMING	61'-0"	TRUCK WHEEL BASE	10'-6"	AIR SIGNALS -		TWO MILLER FIRE EXTINGUISHERS	
" " BUFFERS	66'-3"	TOTAL " "	55'-3 <sup>5</sup> / <sub>8</sub> "	HEATING -		OUTSIDE FINISH -	GROOVED SHEATHING
WIDTH " FRAMING	9'-9"	STEEL " 36" DIAM.		DRAFT GEAR		INSIDE " "	BEADED LINING
" " DECK	6'-1 <sup>1</sup> / <sub>2</sub> "	KIND OF TRUCK	METAL FACED			LIGHTING -	4 No. 76 OIL LAMPS
" " CROWN MOULD.	10'-1"	JOURNALS	5" x 9"	COUPLER	5 x 7" TYPE "E" SWIV. BUTT.	" "	14-15 EL. WALL "

REV. 3-17-39, 11-22-39, 5-26-43  
 OLD NOS. 550 TO 556, 559, REV. 5-1-24, REV. 3-1-26, REV. 6-1-30, REV. 9-9-35.

BUILT BY BARNEY & SMITH 1896

# BAGGAGE & EXPRESS CAR No. 208

16

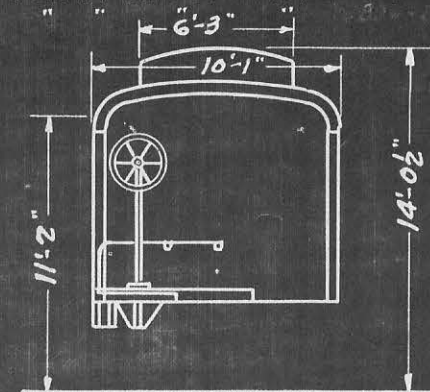

208 FORMERLY 268

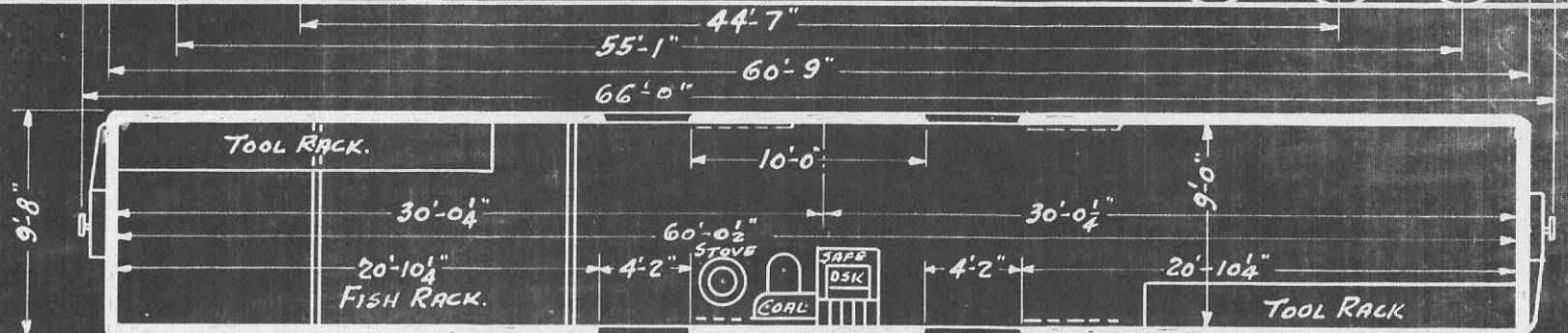
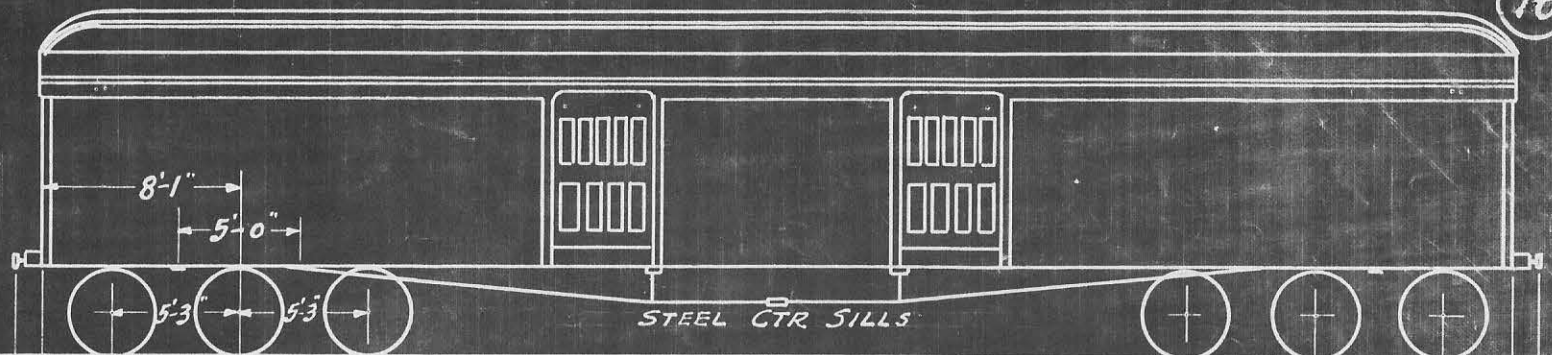

A.F.E. 66757

WEIGHT	87000 LBS	TRUCK CENTERS	44'-7"	AIR BRAKE	1-10x12" CYL.	FINISH EXTERIOR	GROOVED SHEATHING.
LENGTH OVER FRAMING	60'-9"	TOTAL WHEEL BASE	55'-1"	AIR SIGNAL	"	" INTERIOR	BEADED "
" " BUFFERS	66'-0"	TRUCK " "	10'-6"	HEATER, DIRECT STEAM & N-N STOVE	"	HEAD LINING	" CEILING
WIDTH OVER FRAMING	9'-8"	WHEELS ROLLED STEEL DIAM.	36"	HEATER PIPING	1 1/4" 242 FEET.	LIGHTING	" OIL.
" " CROWN MLD'G.	10'-1"	KIND OF TRUCK	METAL FACED.			DRAFT GEAR	" FRICTION
CAPACITY	40,000 LBS.	JOURNALS SIZE	5x9"			COUPLER	5x7" "E" SWIV. BUTT.

BUILT BY A.C. & F. CO. 1905

BAGGAGE & EXPRESS CAR NOS 209, 210

17

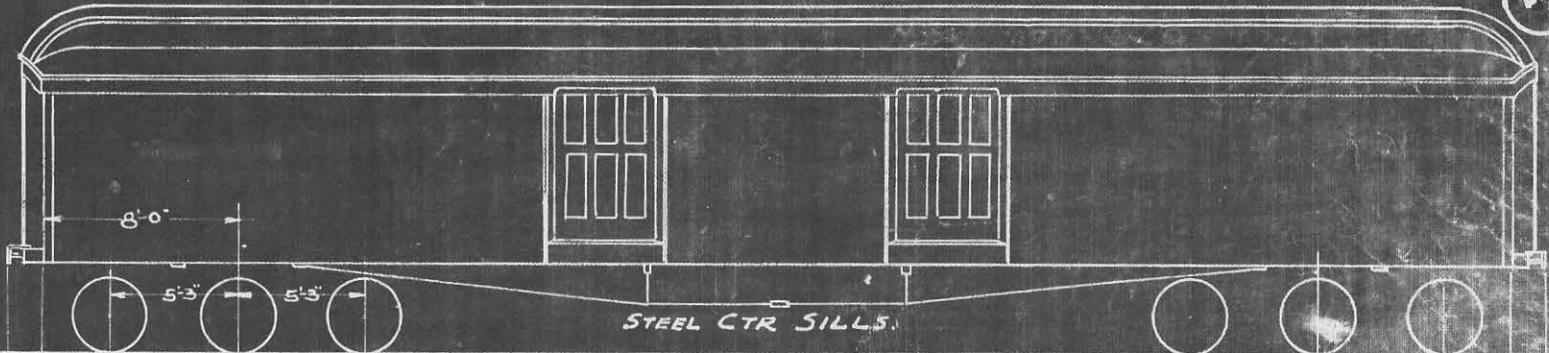
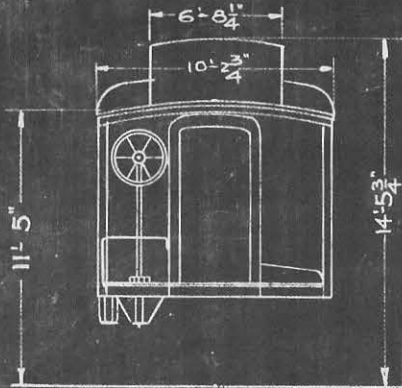

209 FORMERLY 275  
210 " 278

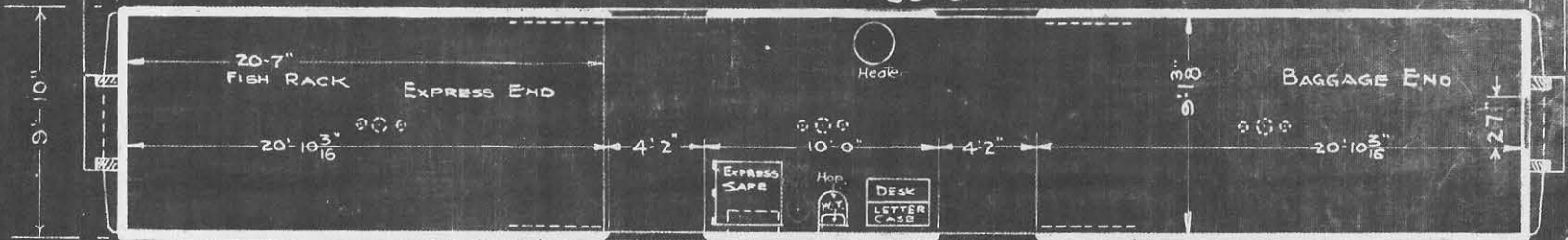

AFC 65757

BE

5-26-43 REV. 5-1-24. REV. 3-1-26. REV. 6-1-30. REV. 6-8-30. REV. 12-18-31. REV. 3-17-39.

WEIGHT, LBS.	97,500	TRANSOM CENTERS,	44'-9"	AIR BRAKE,	1-14x12" CYL.	FINISH, EXTERIOR, GROOVED SHEATHING.
LENGTH OVER FRAMING,	60'-9"	TOTAL WHEEL BASE,	55'-3"	AIR SIGNAL,		FINISH, INTERIOR, BEADED LINING.
LENGTH OVER BUFFERS,	66'-0"	TRUCK WHEEL BASE,	10'-6"	HEATER, (MAKER)	N:W. STOVE WITH DIRECT STEAM	HEAD LINING, BEADED LINING.
WIDTH OVER FRAMING,	9'-10"	WHEELS, STEEL, DIAM!	36"	HEATER PIPING,	2'- 250 FT.	LIGHTING, ELEC. & OIL.
WIDTH OVER CROWN M'LD'G,	10'-2 3/4"	KIND OF TRUCK	METAL FACED			DRAFT GEAR FRICTION
CAPACITY LBS	40000	JOURNALS, SIZE.	5" x 9"			COUPLER 5'x7" "E" SWIV. BUTT.



5-26-43

Rev. 5-1-24. Rev. 3-1-26. Rev. 6-1-30. Rev. 12-18-31. REV. 3-17-39. 11-22-39. 3-26-40.

BUILT BY BARNEY & SMITH 1905

BAGGAGE & EXPRESS CARS Nos. 211, 212

18

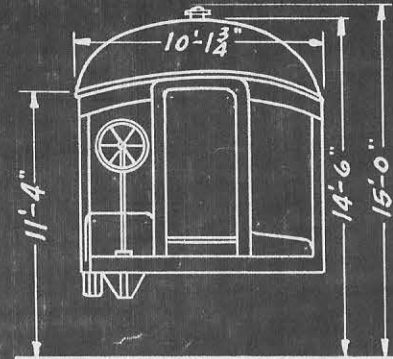

211 FORMERLY 281  
212 " 285

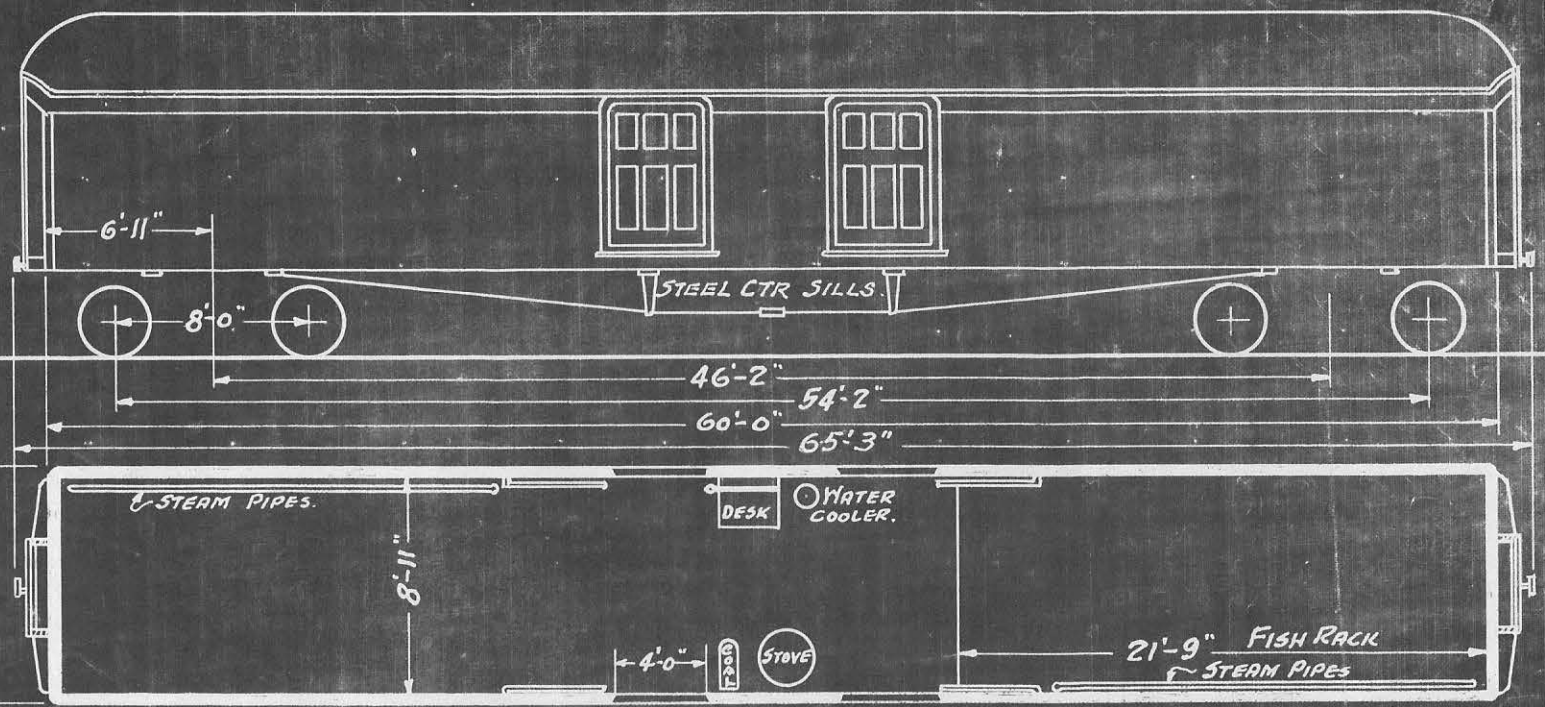

AFE 65757

WEIGHT	89000 LBS.	TRUCK CENTERS	46'-2"	AIR BRAKE	1-14"x12" CYL.	FINISH EXTERIOR	BEADED SHEATHING
LENGTH OVER FRAMING	60'-0"	TOTAL WHEEL BASE	54'-2"	AIR SIGNAL	"	" INTERIOR	"
" " BUFFERS	65'-3"	TRUCK	8'-0"	HEATER	1 N-W. STOVE-STEAM LINE	LIGHTING	OIL FITTED WITH ELECT. TRAIN LINE
WIDTH " FRAMING	9'-9"	WHEELS	STEEL DIAM. 36"	HEATER PIPING	2" FT.	DRAFT GEAR	FRICTION
" " CROWN MLDG.	10'-1 3/4"	KIND OF TRUCK	METAL FACED	HEIGHT OF CAR INSIDE	9'-5 1/4"	COUPLER	5"x7" E" SWIV. BUTT.
HEIGHT " ROOF	14'-6"	JOURNALS	SIZE 5 1/2"x10"	LENGTH	59'-1 3/4"		
" " LAMP JACK	15'-0"	CAP'Y. OF CAR	50000 LBS.	CLEAR HEIGHT TO LAMPS	7'-1"		

BE.

11-22-39, 5-26-43  
 Rev. 5-1-24, Rev. 3-1-26, Rev. 3-1-28, Rev. 6-1-30, Rev. 12-18-31, Rev. 9-9-35, Rev. 3-17-39

BARNEY & SMITH 1893.

BAGGAGE CAR Nos. 213

19.

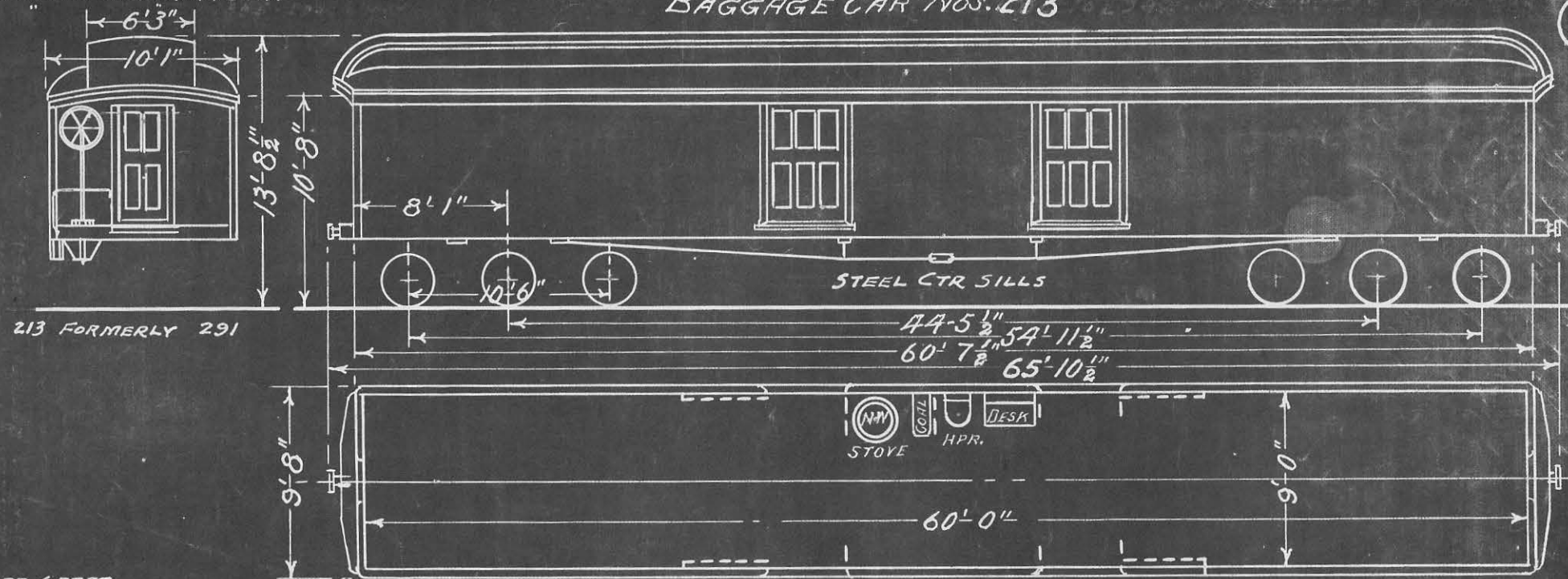

RFE 65757

WEIGHT	88500 LBS.	BOLSTER CENTERS	44'-5 1/2"	AIR BRAKE	1-14" x 12" CYL.	OUTSIDE - GROOVED SHEATHING
LENGTH OVER FRAMING	60'-7 1/2"	TRUCK WHEEL BASE	10'-6"	AIR SIGNAL		INSIDE - BEADED LINING
" " BUFFERS	65'-10 1/2"	TOTAL " "	54'-11 1/2"	DIRECT STEAM HEAT &		OIL LIGHTING
WIDTH " FRAMING	9'-8"	WHEELS	STEEL 36" DIA	N-W. STOVE		DRAFT GEAR
" " CROWN MOULD.	10'-1"	JOURNALS	SIZE 5" x 9"	2" HEATING PIPE =	FT.	FRICITION
CAPACITY	30000 LBS.	KIND OF TRUCK	METAL FACED			COUPLER 5" x 7" "E" SWIV. BUTT.

BUILT BY BARNEY & SMITH 1907 1911

214 to 217.  
218 to 226.

# BAGGAGE CAR N<sup>o</sup> 214 TO 226

20.

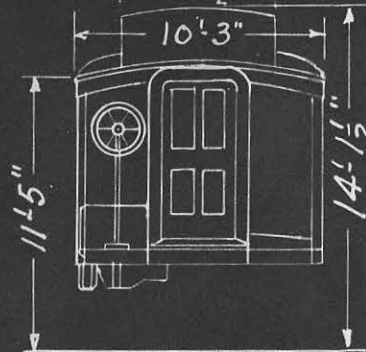

218 TO 226 HAVE  
TURTLE BACK ROOF.

- 214 FORMERLY 304
- 215 " 306
- 216 " 311
- 217 " 313
- 218 " 316
- 219 " 317
- 220 " 318
- 221 " 320
- 222 " 321
- 223 " 323
- 224 " 324
- 225 " 325
- 226 " 329

REF 65757

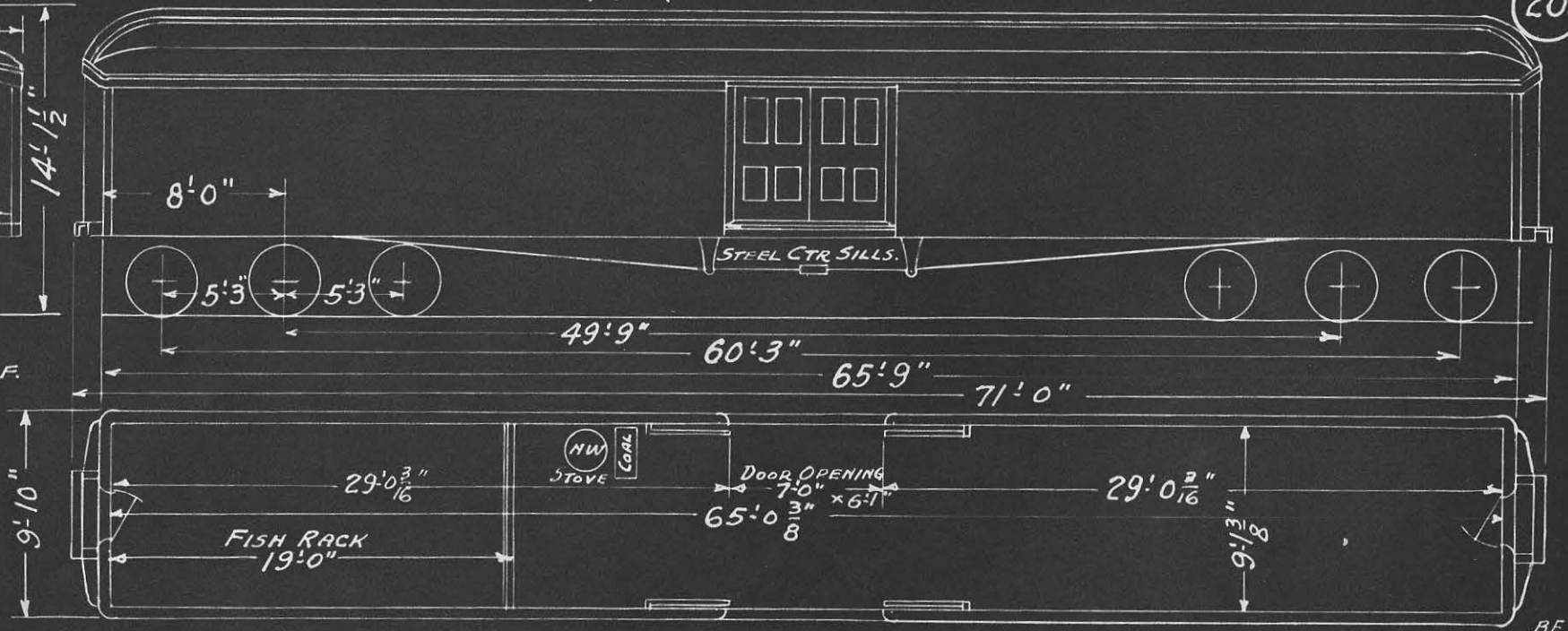

WEIGHT	112500 LBS.	TRUCK CENTERS	49'-9"	AIR BRAKE (214 TO 217)	14" x 12" CYL.	FINISH, EXT.	GROOVED SHEATHING
LENGTH OVER FRAMING	65'-9"	TOTAL WHEEL BASE	60'-3"	" " (218 TO 226)	16" x 12" "	" INT.	GROOVED LINING PAINTED
" " BUFFERS	71'-0"	TRUCK " "	10'-6"	" SIGNAL		HEAD LINING	BEADED CEILING
WIDTH " FRAMING	9'-10"	WHEELS - STEEL	36"	HEATER	N.W. STOVE WITH EXT. TOP.	LIGHTING	ELECTRIC
" " CROWN MLDG	10'-3"	KIND OF TRUCK	METAL FACED	HEATING	DIRECT ST. HEAT.	DRAFT GEAR	FRICTION
CAPACITY	50000 LBS.	JOURNALS	5" x 9"	HEATER PIPE	2" 300 FT.	COUPLER	5x7" "E" SWIV. BUTT.

5-26-43



BAGGAGE & EXPRESS Nos 227, 231.

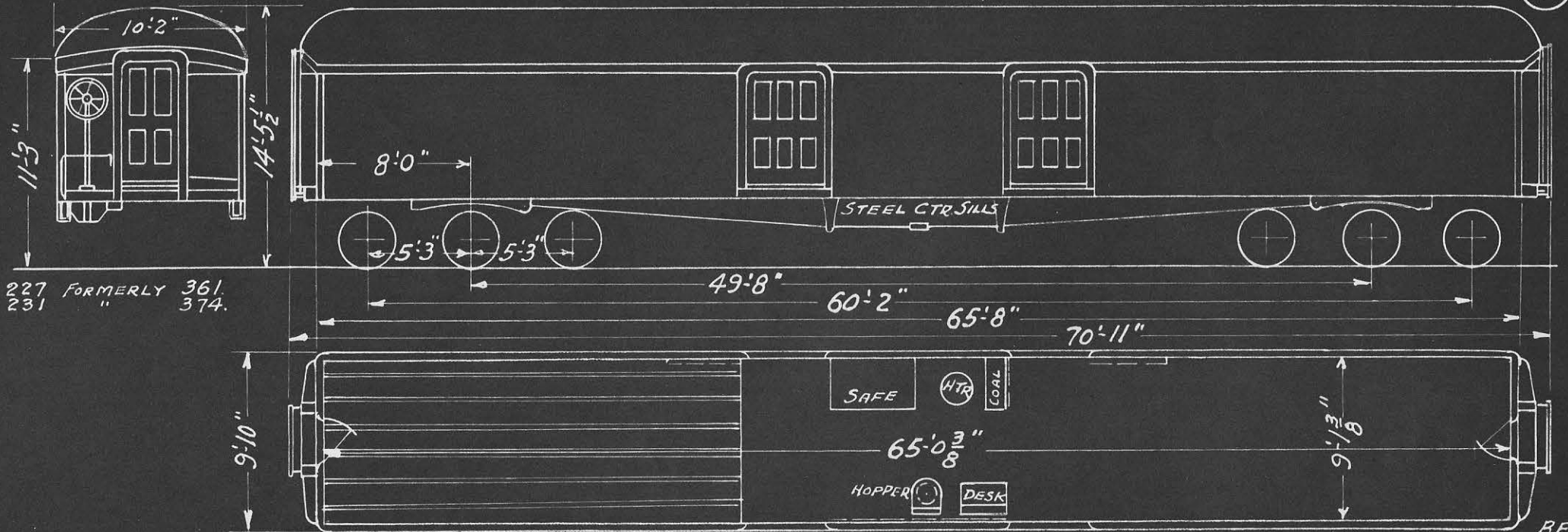

227 FORMERLY 361.  
231 " " 374.

WEIGHT	108000 LBS.	TRUCK CENTERS	49'-8"	AIR BRAKE	1-16"x12" CYL.	FINISH-EXT.	GROOVED SHEATHING
LENGTH OVER FRAMING	65'-8"	TOTAL WHEEL BASE	60'-2"	AIR SIGNAL		" -INT.	" LINING PAINTED
" " BUFFERS	70'-11"	TRUCK " "	10'-6"	HEATER N.W. STOVE HIGH CASING.		LIGHTING	ELECTRIC
WIDTH " FRAMING	9'-10"	WHEELS- STEEL	36" DIA	GOLD'S DIRECT STEAM.		DRAFT GEAR	FRICITION
" " CROWN MLDG.	10'-2"	KIND OF TRUCK	METAL FACED	HEATER PIPING 2"	260 FT.	COUPLER 5'x7" E"	SWIV. BUTT.
CAPACITY	50000 LBS.	JOURNALS	5"x9"				

52693

BUILT BY A.C.F. Co. 1906.

# BAGGAGE & EXPRESS CARS 228, 232, 234, 235, 236.

22

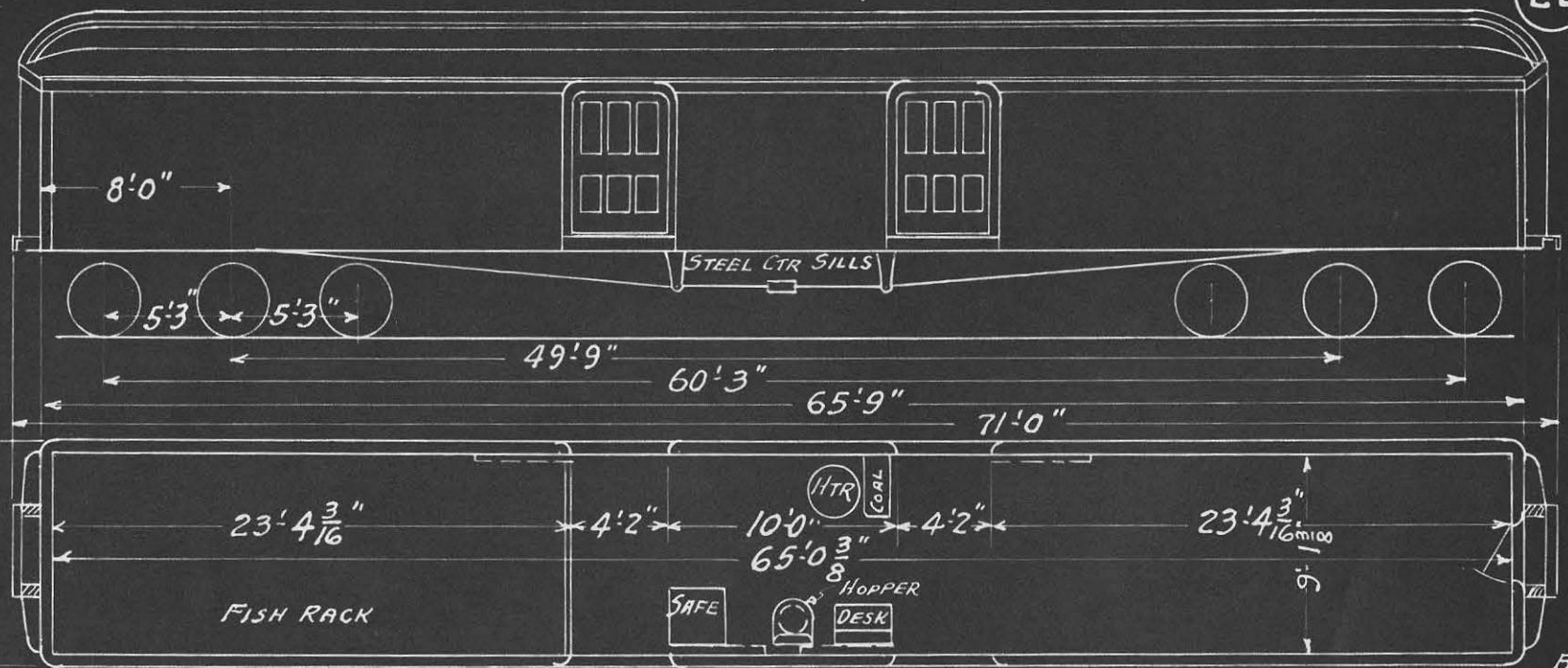
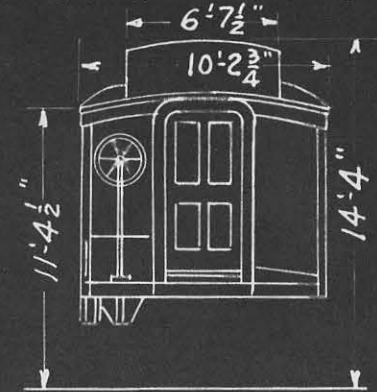

228	FORMERLY	366
232	"	384
234	"	392
235	"	393
236	"	394

WEIGHT	10000 LBS	TRUCK CENTERS	49'9"	AIR BRAKE	14"x12"CYL	FINISH EXT.	GROOVED SHEATHING
LENGTH OVER FRAMING	65'9"	TRUCK WHEEL BASE	10'6"	" SIGNAL		" INT.	GROOVED LINING PAINTED
" " BUFFERS	71'0"	TOTAL	60'3"	HEATER	N.W. STOVE	HEAD LINING	BEADED CEILING
WIDTH	FRAMING 9'10"	WHEELS - STEEL	36" DIA.	GOLD'S SYSTEM	DIRECT STEAM.	LIGHTING	ELECTRIC
" " CROWN MDG	10'2 3/4"	KIND OF TRUCK	METAL FACED.	HEATER PIPE	2"		
CAPACITY	50000 LBS	JOURNALS	5"x9"			DRAFT GEAR	FRICITION
						COUPLER	5"x7" "E" SWIV. BUTT

5-24-03

CHANGED FROM BAGG. & MAIL 1919

5-26-43  
REV. 10-1-22. REV. 5-1-24. REV. 3-1-26. REV. 6-1-30. REV. 3-17-39. 11-22-39. 12-15-41

AM. CAR & FDRY. CO. 1902.

BAGGAGE CAR NOS. 229, 230

23.

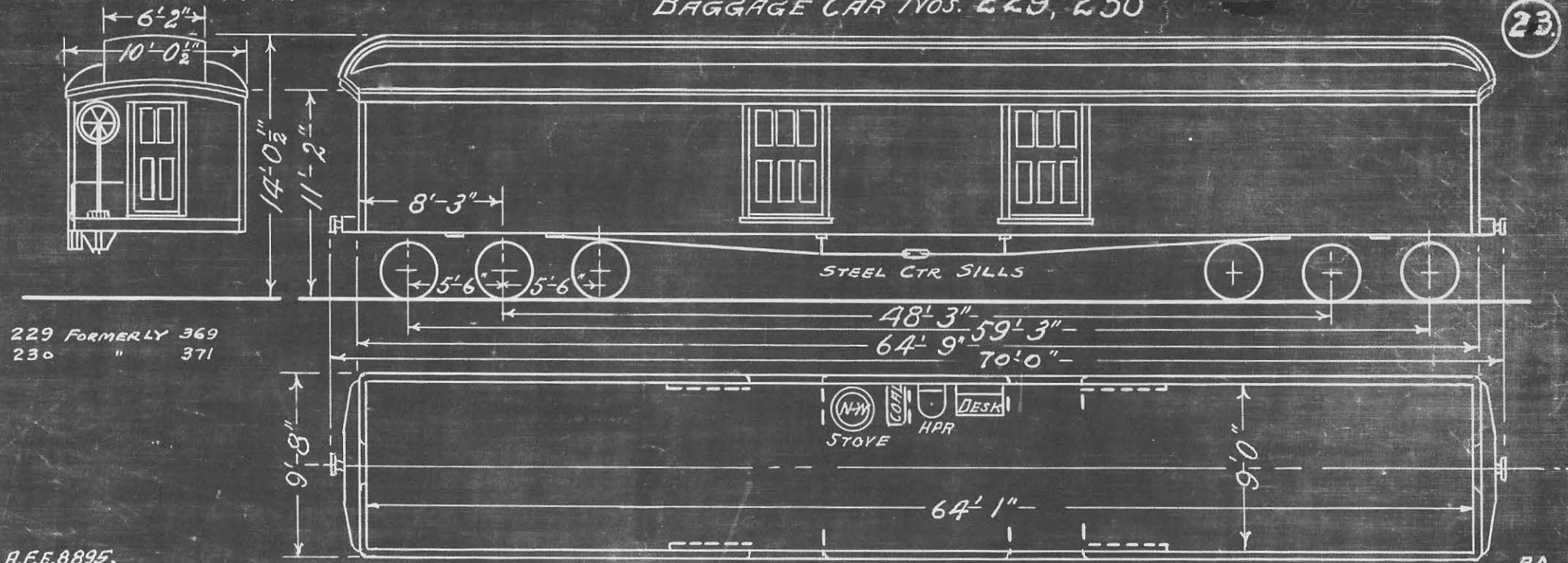

229 FORMERLY 369  
230 " 371

A.F.E. 8895.

WEIGHT	98000 LBS.	BOLSTER CENTERS	48'-3"	AIR BRAKE	1-14"x12" CYL.	OUTSIDE-GROOVED SHEATHING
LENGTH OVER FRAMING	64'-9"	TRUCK WHEEL BASE	11'-0"	AIR SIGNAL		INSIDE - BEADED LINING
" " BUFFERS	70'-0"	TOTAL " "	59'-3"	DIRECT STEAM HEAT AND		OIL LIGHTING
WIDTH " FRAMING	9'-8"	WHEELS STEEL	36" DIA.	N-W. STOVE		DRAFT GEAR
" " CROWN/MOULD.	10'-0 1/2"	JOURNALS SIZE	5" x 9"	2" HEATING PIPE =	FR.	FRACTION
CAPACITY	50000 LBS.	KIND OF TRUCK	METAL FACED			COUPLER 5"x7" "E" SWIVEL BUTT.



BUILT BY AM. CAR & FOUNDRY CO. 1902.

BAGGAGE & EXPRESS CAR No. 233

24

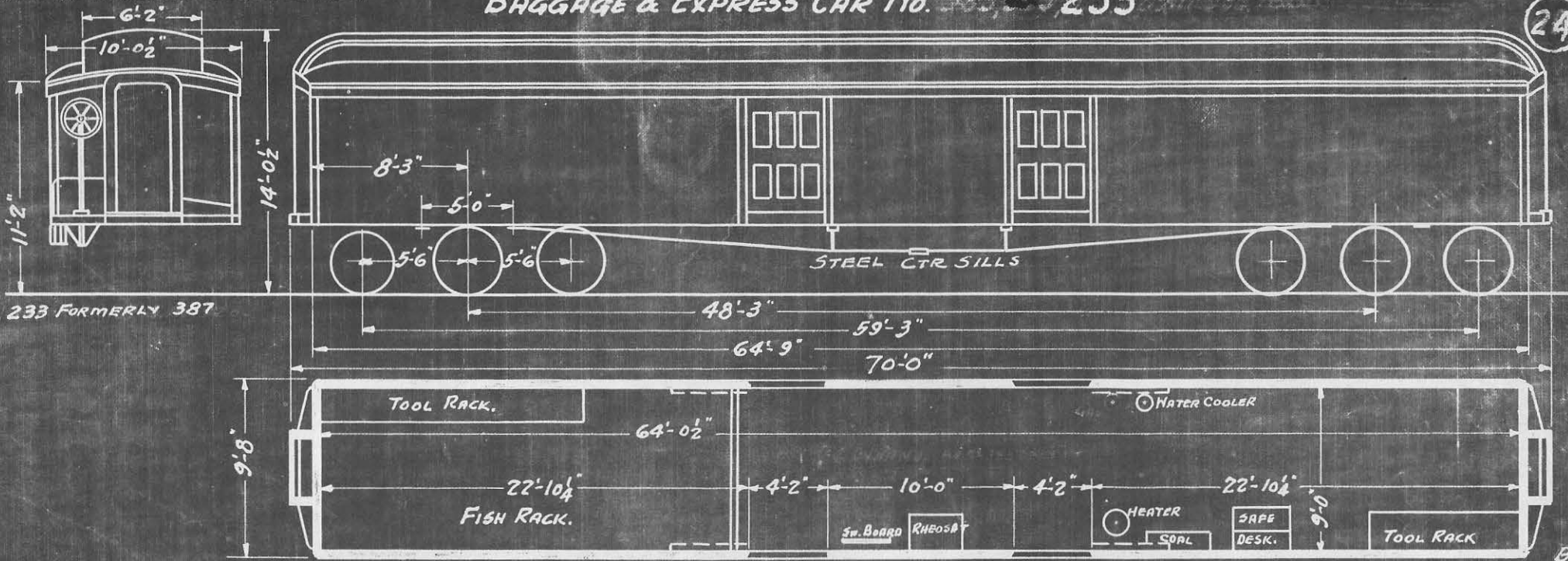

WEIGHT	96400 LBS.	TRUCK CENTERS	48'-3"	AIR BRAKE	14"x12" Cyl.	FINISH EXTERIOR	GROOVED SHEATHING
LENGTH OVER FRAMING	64'-9"	TOTAL WHEEL BASE	59'-3"	AIR SIGNAL		" INTERIOR	"
" " BUFFERS	70'-0"	TRUCK " "	11'-0"	HEATER	M.W. STOVE	HEADLINING	BEADED CEILING
WIDTH " FRAMING	9'-8"	WHEELS STEEL	DIA 36"		DIRECT STEAM	LIGHTING	ELECTRIC
" " CROWN MLDG	10'-0 1/2"	KIND OF TRUCK	METAL FACED	HEATER PIPING	1 1/2" 258 FT.	LAMPS	2-2 LT CENTER 2-1LT SIDE
CAPACITY	50000 LBS.	JOURNALS SIZE	5"x9"			DRAFT GEAR	FRICTION
						COUPLER	5x7" E SWIV. BUTT

5-26-43

REV. 5-1-24. REV. 3-1-26. REV. 3-1-28. REV. 6-1-30. REV. 12-18-31. REV. 3-17-39. 11-22-39.

BUILT BY A.C. & F. CO. 1910  
 INTERIOR REARRANGED 1928.

# BAGGAGE CAR Nos 241

25

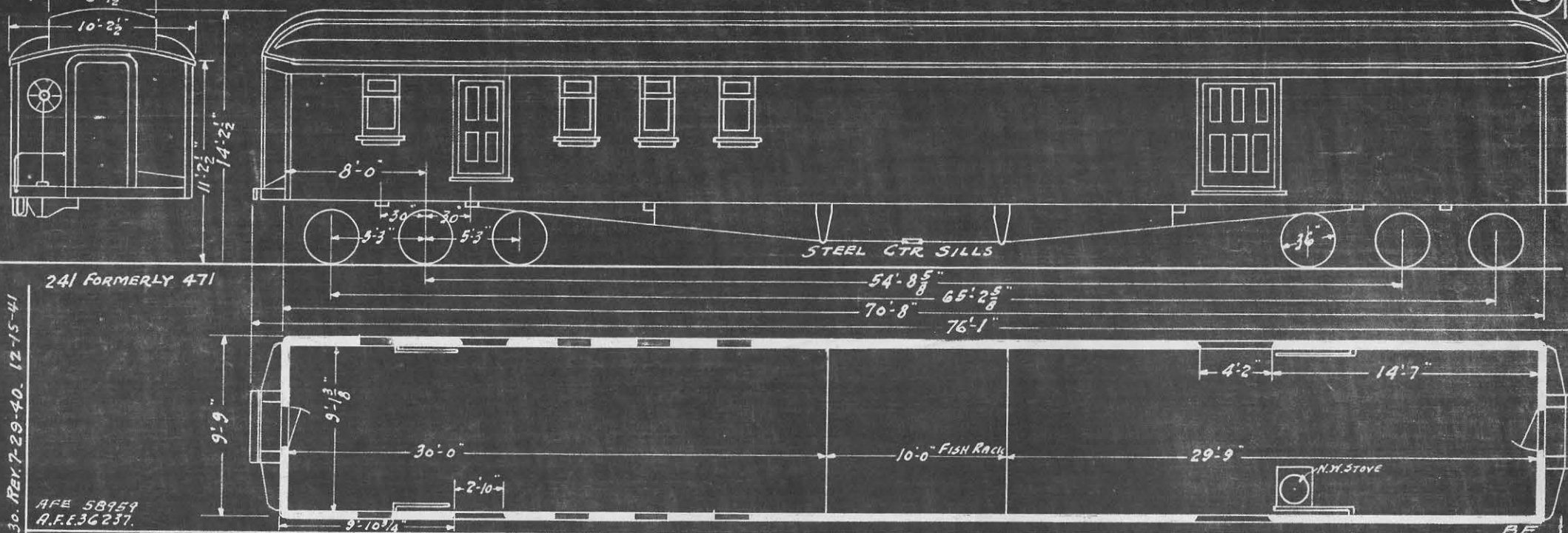

AFE 58959  
 A.F.E. 36237.

5-26-43  
 5-14-28 REV. 6-1-30. REV. 7-29-40. 12-15-41

WEIGHT	11000 LBS.	TRUCK CENTERS	54'-8 5/8"	AIR BRAKE	14"x12" CYL.	FINISH-EXTERIOR	GROOVED SHEATHING
LENGTH OVER FRAMING	70'-8"	TOTAL WHEEL BASE	65'-2 5/8"	" SIGNAL		" INTERIOR	BEADED LINING.
" " BUFFERS	76'-1"	TRUCK-	10'-6"	HEATER	N.Y. STOVE.	LIGHTING	OIL & ELECTRIC.
WIDTH " FRAMING	9'-9"	WHEELS	STEEL 36" DIA.	GOLD'S SYSTEM DIRECT STEAM HEAT.		DRAFT GEAR	FRICTION
" " CROWN MOLD'S	10'-2 1/2"	KIND OF TRUCK	METAL FACED.	HEATER PIPING	2"	FT. COUPLER	5"x7" "E" SWIV. BUTT.
CAPACITY	50000 LBS.	JOURNALS	SIZE 5"x9"				

BUILT BY A.C.B.F. Co. 1904-475 to 481, -1906-482,  
REARRANGED BY G.M. 1927,

# BAGGAGE CARS Nos 242 TO 248

26

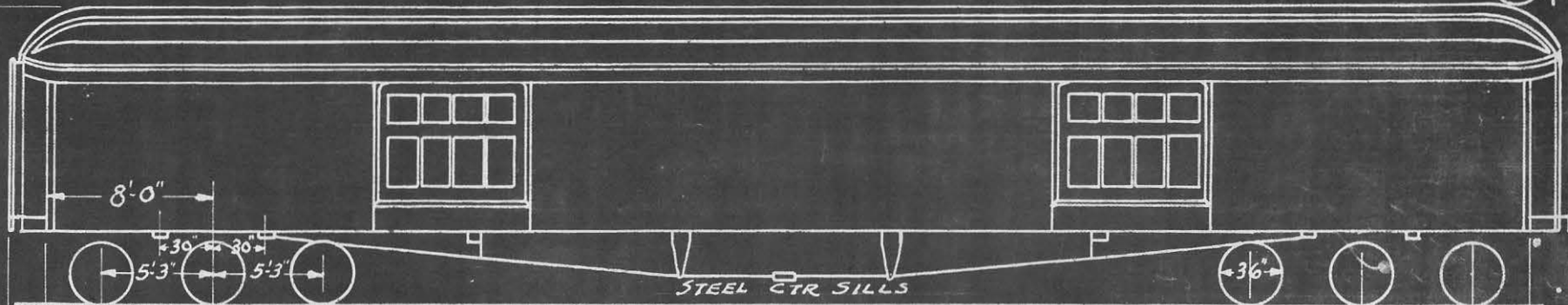
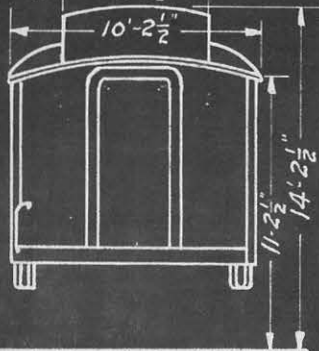

242 FORMERLY 475  
243 " 476  
244 " 477  
245 " 478  
246 " 479  
247 " 481  
248 " 482

APB 58959  
R.F.E. 34865

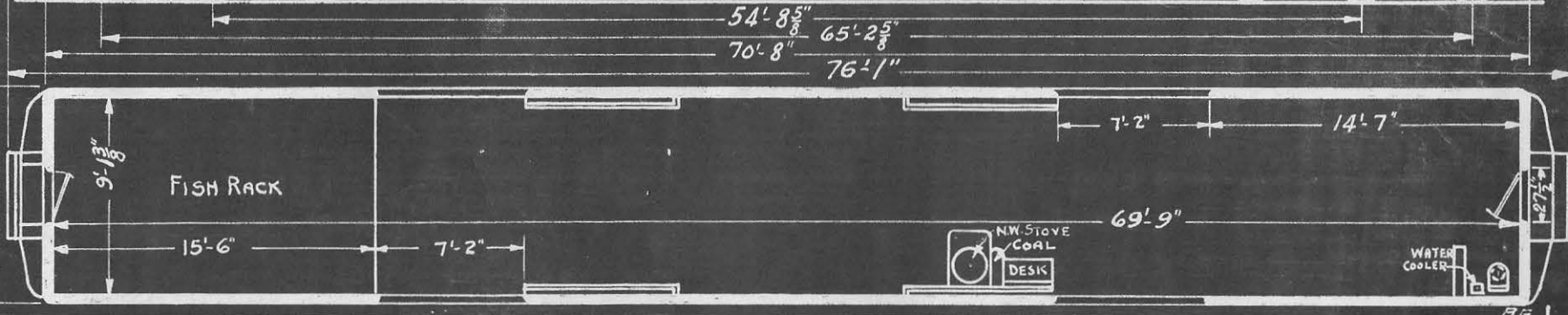

5-26-43

WEIGHT	114000 LBS.
LENGTH OVER FRAMING	70'-8"
" " BUFFERS	76'-1"
WIDTH " FRAMING	SEE PLAN
" " CROWN MOLD'G.	10'-2 1/2"
CAPACITY	50000 LBS.

TRUCK CENTERS	54'-8 5/8"
TOTAL WHEEL BASE	65'-2 3/8"
TRUCK " "	10'-6"
WHEELS	STEEL 36" DIA.
TRUCK	METAL FACED
JOURNALS	SIZE 5" x 9"

AIR BRAKE	CYL	14 x 12"
" SIGNAL		NEW YORK
HEATER		M.W. STOVE
		GOLD'S SYSTEM DIRECT STEAM HEAT
HEATER PIPING		2"

FINISH - EXTERIOR	GROOVED SHEATHING
" - INTERIOR	BEADED LINING
LIGHTING	ELECTRIC.
DRAFT GEAR	FRICTION
COUPLER	5x7 "E" SWIV. BUTT



REBUILT - G. N. - 1944  
FORMERLY DEPT. OF COMM. - CAR NO. 8

# BAGGAGE CAR No 259.

26  
A

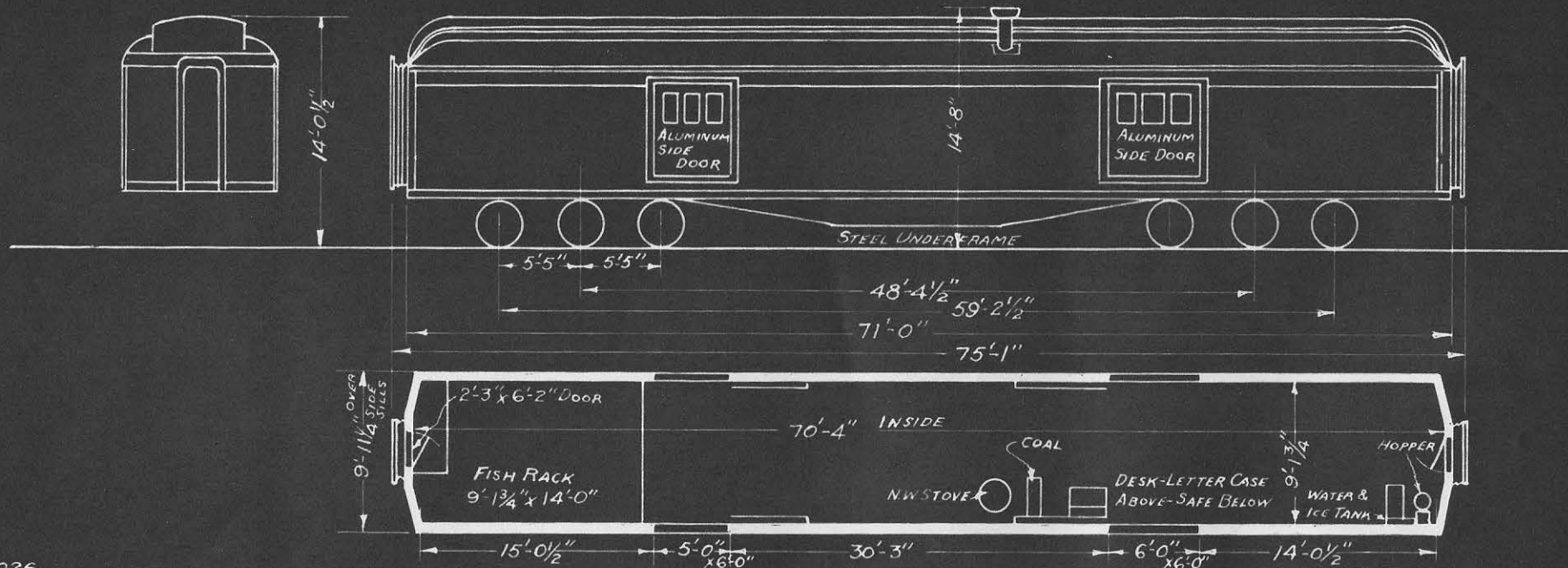

A.F.E. 68026.

WEIGHT _____	133900	TRUCK CENTERS _____	48'-4 1/2"	AIR BRAKE CYL. _____	2-14" x 12"	FINISH EXTERIOR _____	STEEL
LENGTH OVER FRAMING _____	71'-0"	WHEELBASE TOTAL _____	59'-2 1/2"	HEATING _____	1-N.W. STOVE	" INTERIOR _____	STEEL
" " BUFFERS _____	75'-1"	" " TRUCK _____	10'-10"	VAPOR HEAT _____	No 440	LIGHTING _____	AXLE GEN. 3K.W. ELECTRIC
WIDTH " SIDE SILLS _____	9'-11 1/4"	WHEELS _____ ROLLED STEEL	36" DIA.	TRIPLE VALVE _____	2- L3	BATTERIES _____	21 PLATE _____ M.V.A.H.
HEIGHT INSIDE _____	8'-5 3/4"	JOURNAL SIZE _____	5" x 9"			DRAFT GEAR _____	MINER _____
CAPACITY _____		KIND OF TRUCK _____	STEEL BUILT-UP			COUPLER _____	5" x 7" _____ SWIVEL BUTT

12-14-44

Rev. 6-1-25. Rev. 3-1-26. Rev. 3-1-28. Rev. 6-1-30. Rev. 9-12-32. 5-26-43  
 5-1-24. Rev. 6-13-24. CHANGED FROM BAGG. & CREEPY CAR NOS 1800 TO 1807. Rev. 12-15-24

BUILT BY B. & S. C. Co 1914  
 REBUILT BY G. H. Ry. 1924.

# BAGGAGE CAR Nos 260, 261

27

260 FORMERLY 235  
 261 " 237

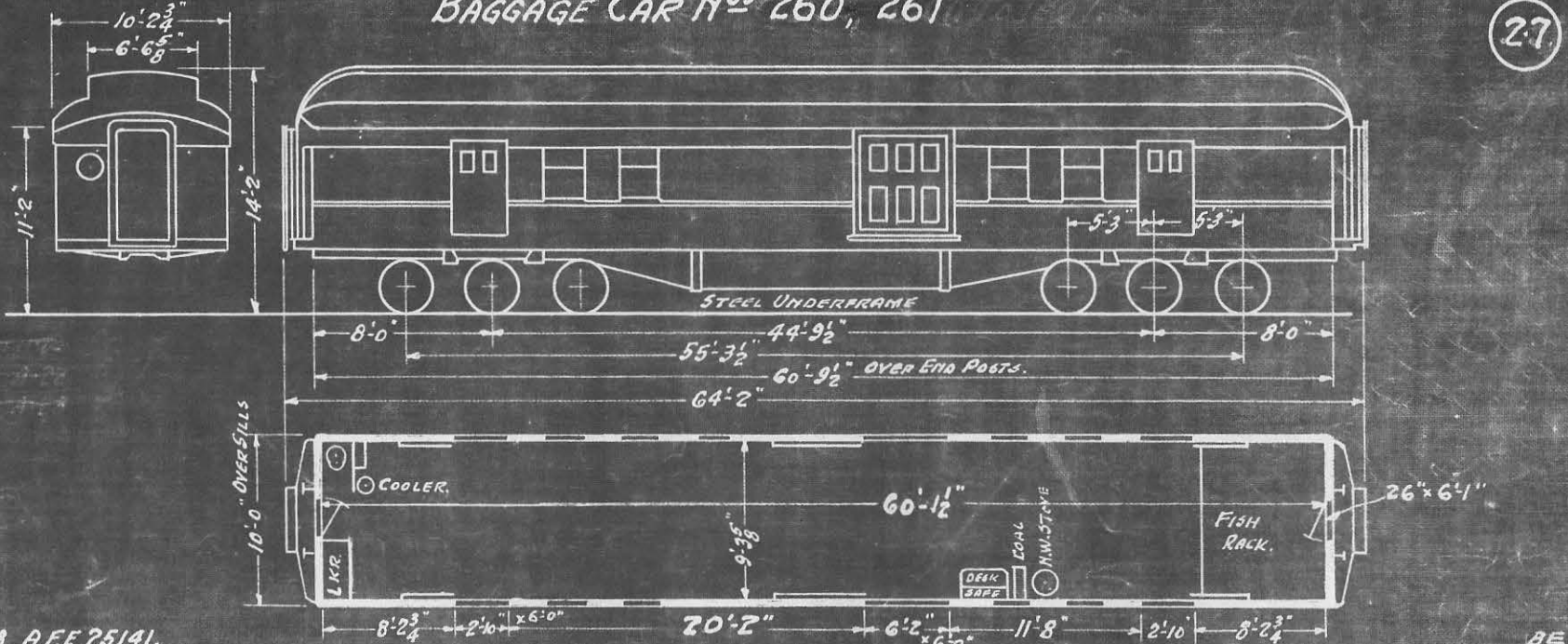

FORMERLY MAIL CAR Nos 11 TO 18. A.F.E 25141.

WEIGHT	128 000 LBS.	TRUCK CENTERS	44'-9 1/2"	AIR BRAKE	18 x 12 C.V.L.	FINISH-EXTERIOR	SHEET STEEL
LENGTH OVER FRAMING	60'-9 1/2"	WHEELBASE-TRUCKS	10'-6"	" SIGNAL		" INTERIOR	"
" " BUFFERS	64'-2"	" " TOTAL	55'-3 1/2"	HEAT	DIRECT STEAM	LIGHTING	AXLE GEN. ELECTRIC.
WIDTH " FRAMING	10'-0"	WHEELS-STEEL TIRES	36 1/2" DIA.	BODY BOLSTER	BUILT UP.	DRAFT GEAR	MINER.
" " CROWN MLD'G.	10'-2 3/4"	JOURNALS SIZE	5 x 9"	HEAT PIPING	2 1/2	COUPLER	5" x 7" E SWIV. BUTT.
		KIND OF TRUCKS	CAST STEEL.	STOVE			N.Y.

CAPACITY 50000 LBS.

Built by G.N.Ry.-1948

BAGGAGE CAR Nos. 270 to 272  
(Cor-Ten Steel)

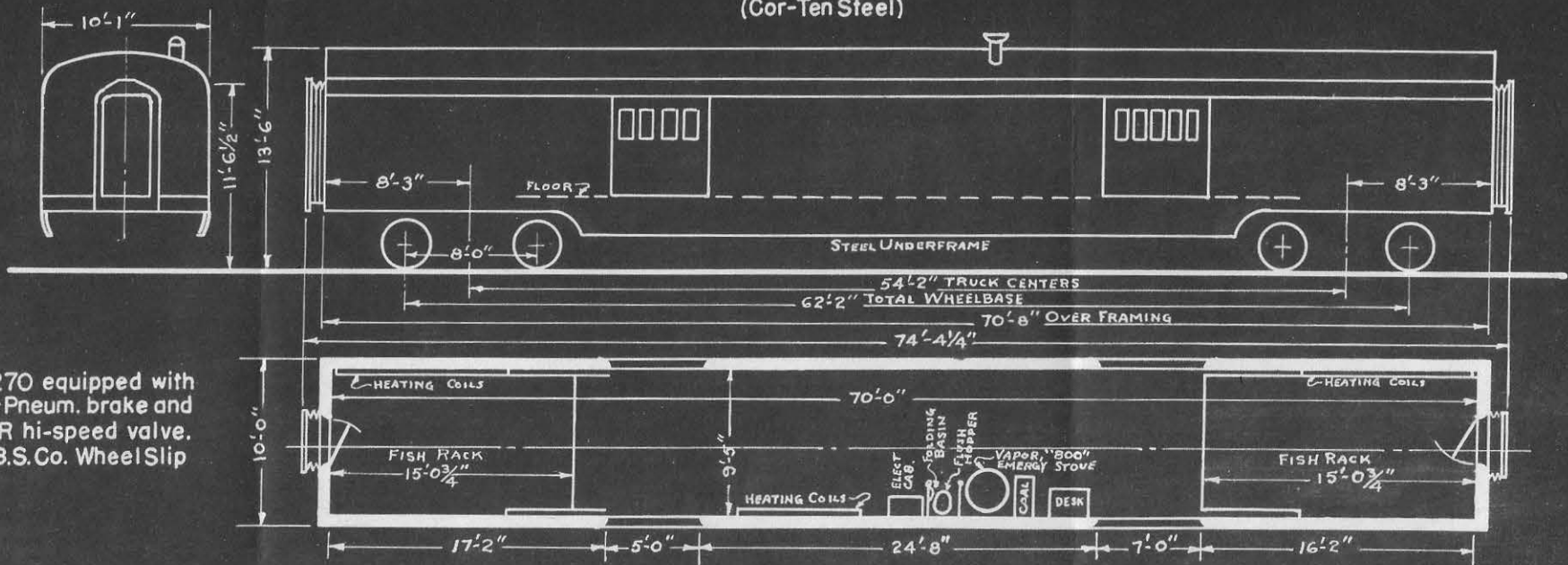

\*Note:- Car No. 270 equipped with Electro-Pneum. brake and D-22-BR hi-speed valve. Also A.B.S.Co. Wheel Slip Control

AFE 75803

BE

Weight _____	100000 Lbs.	Truck Centers _____	54'-2"	Air Brake* _____	H.S.C. _____	D-22-AR _____	Finish-Exterior _____	Painted Steel
Length Over Framing _____	70'-8"	Wheelbase-Truck _____	8'-0"	" " Cyls. _____	Trk.Mtd. _____	4-12"x10"	" -Interior _____	" "
" " Buffers _____	74'-4 1/4"	" -Total _____	62'-2"	" Conditioning _____	_____	None	Lighting _____	Axle Gen. _____
Width " Framing _____	10'-0"	Wheels _____	36"	Heating _____	Fin Rad _____	Vapor	Draft Gear _____	A-5-XB _____
" " Crown Mldg. _____	10'-1"	Journals _____	6"x11"					Miner
Capacity (Bagg.) _____	70000 Lbs.	Kind Of Truck _____	Cast Steel				Coupler _____	Swivel Butt _____
		Brakes _____	Clasp					5"x7"



BUILT BY A.C.&F. Co. 1913  
 STEEL SHEATHING APPLIED 1927

65 FT BAGGAGE CAR No 330,336,338.

28.

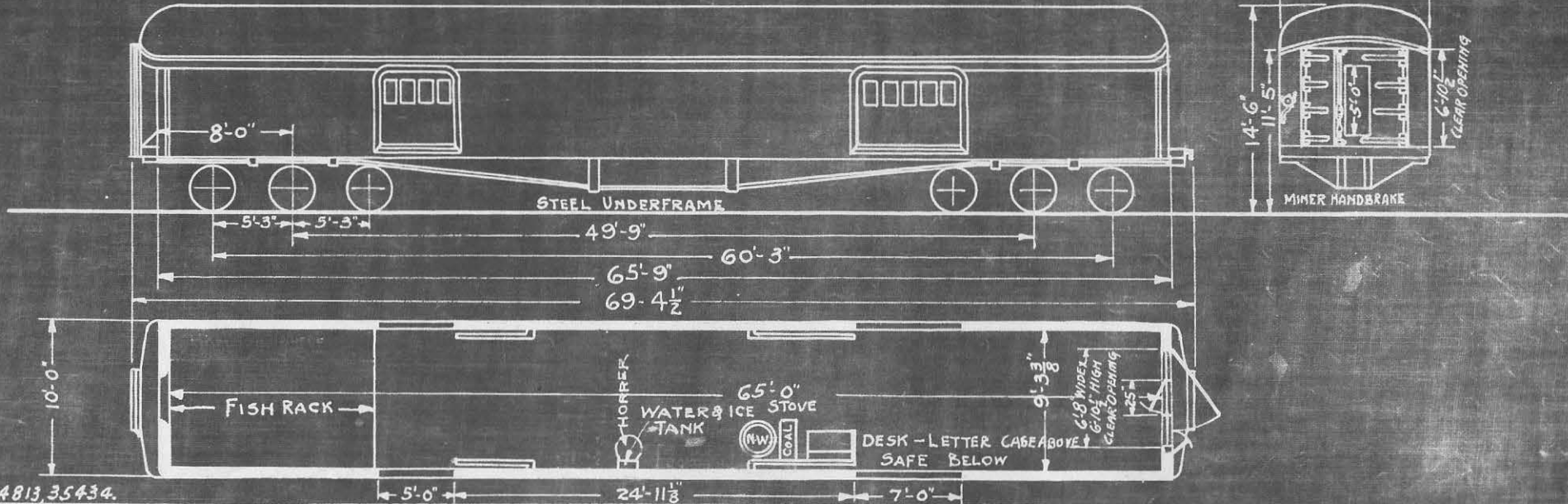

A.F.F. 34813, 35434.

WEIGHT, LBS. — 113800	TRANSOM CENTERS — 49'-9"	AIR BRAKE CYLINDER — 16"	OUTSIDE FINISH, SHEET STEEL
LENGTH OVER FRAMING — 65'-9"	TOTAL WHEEL BASE — 60'-3"	AIR SIGNAL — N.Y.	INSIDE FINISH, GR. LINING
LENGTH " BUFFERS — 69'-4 1/2"	TRUCK " " — 10'-6"	HEATER, N.W. STOVE	LIGHTING, ELECTRIC
WIDTH OVER FRAMING — 10'-0"	WHEELS, STEEL TIRED — 36 1/2"	HEATING, GOLD SYSTEM, DIRECT	LAMPS, 14 ELECTR-
WIDTH " CROWN MLDG. — 10'-4 3/4"	KIND OF TRUCK — METAL FACED	DUMMY VESTIBULES	DRAFT RIGGING — FARLOW
CAPACITY, LBS. — 50000	JOURNALS — 5'x 9"		COUPLER — SHORT SHANK — 6 1/2" BUTT.

8-17-27 REV. 3-1-28 REV. 2-26-29 REV. 6-1-30 REV. 6-8-31 REV. 12-18-31. 5-26-43

Rev. 6.8.31. Rev. 12.18.31. Rev. 9.12.32. 12.15.41 5-26-43  
 Rev. 5-1-24. Rev. 6-1-25. Rev. 3-1-26. Rev. 8-17-27. Rev. 9-15-27. Rev. 3-1-28. Rev. 6-1-30.

CAR No.	BUILDER	YEAR
331 To 333, 335, 337	A.C. & F. Co.	1913
339 To 343	A.C. & F. Co.	1913
345 To 349	A.C. & F. Co.	1913

## 65 FT BAGGAGE CAR STEEL UNDERFRAME

29.

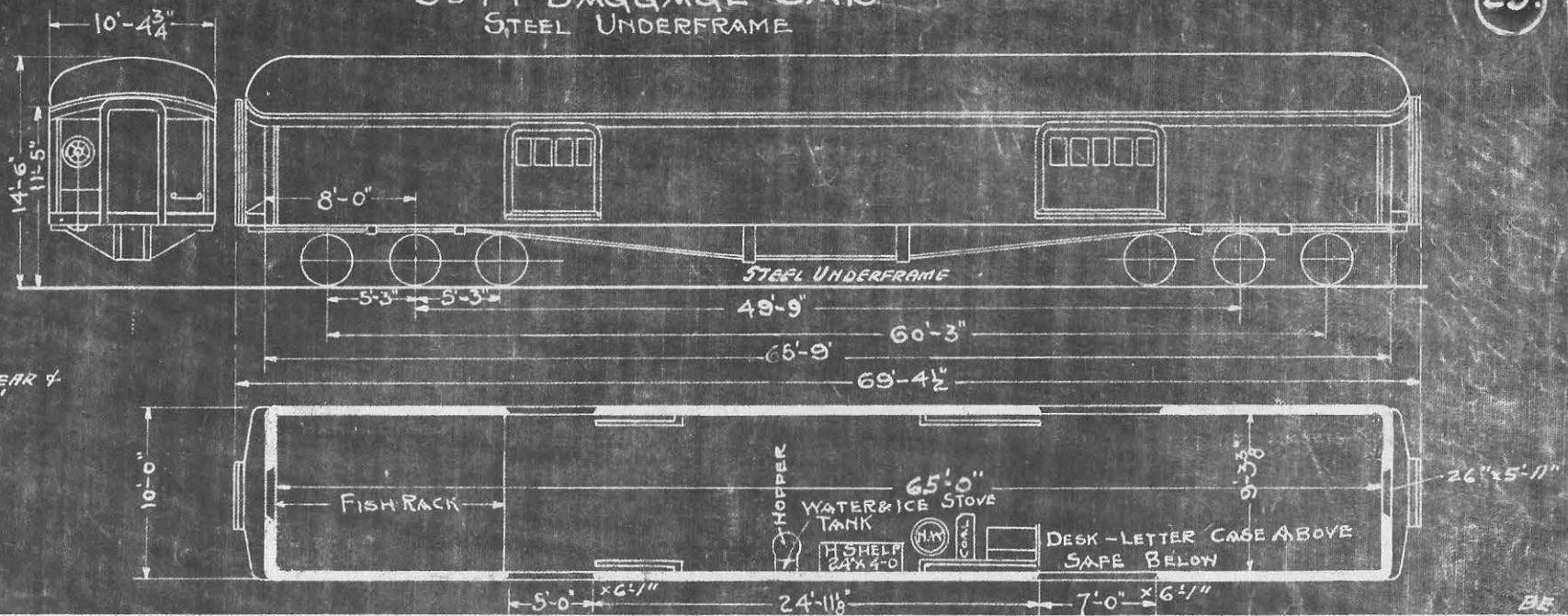

x343, 340, 334  
EQUIPPED WITH MINER GEAR &  
SWIVEL COUPLER "E"

WEIGHT, LBS.	109800	TRANSOM CENTERS,	49'-9"	AIR BRAKE CYLINDER	16"x12"	OUTSIDE FINISH, GR. SHEATHING
LENGTH OVER FRAMING,	65'-9"	TOTAL WHEEL BASE,	60'-3"	AIR SIGNAL,		INSIDE FINISH, GR. LINING
LENGTH " BUFFERS,	69'-4 1/2"	TRUCK " "	10'-6"	HEATER, N.Y. STOVE		LIGHTING, ELECTRIC
WIDTH OVER FRAMING,	10'-0"	WHEELS, STEEL TIRED	36 1/2"	HEATING, GOLD SYSTEM, DIRECT		LAMPS, 14 ELECTR.
WIDTH " CROWN MILD'G,	10'-4 3/4"	KIND OF TRUCK	METAL FACED	DUMMY VESTIBULES		*DRAFT RIGGING, *FARLOW
CAPACITY, LBS.	65000	JOURNALS,	5 x 9"			*COUPLERS * SHORT SHANK 6 1/2" BUTT.

BUILT BY A.C.&F.Co.-1913  
STEEL SHEATHING APPLIED-1927

# BAGGAGE CAR No 344,334.

30.

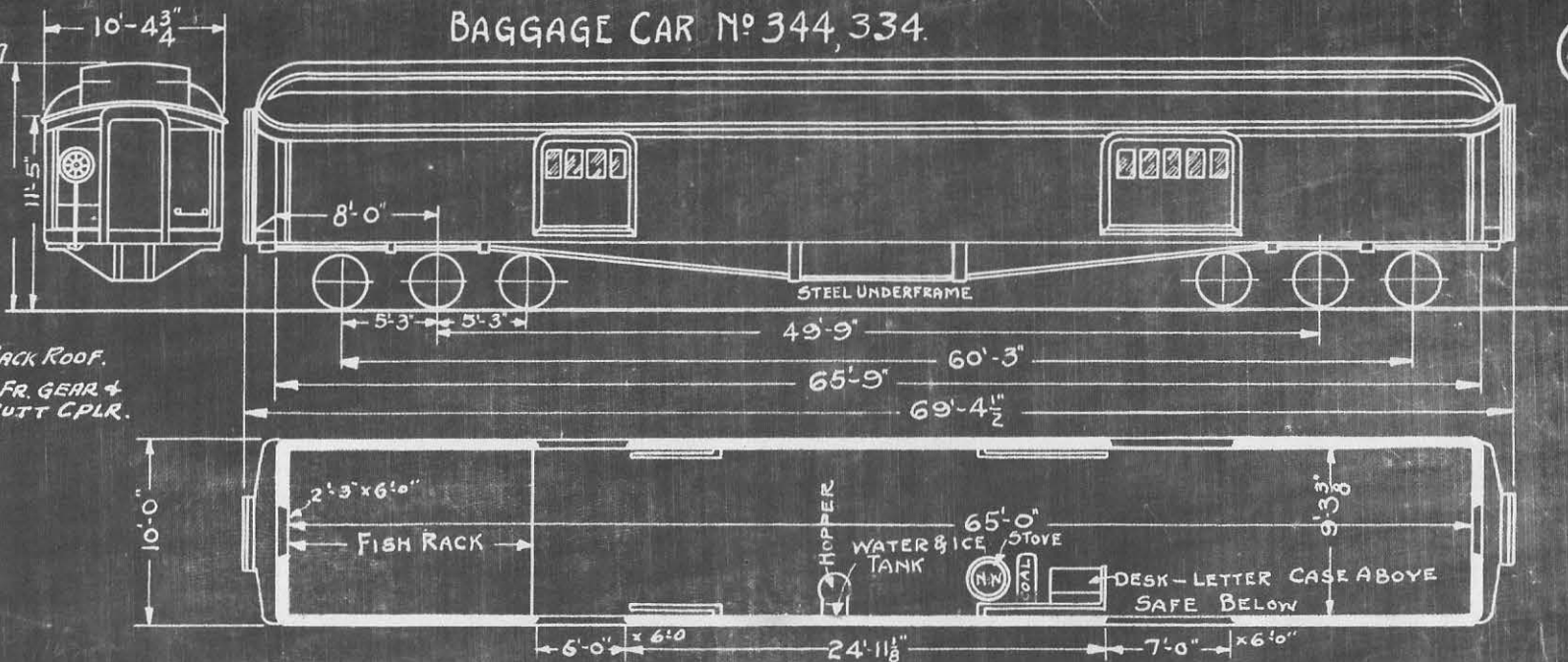

CAR No 334 HAS TURTLE BACK ROOF.  
X " " 334 HAS MINER FR. GEAR & 5x7 "E" SWIV. BUTT CPLR.

AFE 34329, 34813

WEIGHT, LBS. ———— 116300	TRANSOM CENTERS ———— 49'-9"	AIR BRAKE — CYLINDER — 16" x 12"	OUTSIDE FINISH ———— STEEL
LENGTH OVER FRAMING ———— 65'-9"	TOTAL WHEEL BASE ———— 60'-3"	AIR SIGNAL ————	INSIDE FINISH ———— GR. LINING
LENGTH " BUFFERS ———— 69'-4 1/2"	TRUCK " " ———— 10'-6"	HEATER ———— N.W. STOVE	LIGHTING ———— ELECTRIC
WIDTH OVER FRAMING ———— 10'-0"	WHEELS, STEEL TIRED ———— 36 1/2"	HEATING, GOLD SYSTEM ———— DIRECT	LAMPS — 14 ELECTRIC
WIDTH " CROWN MLD'G ———— 10'-4 3/4"	KIND OF TRUCK ———— METAL FACED	DUMMY VESTIBULES ————	DRAFT RIGGING ———— X FARLOW
CAPACITY, LBS. ———— 50000	JOURNALS ———— 5" x 9"		COUPLERS X SHORT SHANK, 6 1/2" BUTT.

9-15-27  
REV. 2-26-29. REV. 6-1-30. REV. 6-8-31. REV. 12-18-31. 5-26-43



5-26-43  
 Rev. 6-1-25. Rev. 3-1-26. Rev. 9-24-26. Rev. 3-1-28. Rev. 6-1-30. Rev. 6-8-31. Rev. 12-19-31.  
 FORMERLY B & E. Nos. 1689 To 1702. Rev. 5-1-24. Rev. 12-15-24. Rev. 3-7-25.

BUILT BY BARNEY & SMITH CO. 1909.  
 STEEL UNDERFRAME & SHEATHING APPLIED

BAGGAGE & EXPRESS Nos. 350 To 357, 360, 362, 364, 365.

(31)

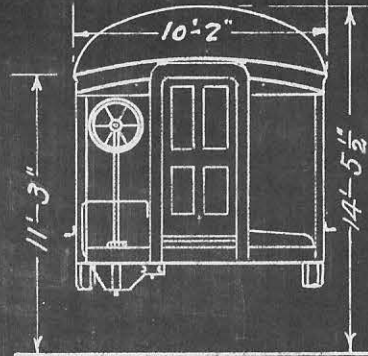

\*360, 362 HAVE FRICTION GEAR  
 & 5x7" E SWIVEL  
 BUTT COUPLER

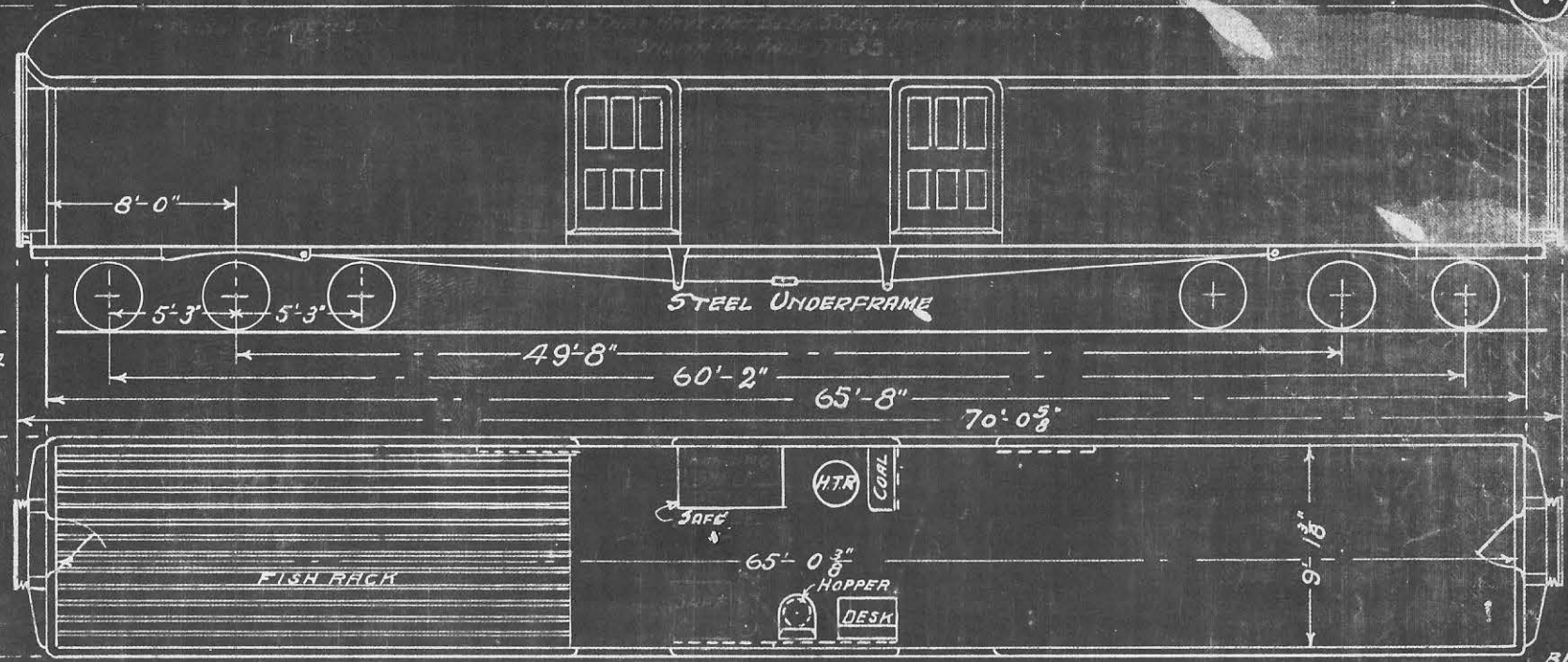

A.F.E. 19749

WEIGHT, 129300 LBS.  
 LENGTH OVER FRAMING, 65'-8"  
 LENGTH OVER BUFFERS, 70'-0 5/8"  
 WIDTH OVER FRAMING, 9'-10"  
 WIDTH OVER CROW MLDG., 10'-2"  
 CAPACITY, 50000 LBS.

TRANSOM CENTERS, 49'-8"  
 TOTAL WHEEL BASE, 60'-2"  
 TRUCK " " 10'-6"  
 WHEELS, STEEL 36" DIAM.  
 KIND OF TRUCK . METAL FACED  
 JOURNALS 5"x9".

AIR BRAKE, 2-16x12 CYL. N.Y.A.B.C.  
 AIR SIGNAL, " "  
 HEATER, N.W. STOVE-HIGH CASING  
 GOLDS DIRECT STEAM, 260', 2" PIPE.  
 TEN 9" JAPANESE VENTILATORS  
 DRAFT GEAR X MINER A-5-P-X.

FINISH, EXTERIOR, STEEL SHEATHING  
 FINISH, INTERIOR, GRVD. LINING PAINTED  
 LIGHTING, " " ELECTRIC.  
 LAMPS  
 12-1LT. ELECTRIC.  
 COUPLER SHORT SHANK 9 1/2" BUTT.

BUILT BY BARNEY & SMITH CO 1909.  
STEEL UNDERFRAME & SHEATHING APPLIED 1925.

# BAGGAGE & EXPRESS No 358.

32.

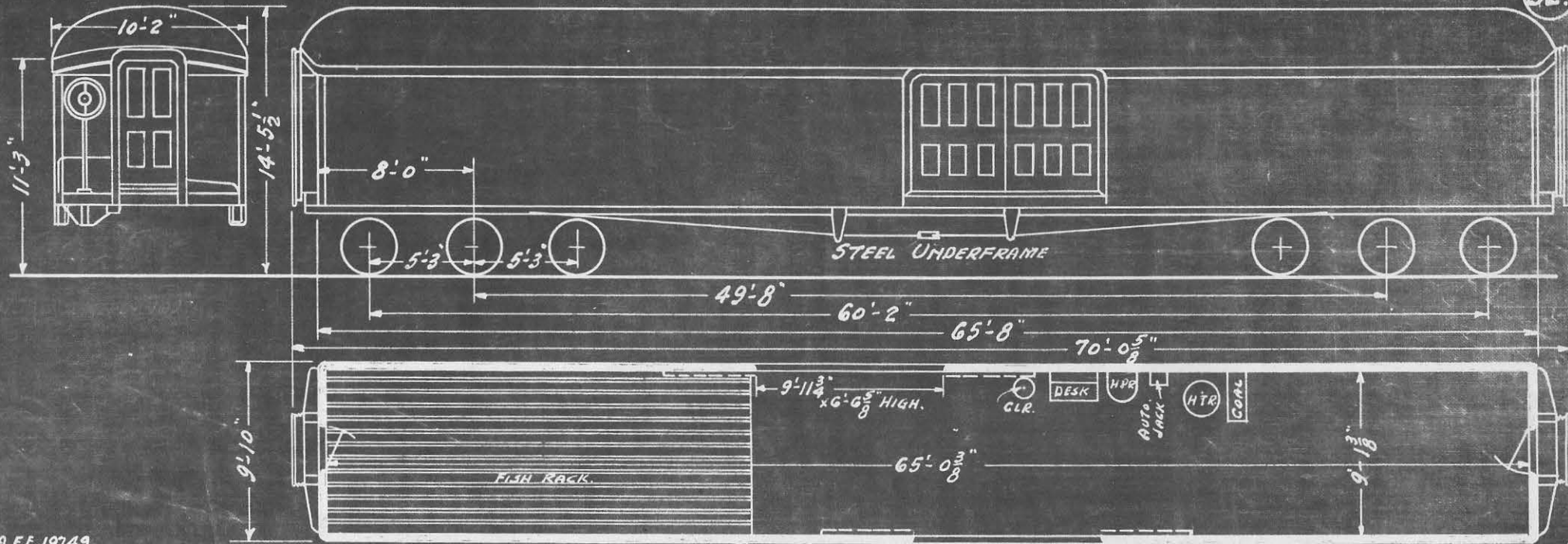

A.F.E. 19749.

WEIGHT	127800 LBS.	TRUCK CENTERS	49'-8"	AIR BRAKE	2-16" x 12" CYL. N.Y.A.B.CO	FINISH, EXTERIOR	STEEL SHEATHING.
LENGTH OVER FRAMING	65'-8"	WHEEL BASE TOTAL	60'-2"	AIR SIGNAL	" "	" INTERIOR	GRV'D. LINING PAINTED.
" " BUFFERS	70'-0 5/8"	" " TRUCK	10'-6"	HEATER	N.Y. STOVE HIGH CASING.	LIGHTING	ELECTRIC.
WIDTH " FRAMING	9'-10"	WHEELS STEEL TIRED	36" DIA.	GOLD'S DIRECT STEAM	260'-2" PIPE.	DRAFT GEAR	MINER A-5-P.X
" " CROWN MLDG.	10'-2"	JOURNALS SIZE	5" x 9"	TEN 9" JAPANESE VENTILATORS.		COUPLER	SHORT SHANK, 9 3/8" BUTT.
CAPACITY	50000 LBS.	KIND OF TRUCK	METAL FACED				

3-7-25 Rev. 3-1-26. REV. 6-1-30. 5-26-43

Rev. 3-1-26. Rev. 3-1-28. Rev. 6-21-28. Rev. 6-1-30. 5-26-43  
 FORMERLY B. & E. Nos. 1673 TO 1688. Rev. 7-1-23. Rev. 5-1-24. Rev. 12-15-24

BUILT BY BARNEY & SMITH CO. 1909.  
 STEEL UNDERFRAME & SHEATHING APPLIED

DYNAMO-BAGGAGE CAR Nos. 372, 373, 377 TO 380.

33.

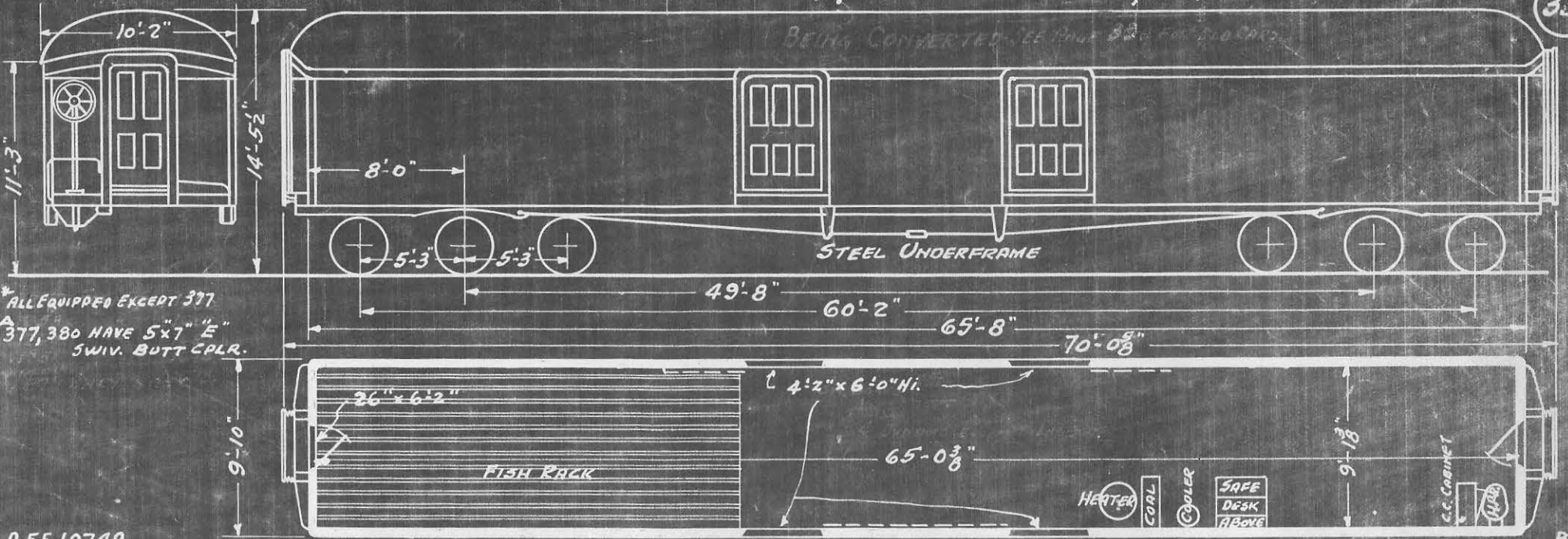

ALL EQUIPPED EXCEPT 377  
 377, 380 HAVE 5x7 "E"  
 SWIV. BUTT CPLR.

A.F.E. 19749.

WEIGHT	138500 LBS.	TRUCK CENTERS	49'-8"	AIR BRAKE	2-18x12 CYL. NEW YORK CO.	FINISH EXTERIOR	STEEL SHEATHING
LENGTH OVER FRAMING	65'-8"	TOTAL WHEEL BASE	60'-2"	AIR SIGNAL	" " " " " "	" INTERIOR	GROOVED LINING PAINTED
" " BUFFERS	70'-0 3/8"	TRUCK " "	10'-6"	HEATER	M.Y. STOVE. HIGH CASING	LIGHTING	AXLEGEN " ELECTRIC
WIDTH " FRAMING	9'-10"	WHEELS STEEL	DIAM. 36"	GOLDS DIRECT STEAM		LAMPS	6-2 1/2 EL. C.
" " CROWN MLDG.	10'-2"	KIND OF TRUCK	METAL FACED.	HEATER PIPING	2"	DRAFT GEAR	MINER - A-5-P-X
CAPACITY	50000 LBS.	JOURNALS	5" x 9"	VENTILATORS	TEN 9" JAPANESE	COUPLER	A SHORT SHANK 9 3/8 BUTT.



BUILT BY A.C. & F. Co-1906  
 STEEL UNDERFRAME & STEEL SHEATHING APPLIED-1927

# BAGGAGE CAR No 399

34

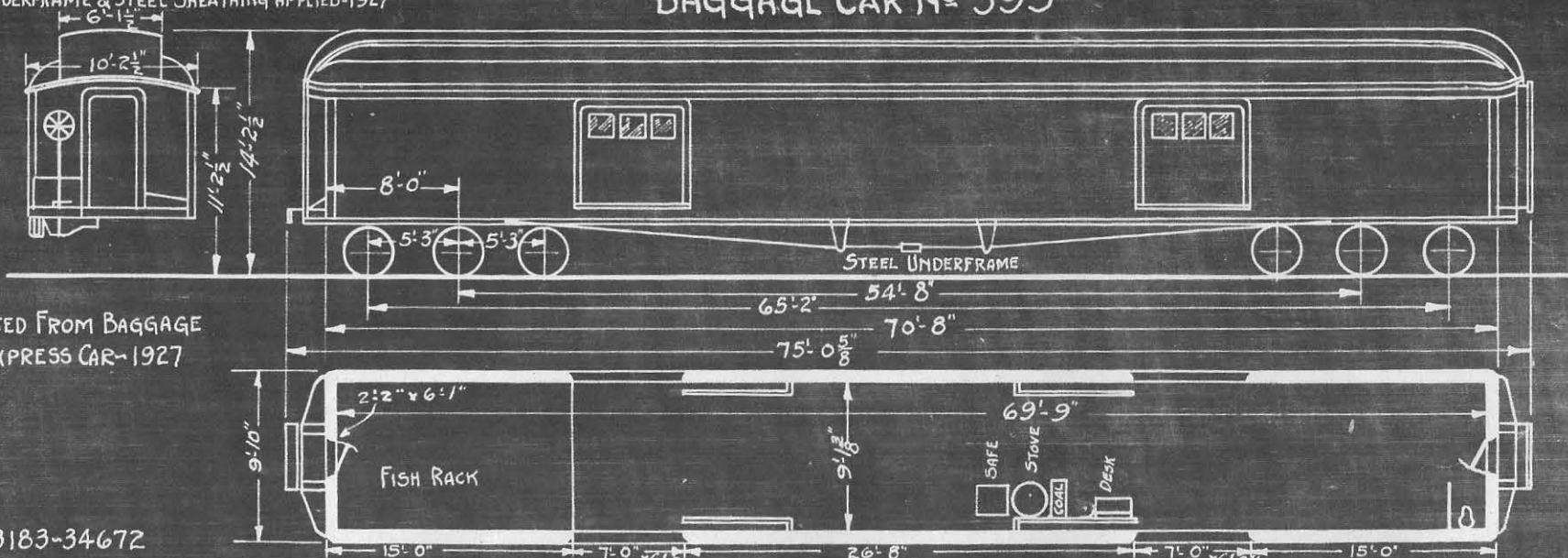

CONVERTED FROM BAGGAGE  
 MAIL & EXPRESS CAR-1927

A.F.E. 33183-34672

9-14-27, REV. 6-1-30, REV. 6-8-31, REV. 12-18-31, 5-26-43

WEIGHT-LBS. _____	131000	TRUCK CENTERS _____	54'-8"	AIR BRAKE _____ CYLINDER _____	2-16" x 12"	FINISH EXTERIOR _____	STEEL
LENGTH OVER FRAMING _____	70'-8"	TOTAL WHEEL BASE _____	65'-2"	" SIGNAL _____		" INTERIOR _____	BEADED LINING
" " BUFFERS _____	75'-0 5/8"	TRUCK " " _____	10'-6"	COUPLER _____ TYPE "D" _____	5' x 7" SHANK	LIGHTING _____	OIL & ELECTRIC
WIDTH " FRAMING _____	9'-10"	WHEELS _____ STEEL _____	36" DIA.	TRIPLE VALVE _____	L-3	DRAFT GEAR _____	MINER A-5-P.X.
" " CROWN MOULDING _____	10'-2 1/2"	KIND OF TRUCK _____	METAL FACED	HEATER _____	M.W. STOVE	COUPLER _____	SHORT SHANK 9 1/2" BUTT.
CAPACITY _____	50000 LBS.	JOURNALS SIZE _____	5' x 9"	GOLD'S SYSTEM DIRECT STEAM HEAT			

REV. 5-2-41 5-26-43

9-24-26 (REV. 10-23-23, REV. 9-15-27, REV. 10-7-27, REV. 6-1-30, REV. 6-8-31, REV. 12-18-31)

BUILT BY G.M.RY. 1926 FROM 8200 CL. SLEEPERS - 400 TO 409  
 UNDERFRAME BUILT BY SIEMIS-STEMBEL 1926 - 400 TO 409  
 " " " " 1927 - 410 TO 419  
 BUILT BY G.M.RY. 1927 FROM 8200 CL. SLEEPERS 410 TO 418

## 72'-6" BAGGAGE CAR Nos 400 TO 409 410 TO 418

35

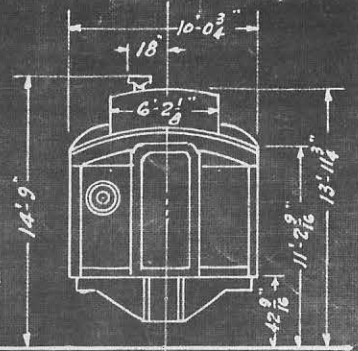
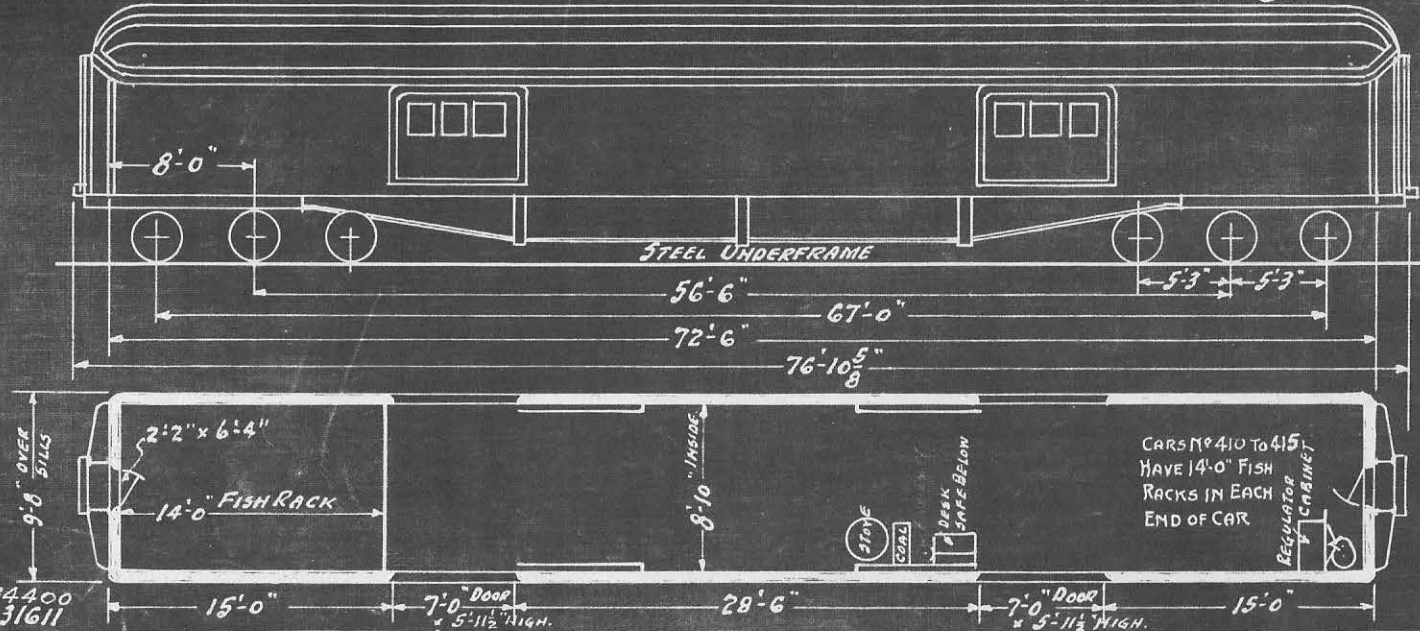

403  
410  
411  
+ CAR 416 } SWIVEL BUTT COUPLER  
415  
402

Δ 403 HAS WEST' HSE GEAR.

A.F.F. 34400  
A.F.F. 31611

WEIGHT	14100 LBS.	TRUCK CENTERS	56'-6"	AIR BRAKE	2-14" x 12" NEW YORK	OUTSIDE FINISH	SHEET STEEL
LENGTH OVER FRAMING	72'-6"	WHEELBASE - TRUCK	10'-6"	AIR SIGNAL	"	INSIDE	BEADED SHEATHING
" " BUFFERS	76'-10 5/8"	" " - TOTAL	67'-0"	CLASP BRAKE	SIMPLEX	HEAD LINING	3PLY VENEER PAINTED
WIDTH " FRAMING	9'-8"	WHEELS	ROLLED STEEL 36" DIA.	HEATER	M.Y. STOVE	LIGHTING	AXLE GEN. ELECTRIC.
" " CROWN MLDG.	10'-0 3/4"	JOURNALS	SIZE 5 1/2" x 10"	VAPOR HEAT		DRAFT GEAR	Δ MINER A-S-P-X
CAPACITY	72000 LBS.	KIND OF TRUCK	METAL FACED.	U-12 VALVE		COUPLER+	SHORT SHANK 9 3/8" BUTT.

BE

BUILT BY A.C. & F. Co. 1913.  
STEEL SHEATH APPLIED 1924.

# BAGGAGE CAR No 419

36

FORMERLY CAR #653.

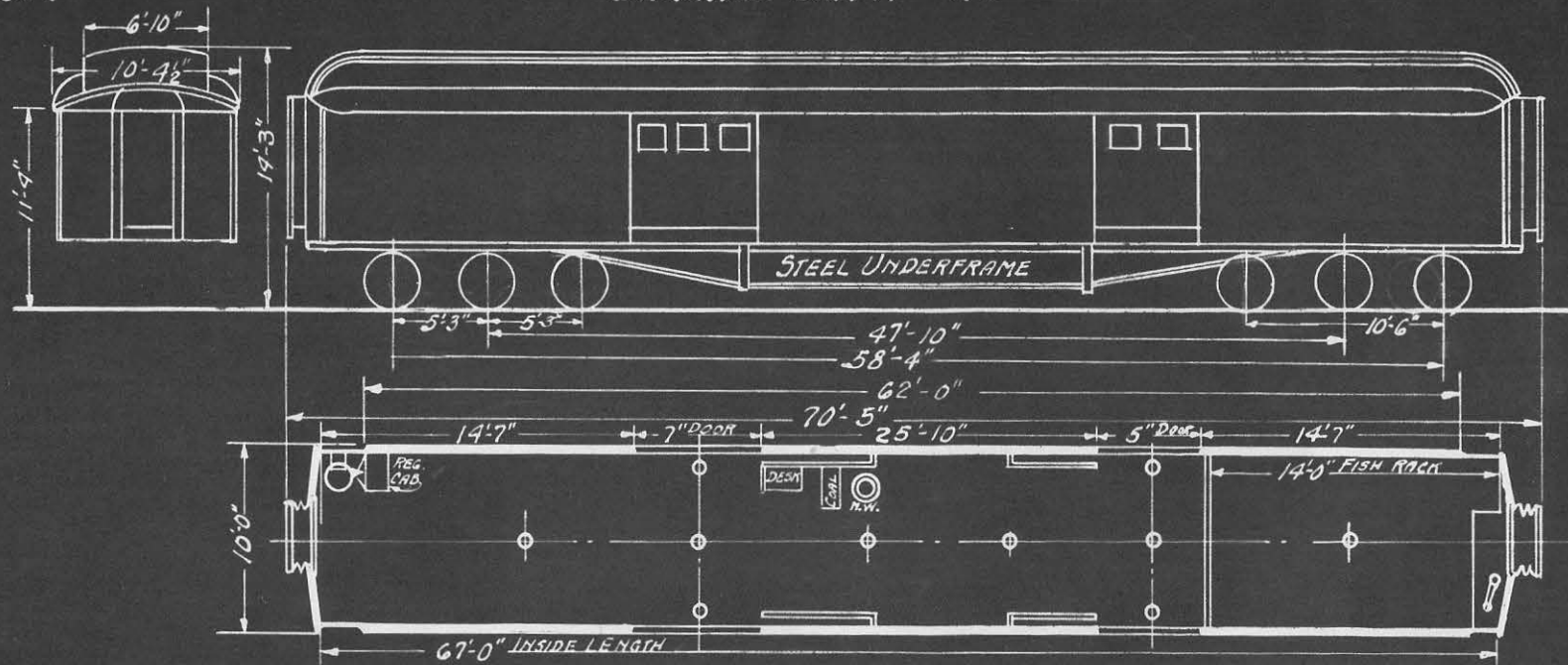

A.F.E. 50053

BE

5-4-40. 5-26-43

WEIGHT	113000 LBS.
LENGTH OVER FRAMING	62'-0"
" " BUFFERS	70'-5"
" INSIDE	67'-0"
WIDTH OVER CROWN MLDG.	10'-4 1/2"
" " FRAMING	10'-0"

TRUCK CENTERS	47'-10"
WHEEL BASE-TRUCKS	10'-6"
" - TOTAL	58'-4"
JOURNAL - SIZE	5 1/2" X 10"
KIND OF TRUCK	METAL FACED
WHEELS	36"

AIR BRAKE	18 CYL.	NEW YORK
" SIGNAL	"	"
HEATER	STOVE	NORTH WESTERN
CLASP BRAKE		
DRAFT GEAR		FARLOW - 6" X 8" SHANK
BUFFER		MINER FRICTION B-10-X

FINISH, EXTERIOR	STEEL SHEATH.
" INTERIOR	BEADED SHEATHING.
LIGHTING	ELECTRIC
COUPLER	LONG SHANK - 6 1/2" BUTT.

CAPACITY 65000



BUILT BY B. & S. CO. 1906 & 1908 (DINING CARS 1005 TO 1008); PULLMAN CO. - 1002 TO 1004 IN 1905.  
 STEEL UNDER., SHEATHING, & VEST. APPLIED 1922-23-24  
 REBUILT G.N.R.Y. - 1929

BAGGAGE CAR NOS. 420 TO 426.

37.

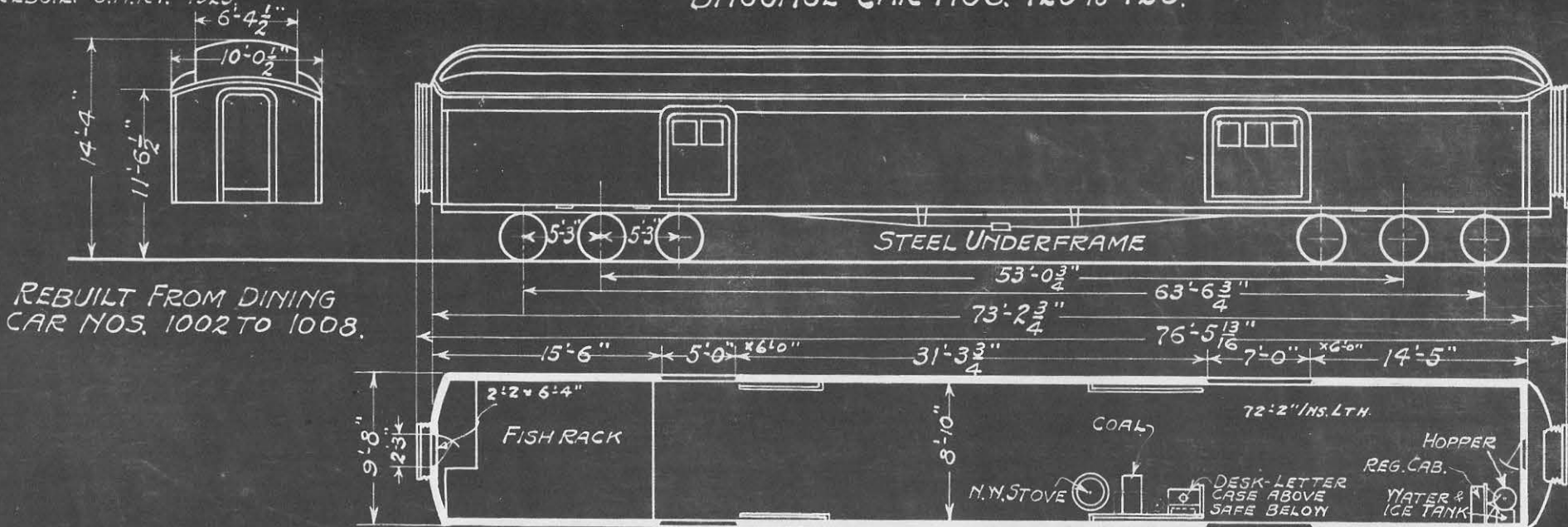

REBUILT FROM DINING CAR NOS. 1002 TO 1008.

A.F.E.-19750 & 39543.

WEIGHT	136,800	TRUCK CENTERS	53'-0 <sup>3</sup> / <sub>4</sub> "	AIR BRAKE	18" x 12" N.Y. CO.	FINISH-EXTERIOR-STEEL SHEATH
LENGTH OVER FRAMING	73'-2 <sup>3</sup> / <sub>4</sub> "	TOTAL WHEEL BASE	63'-6 <sup>3</sup> / <sub>4</sub> "	AIR SIGNAL	" " "	" INTERIOR-BEADED "
" " BUFFERS	76'-5 <sup>13</sup> / <sub>16</sub> "	TRUCK " "	10'-6"	HEATER	N.Y. STOVE	HEAD LINING-3-PLY POPLAR PAINT.
WIDTH " FRAMING	9'-8"	WHEELS	STEEL DIA. 36"	CLASP BRAKE	SIMPLEX	LIGHTING AXLE GEN. ELECTRIC.
" " CROWN MLDG.	10'-0 <sup>1</sup> / <sub>2</sub> "	KIND OF TRUCK	METAL FACED	VAPOR HEAT.		DRAFT GEAR MINER A-5-P.X.
CAPACITY	65,000 LBS.	JOURNAL SIZE	5' x 9"			COUPLER SHORT SHANK 9 <sup>1</sup> / <sub>8</sub> " BUTT.

12-2-29, Rev. G-1-30, REF. 6-B-31, Rev. 12-18-31, 5-26-43

BUILT BY B. & S. DAYTON, O. 1882.

BAGGAGE CAR No 427.

38

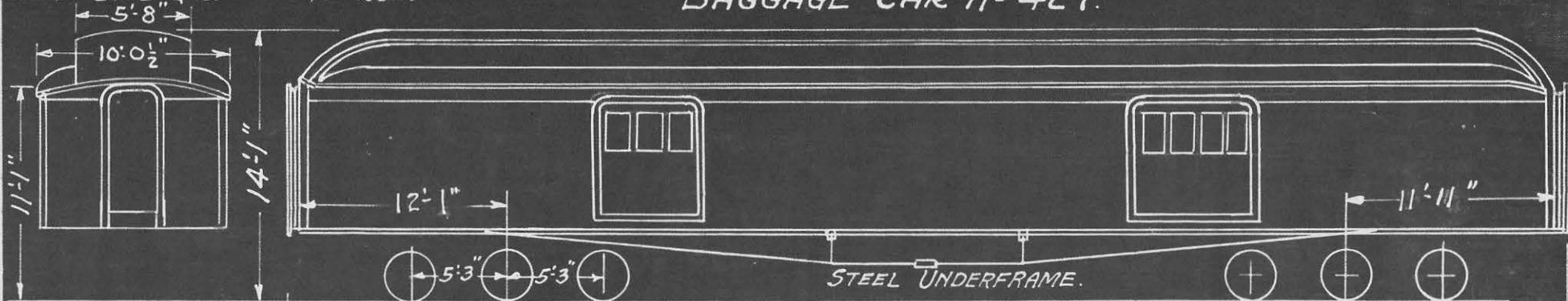

STEEL UNDERFRAME APPLIED 1924.  
FORMERLY A-24.  
TO BAGGAGE 1937.

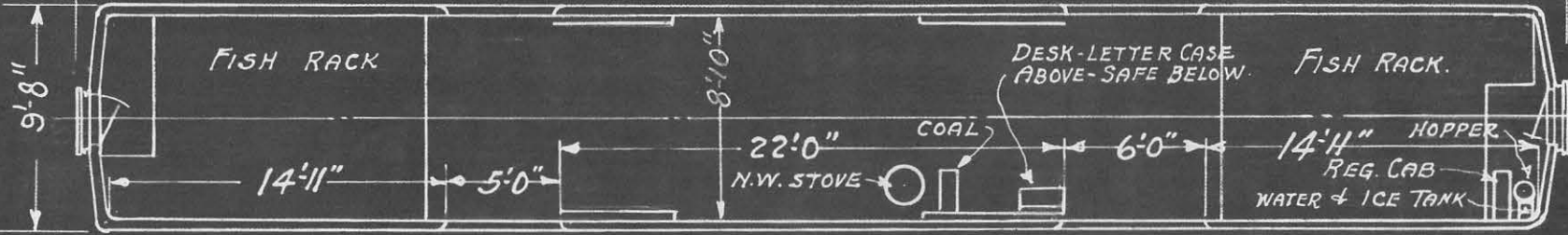

A.F.E. 27274, 50058.

BE

WEIGHT.	119 140 LBS.	TRUCK CENTERS	42'-9"	AIR BRAKES	18"×12" CYL. NEW YORK	FINISH, EXTERIOR-	STEEL SHEATHING
LENGTH OVER FRAMING	66'-9"	TOTAL WHEEL BASE	53'-3"	AIR SIGNAL	" "	" , INTERIOR-	FIR "
LENGTH OVER BUFFERS	68'-11 7/8"	TRUCK " "	10'-6"	HEATER	N.W. STOVE.	HEADLINING-	FIR "
WIDTH OVER FRAMING	9'-8"	WHEELS, STEEL	36" DIAM.	PIPING	FIN RADIATION.	LIGHTING	ELECTRIC
WIDTH OVER CROWN MLD'G	10'-0 1/2"	KIND OF TRUCK.	METAL FACED.			DRAFT GEAR	MINER.
		JOURNALS	5"×9"			COUPLER	SHORT SHANK 9 1/2" BUTT.

7-7-38. 5-26-43

BUILT BY G.N.RY 1910  
 REMODELED - BAGGAGE CAR 1940.  
 STEEL UNDERFRAME APPLIED 1925  
 STEEL SHEATH APPLIED 1928

# BAGGAGE CAR 428

39

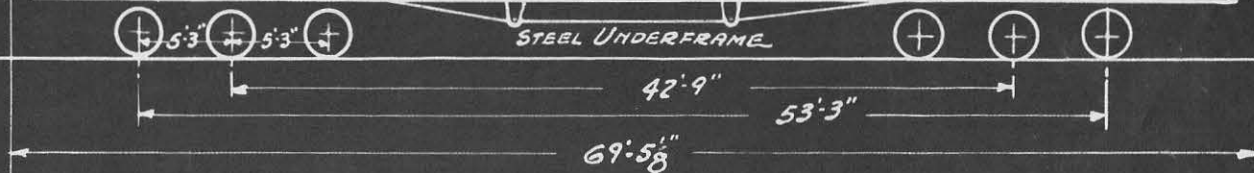
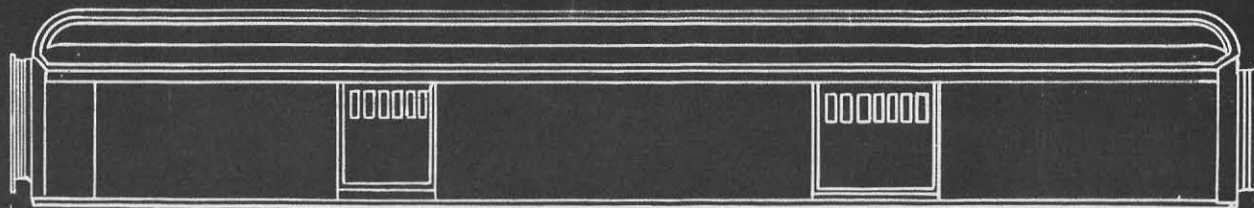
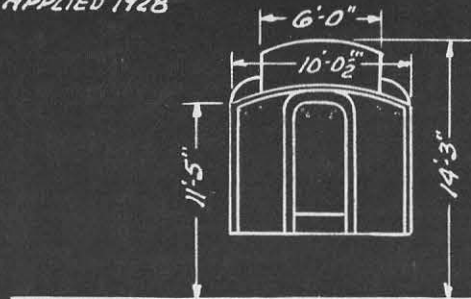

OLD. No. OFFICIAL CAR A-26.

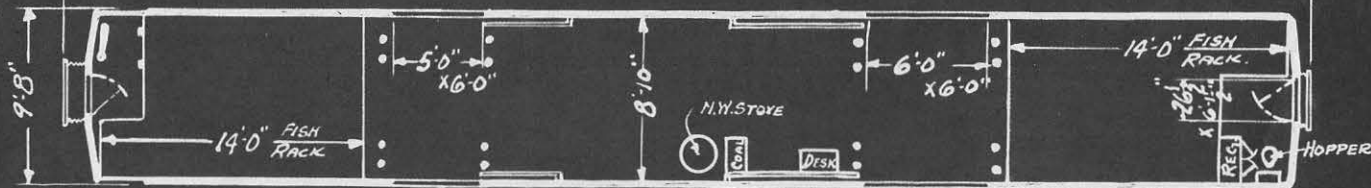

A.F.E. 28917, 35518 50058.

WEIGHT	120,200 LBS	TRUCK CENTERS	42'-9"	AIR BRAKE	14x12" CY. NEW YORK	FINISH EXTERIOR	STEEL SHEATHING
LENGTH OVER FRAMING		WHEEL BASE TRUCK	10'-6"	AIR SIGNAL	" "	" INTERIOR	WOOD
" " BUFFERS	6'9 1/8"	" " TOTAL	53'-3"	HEATER	N.Y. STOVE	HEADLINING	WOOD
WIDTH OVER FRAMING	9'-8"	WHEELS	36" DIA.	HEATER PIPING	YAPOR	LIGHT	ELECTRIC
" " CROWN MLDG.	10'-0 1/2"	KIND OF TRUCK	METAL FACED			DRAFT GEAR	MINER
WIDTH INSIDE	8'-10"	JOURNALS SIZE	5'x9"			COUPLER SWIVEL BUTT	AAR E HEAD.
LENGTH	65'-8 1/2"						
CAPY	50,000 LBS						

11-28-40 5-26-43

BE



BUILT BY B&S 1893  
 REMODEL G.H.RY BAGGAGE CAR 1940  
 STEEL UNDERFRAME APPLIED 1927

# BAGGAGE CAR 429

40

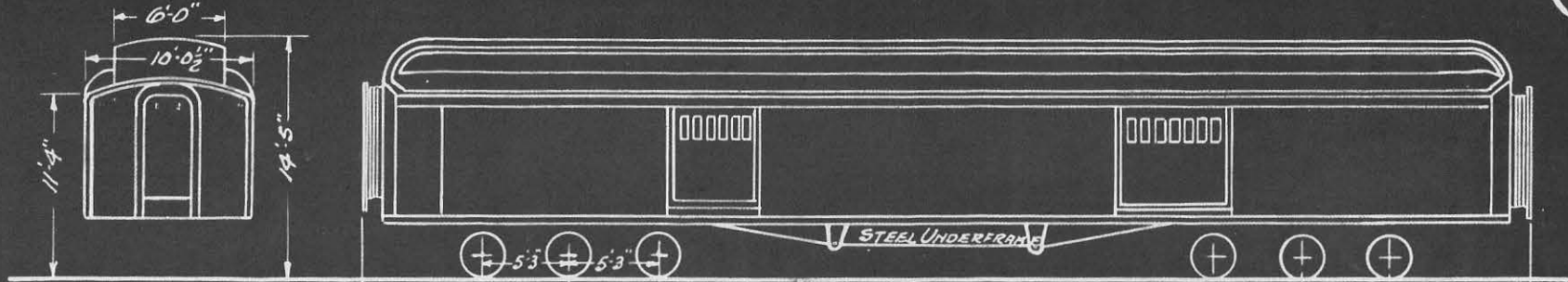

OLD NO. OFFICIAL CAR A-12

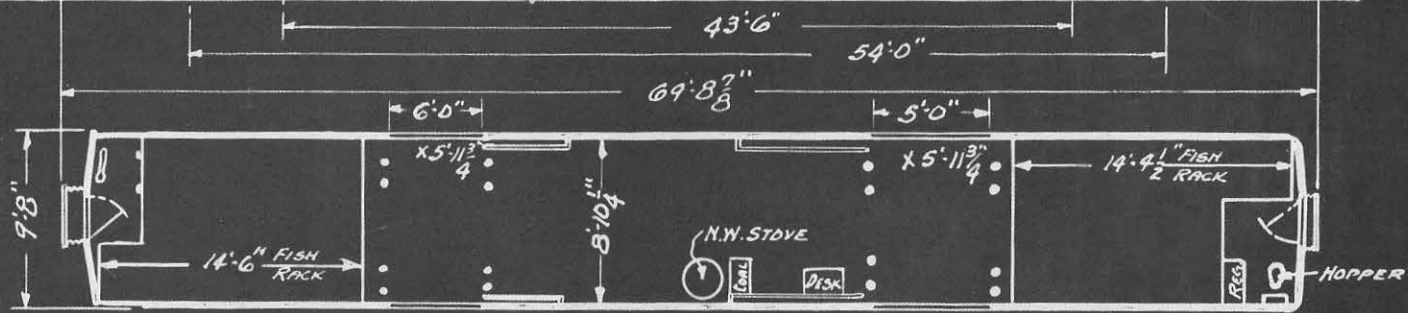

A.F.E. 26543, 33949, 50058, 50059

WEIGHT	129,100 LBS.	TRUCK CENTERS	43'-6"	AIR BRAKE	CYL 18" x 12.	FINISH EXTERIOR	GROOVED SHEATHING
LENGTH OVER FRAMING		WHEEL BASE TRUCK	10'-6"	AIR SIGNAL		" INTERIOR	WOOD
" " BUFFERS	69'-8 7/8"	WHEEL BASE TOTAL	54'-0"	HEATER	H.W. STOVE	HEADLINING	WOOD
WIDTH OVER FRAMING	9'-8"	WHEELS	STEEL 36" DIA.	VAPOR HEAT.		LIGHTING	ELECTRIC
" " CROWN MLDG.	10'-0 1/2"	JOURNALS	SIZE 5" x 9"			DRAFT GEAR	MINER
INSIDE WIDTH	8'-10 1/4"	KIND OF TRUCK	METAL FACED			COUPLER	SHORT SHANK 9 1/2" BUTT.
INSIDE LENGTH	66'-7 1/2"						
CAPY	65,000 LBS.						

11-28-40 6-24-42 5-26-43

BUILT BY B. & O. 1893. REMODELED G. N. Ry 1906  
 STEEL UNDERFRAME APPLIED 1924 & CHANGED TO BUSINESS CAR  
 CHANGED TO BAGG. CAR 1930.

# BAGGAGE CAR NO 430.

41

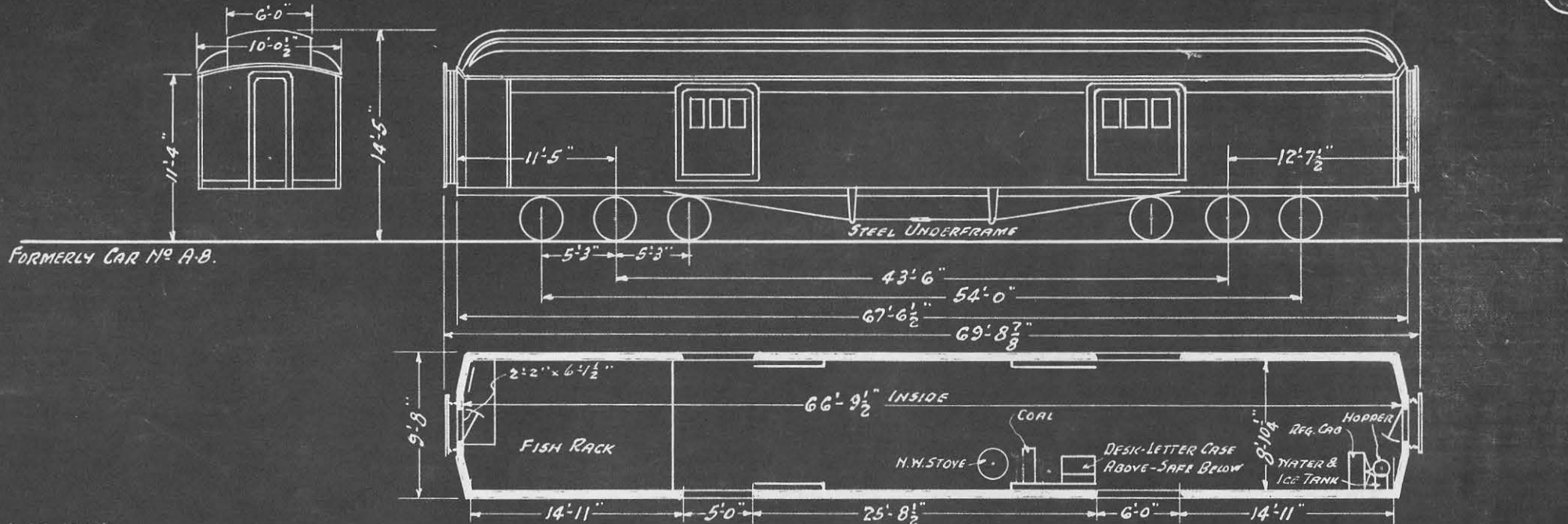

A.F.E. 41340.

WEIGHT	125200 LBS.	TRUCK CENTERS	43'-6"	AIR BRAKE	18" x 12" CYL.	FINISH EXTERIOR	STEEL SHEATHING
LENGTH OVER FRAMING	67'-6 1/2"	WHEELBASE TOTAL	54'-0"	HEATING	1-N.Y. STOVE	" INTERIOR	BEADED "
" " BUFFERS	69'-8 7/8"	" " TRUCK	10'-6"	HEAT PIPING	2 1/2" DIA.	HEAD LINING	3-PLY POPLAR PAINTED
" " FRAMING	9'-8"	WHEELS	ROLLED STEEL	VAPOR HEAT		LIGHTING	AXLE GEN. ELECTRIC.
" " CROSSIN MLDG.	10'-0 1/2"	JOURNALS	SIZE			DRAFT GEAR	MINER A-5-P-X
CAPACITY	65000 LBS.	KIND OF TRUCK	METAL FACED.			COUPLER	5x7" "E" SWIV. BUTT.

2-8-36. Rev. 6-1-30. Rev. 12-18-31. 5-26-43

2-8-30 Rev. 6-1-30. Ref. 6-8-31. Rev. 12-18-31. Rev. 9-9-35. REV. 8-2-38, 5-26-40

BUILT BY B.&O. 1911, 1909.  
 STEEL UNDERFRAME, SHEATHING & VESTIBULE APPLIED 1923.  
 REBUILT G.N.R.Y 1930, 1935.

# BAGGAGE CAR Nos 432 TO 436.

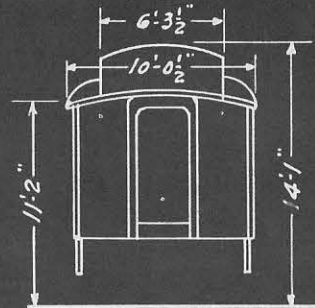

REBUILT FROM OBS. CAR  
 Nos ~~1109~~, 1111, 1112, 1115,  
 1105, 1108.

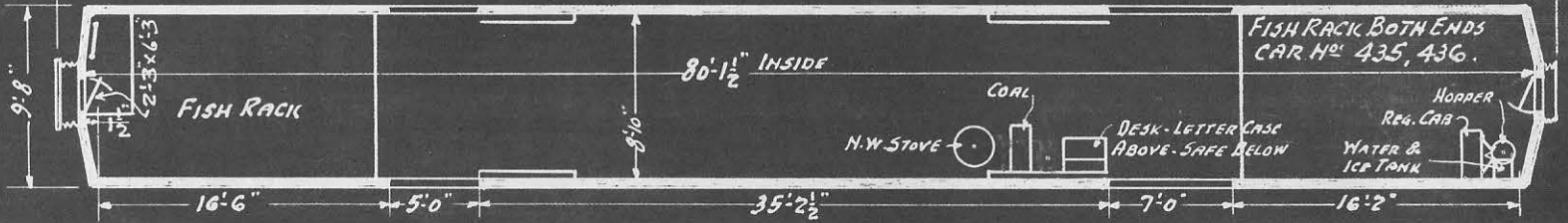
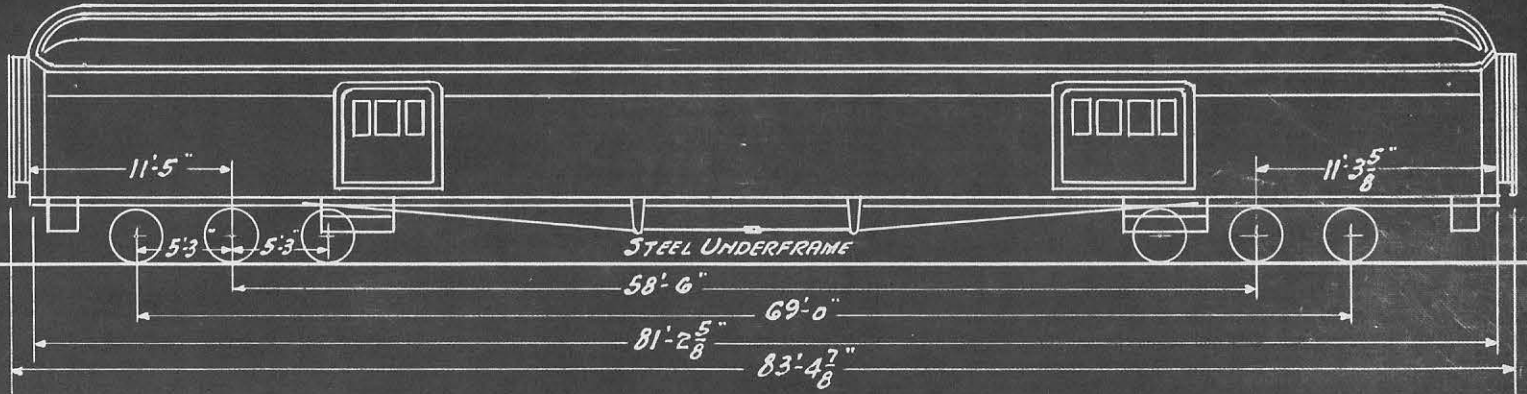

A.F.F. 20785, 41340, 48354.

WEIGHT	151600 LBS.
LENGTH OVER FRAMING	81'-2 <sup>5</sup> / <sub>8</sub> "
" BUFFERS	83'-4 <sup>7</sup> / <sub>8</sub> "
WIDTH " FRAMING	9'-8"
" " CROWN M'LG.	10'-0 <sup>1</sup> / <sub>2</sub> "
CAPACITY	65000 LBS.

TRUCK CENTERS	58'-6"
WHEEL BASE - TRUCK	10'-6"
" " - TOTAL	69'-0"
WHEELS	ROLLED STEEL 36" DIA.
KIND OF TRUCK	METAL FACED
JOURNALS	SIZE 5 <sup>1</sup> / <sub>2</sub> x 10"

AIR BRAKE	2-16 x 12 CYL.	NEW YORK
HEAT	1-N.W. STOVE	
HEAT PIPING	2 <sup>1</sup> / <sub>2</sub> "	462 FT.
CLASP BRAKE		SIMPLEX
VAPOR HEAT.		

FINISH EXTERIOR	STEEL SHEATHING.
" INTERIOR	BEADED "
HEAD LINING	3-PLY POPLAR PAINTED
LIGHTING	AXLE GEN. ELECTRIC.
DRAFT GEAR	MINER A-5-P-X
COUPLER	SHORT SHANK 9 <sup>1</sup> / <sub>8</sub> " BUTT.

BE



BUILT BY B & S. DAYTON 1893  
 REMODELED BAGGAGE CAR 1940.  
 UNDERFRAME & WHEELS APPLIED 1924  
 STEEL SHEATHING APPLIED 1925

# BAGGAGE CAR 437

43

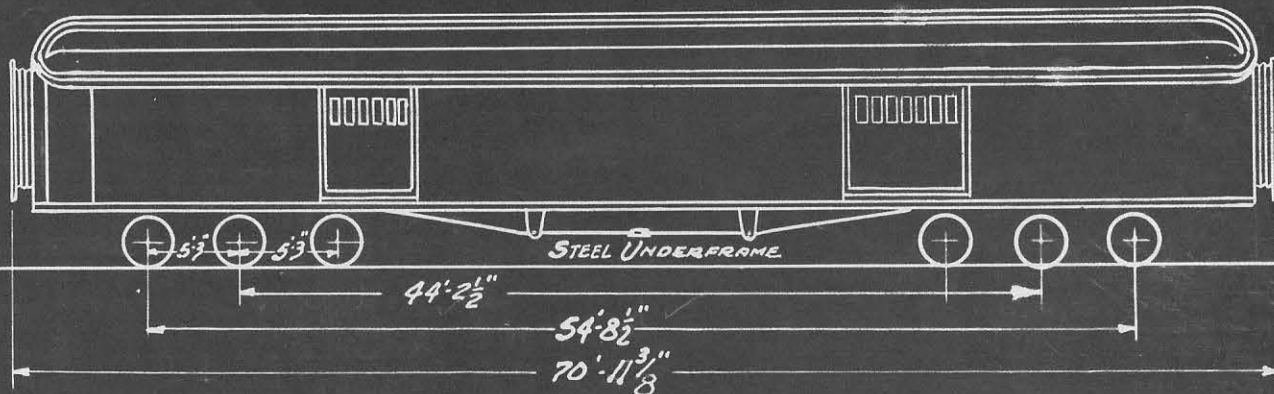
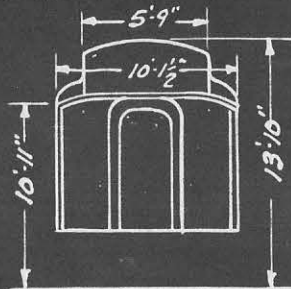

OLD NO. OFFICIAL CAR A-29.

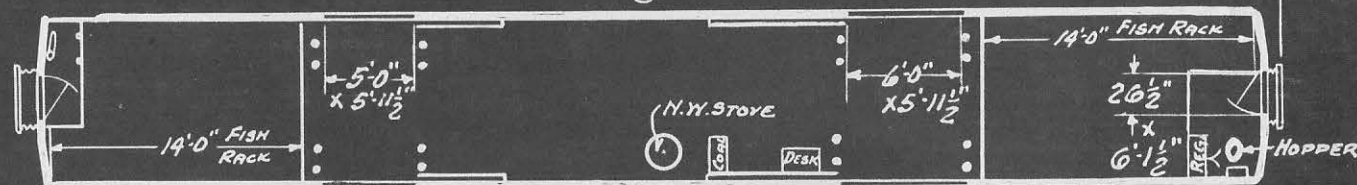

A.F.E. 25807 50058.

WEIGHT	124,100 LBS.
LENGTH OVER FRAME	
"    BUFFERS	70'-11 3/8"
WIDTH " FRAME	9'-9"
"    CROWN MLDG.	10'-1 1/2"
WIDTH INSIDE	8'-10 1/2"
LENGTH "	67'-1 1/2"
CAPY	50,000 LBS.

BOLSTER CENTERS	44'-2 1/2"
TOTAL WHEEL BASE	54'-8 1/2"
TRUCK " "	10'-6"
WHEELS - ROLLED STEEL	36 DIA.
JOURNALS	5"x9"
KIND OF TRUCK	CAST STEEL

AIR BRAKE	NEW YORK.
" " SIGNAL	" "
" " COMPENSATING VALVE	" "
N.-Y. STOVE	
VAPOR HEAT.	

OUTSIDE FINISH	STEEL SHEATHING
INSIDE " "	WOOD
HEAD LINING	WOOD
LIGHTING	ELECTRIC
DRAFT GEAR	MINER
COUPLER	SHORT SHANK-SWIVEL BUTT.

11-28-40 5-26-43

BUILT BY B&O. 1911  
 STEEL UNDERFRAME SHEATHING 1927  
 REMODELED BAGGAGE CAR 1940

# BAGGAGE CAR 438

44

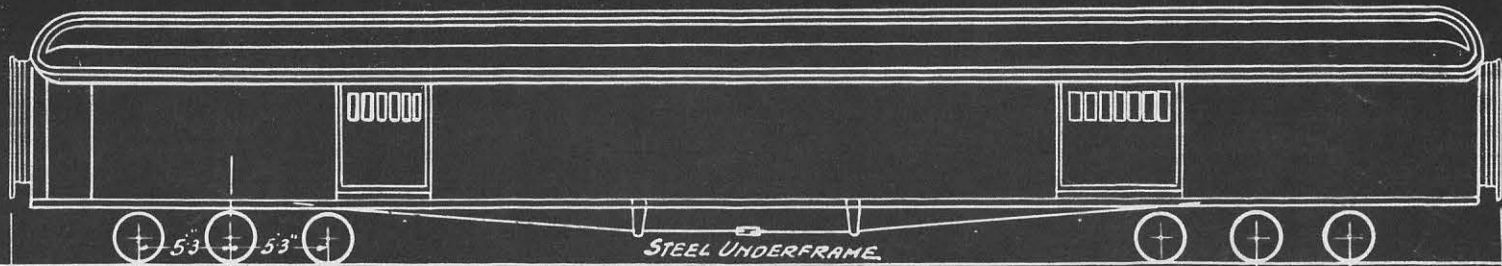
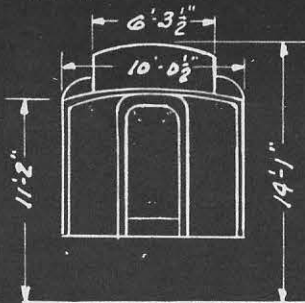

OLD NO. PARLOR OBS. 1116

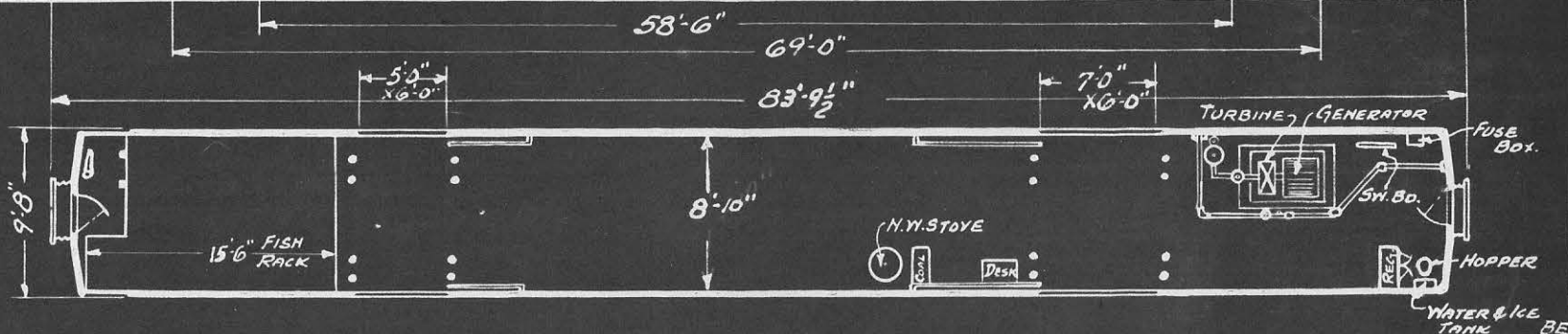

A.F.E. 20785, 28517, 50059

WEIGHT	160,100 #
LENGTH OVER FRAMING	
" " BUFFERS	83'9 1/2"
WIDTH " FRAMING	9'8"
" " CROWN MLDG.	10'0 1/2"
WIDTH INSIDE	8'10"
LENGTH "	79'9"
CAPY	50,000 LBS

TRUCK CENTERS	58'6"
WHEEL BASE - TRUCK	10'6"
" " TOTAL	69'0"
WHEELS STEEL TIRED	36" DIA.
KIND OF TRUCK	METAL FACED
JOURNALS SIZE	5 1/2" X 10"

AIR BRAKE	2-16" X 12" CYL. NEW YORK
AIR SIGNAL	" "
HEATER	N.Y. STOVE
HEATER PIPING	VAPOR FIN RAD.
AXLE GEN	4 KW.
CLASP BRAKE	SIMPLEX
BATTERY	21 PLATE

FINISH EXTERIOR	STEEL SHEATHING
" INTERIOR	WOOD
HEADLINING	STEEL
LIGHTING	ELECTRIC
DRAFT GEAR	MINER
COUPLER	SHORT SHANK - SWIVEL TYPE
STEAM TURBO GEN.	CURTISS TURBINE 40V. 250AMP.

11-28-40 5-26-43

BUILT BY A.C.F.CO. 1904  
STEEL UNDERFRAME ADDED 1940

# BAGGAGE CAR 439

45

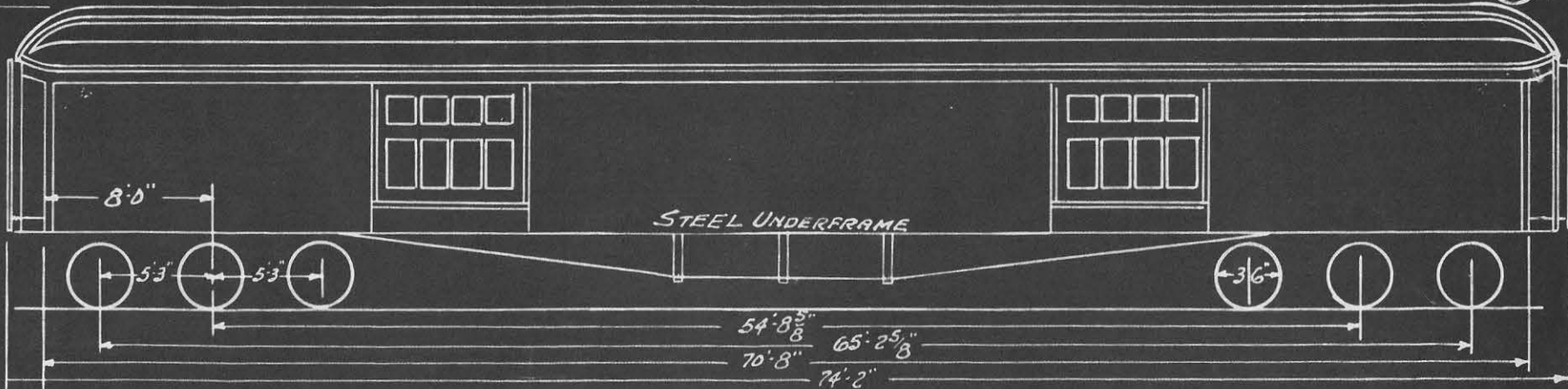
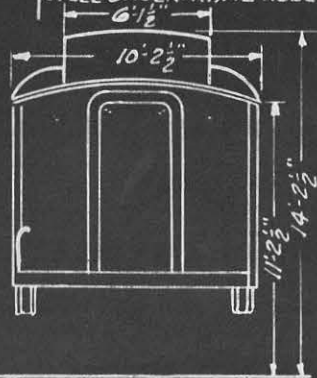

FORMERLY BAGGAGE  
CAR 480.

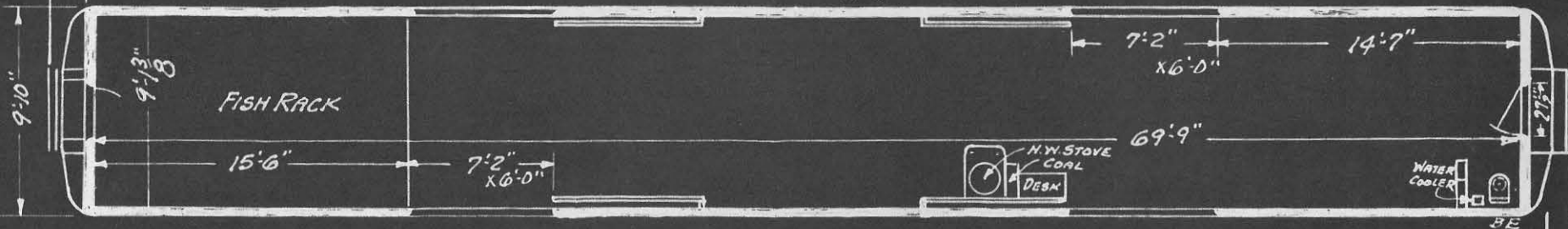

11-28-40 5-26-49

WEIGHT	128,600 LBS	TRUCK CENTERS	54' 8 5/8"	AIR BRAKE	CYL. 14 x 12"	FINISH EXTERIOR	GROOVED SHEATHING
LENGTH OVER FRAMING	70' 8"	TOTAL WHEEL BASE	65' 2 5/8"	" SIGNAL	NEW YORK	" INTERIOR	BEADED LINING
" " BUFFERS	74' 2"	TRUCK " "	10' 6"	HEATER	N.Y. STOVE	LIGHTING	ELECTRIC
WIDTH " FRAMING	9' 10"	WHEELS	STEEL 36" DIA.	HEATING	VAPOR SYSTEM	DRAFT GEAR	MINER
" " CROWN MOLD'G.	10' 2 1/2"	TRUCK	METAL FACED			COUPLER	SWIVEL TYPE 5X7
CAPY	50,000 LBS	JOURNALS	5" x 9"				



BUILT BY B. & O. CO. 1909 DINING CAR 1010 TO 1016. 1910-1017 TO 1021, 1911-1022 TO 1029.  
 STEEL UNDERFRAMES, SHEATHING & VESTIBULES APPLIED 1922, 1923, 1924.  
 REBUILT TO BAGG. CARS. 1931, 1932, 1933, 1934, 1935, 1936.

# BAGGAGE CAR Nos 440 TO 458.

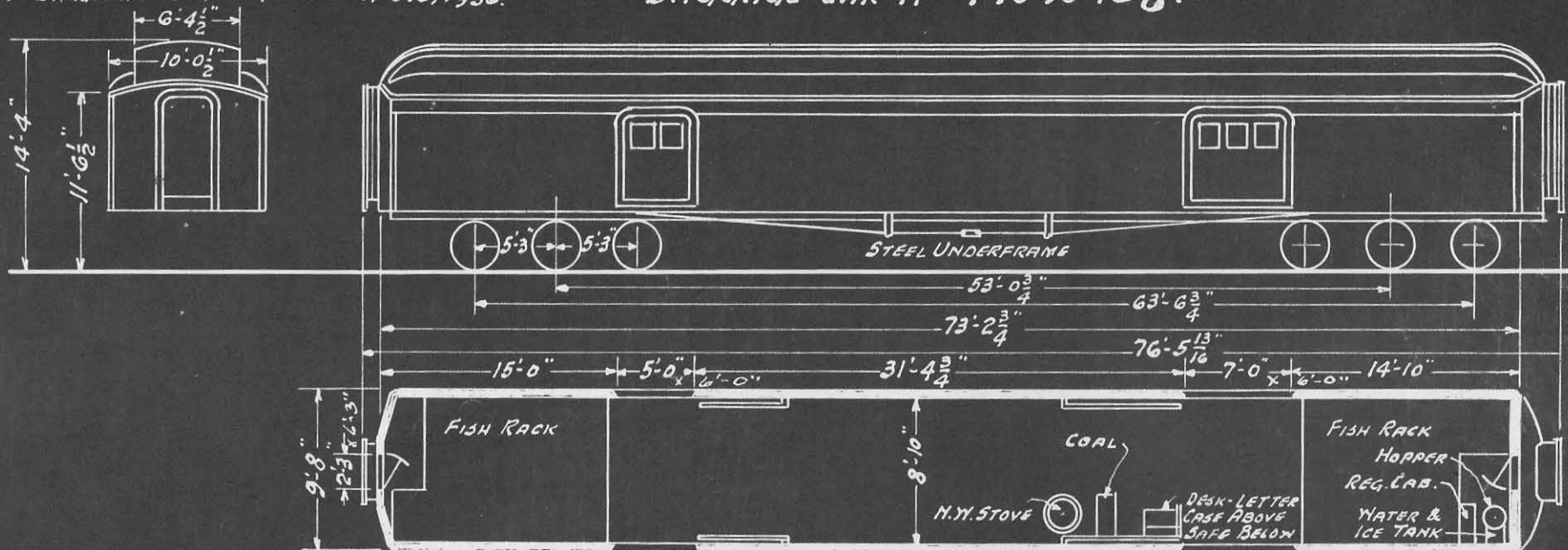

A.F.E. 19750, 44207, 48354.

BE

WEIGHT	14200 LBS.	TRUCK CENTERS	53'-0 3/4"	AIR BRAKE	1-18" x 12" CYL	FINISH-EXTERIOR	STEEL SHEATHING.
LENGTH OVER FRAMING	73'-2 3/4"	TOTAL WHEEL BASE	63'-6 3/4"	VAPOR HEAT		"-INTERIOR	BEADED "
" " BUFFERS	76'-5 13/16"	TRUCK " "	10'-6"	HEATER	N.Y. STOVE	HEAD LINING	3-PLY POPLAR PAINTED.
WIDTH " FRAMING	9'-8"	WHEELS	STEEL 36" DIA.	CLASP BRAKE	SIMPLEX.	LIGHTING	AXLE GEN. ELECTRIC.
" " CROWN MLDG.	10'-0 1/2"	KIND OF TRUCK	METAL FACED.			DRAFT GEAR	MINER A-5-P-X.
CAPACITY	6500 LBS.	JOURNAL SIZE	5" x 9"			COUPLER	1-SHORT SHANK 9 1/2" BUTT.
							1 LONG SHANK "

REV. 10-14-38. REV. 11-20-40. 5-26-43. 10-21-31. REV. 12-18-31. REV. 9-30-33. REV. 9-9-35. REV. 7-28-36. REV. 8-4-36.

BUILT BY B&S 1906.  
 STEEL UNDERFRAM SHEATHING & VEST. APPLIED 1923.  
 INT. RE-ARRANGED 1928. BAGGAGE CAR 1936.

# BAGGAGE CAR NO. 460,461

47

2-5-38, REV. 10-14-38, REV. 11-20-40, 5-26-43

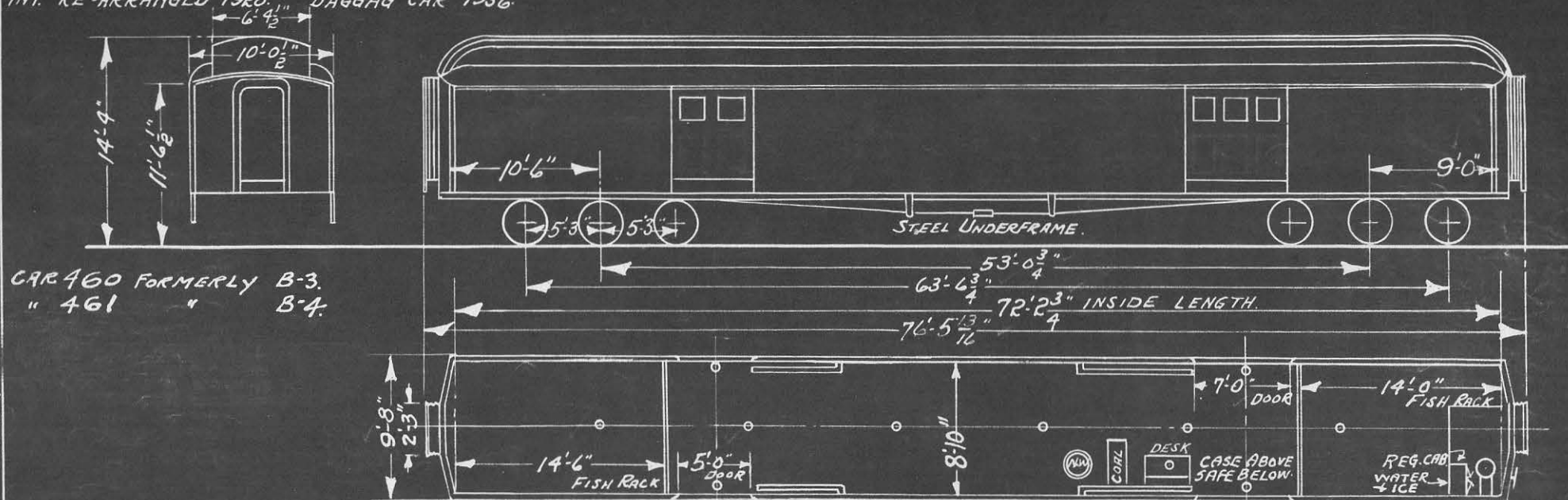

CAR 460 FORMERLY B-3.  
 " 461 " B-4.

A.F.E. 50058

BE

WEIGHT	135,000 LBS.	TRUCK CENTERS	53'-0 <sup>3</sup> / <sub>4</sub> "	AIR BRAKE	18" x 12" CYL.	FINISH EXTERIOR	STEEL SHEATHING
LENGTH OVER FRAMING	76'-5 <sup>13</sup> / <sub>16</sub> "	" WHEELBASE	10'-6"	HEATER STOVE	NORTH WESTERN	" INTERIOR	WOOD LINING
" " BUFFERS	9'-8"	WHEELBASE TOTAL	63'-6 <sup>3</sup> / <sub>4</sub> "	CLASP BRAKE	SIMPLEX	LIGHTING	OIL & ELECTRIC
WIDTH " FRAMING	9'-8"	WHEELS	STEEL DIA. 36"	VAPOR HEAT	FIN RADIATION	AXLE GENERATOR	3 KW.
" " CROWN MOULDING	10'-0 <sup>1</sup> / <sub>2</sub> "	JOURNALS	SIZE 5" x 9"	DINING CAR	PANELED CEILING RETAINED	DRAFT GEAR	MINER
HEIGHT INSIDE	9'-1 <sup>3</sup> / <sub>4</sub> "	KIND OF TRUCK	METAL FACED	ON CAR 460 ONLY.		COUPLER	SHORT SHANK 9 <sup>1</sup> / <sub>8</sub> " BUTT

3754

BUILT BY A.C.&F.Co. 468-1906, 474-1910.  
 STEEL UNDERFRAME APPLIED & INTERIOR REARRANGED 1928.

# BAGGAGE CAR Nos 468, 474.

49

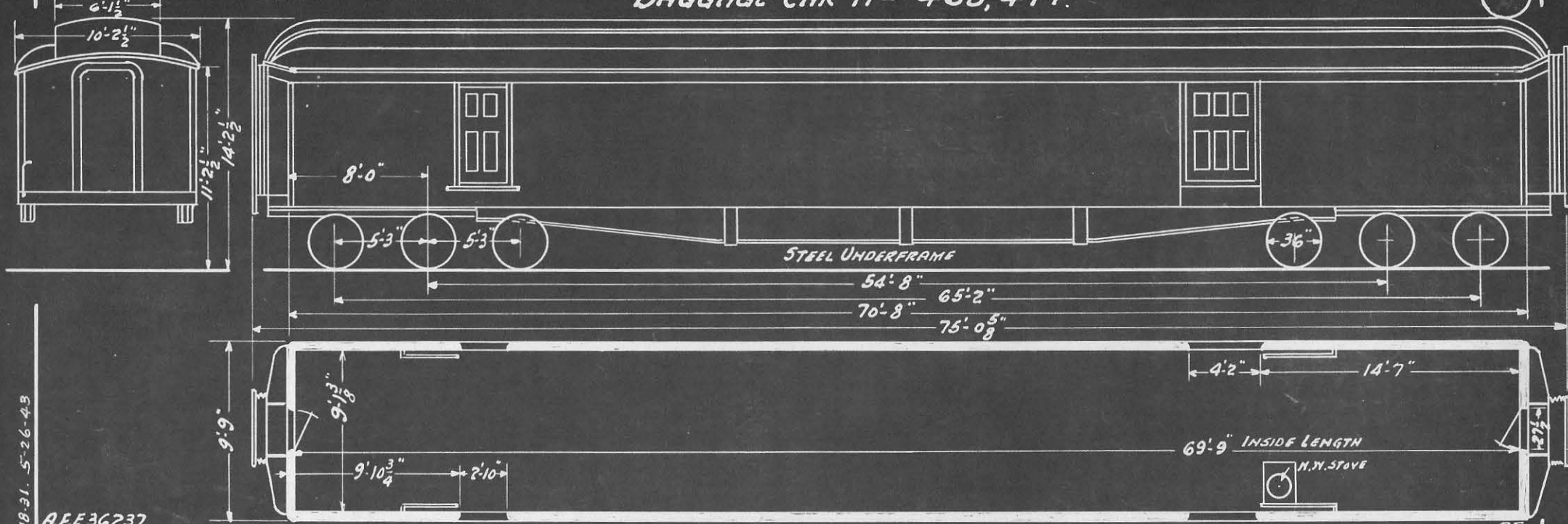

A.P.E36237.

WEIGHT	124200 LBS.	TRUCK CENTERS	54'-8"	AIR BRAKE	2-14" x 12" CYL.	FINISH-EXTERIOR	GROOVED SHEATHING.
LENGTH OVER FRAMING	70'-8"	TOTAL WHEEL BASE	65'-2"	" SIGNAL		" -INTERIOR	BEADED LINING
" " BUFFERS	75'-0 5/8"	TRUCK " "	10'-6"	HEATER	N.Y. STOVE	LIGHTING	ELECTRIC.
WIDTH " FRAMING	9'-9"	WHEELS	STEEL 36" DIA.	DIRECT STEAM		DRAFT GEAR	MINER A-5. P. X.
" " CROWN MOLDG.	10'-2 1/2"	KIND OF TRUCK	METAL FACED.	HEAT PIPING	2"	COUPLER	SHORT SHANK 9 1/8" BUTT.
CAPACITY	50000 LBS.	JOURNALS	SIZE 5" x 9"				

5-7-31, Rev. 12-18-31, 5-26-43



BUILT BY A. C. & F. CO. 469-1926.  
 STEEL UNDERFRAME APPLIED & INTERIOR REARRANGED 1928.

# BAGGAGE CAR NO. 469.

49

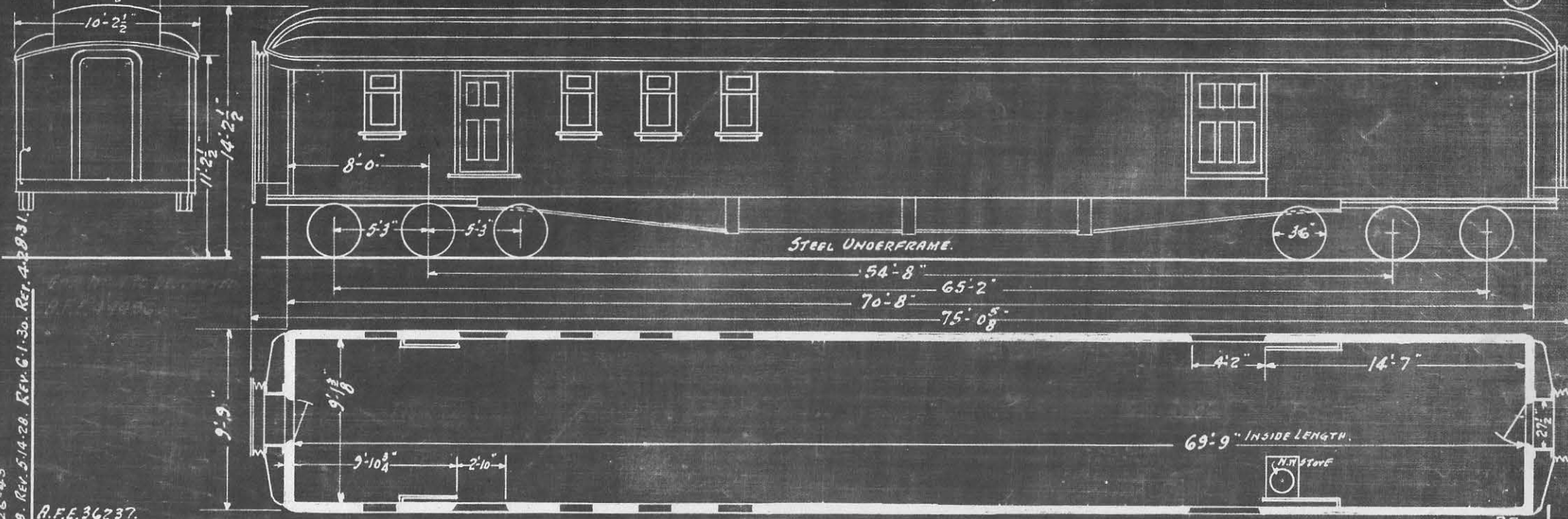

A.F.E. 36237.

WEIGHT	124200 LBS.	TRUCK CENTERS	54'-8"	AIR BRAKE	2-14" x 12" CYL.	FINISH-EXTERIOR	GROOVED SHEATHING
LENGTH OVER FRAMING	70'-8"	TOTAL WHEEL BASE	65'-2"	" SIGNAL		" INTERIOR	BEADED LINING
" " BUFFERS	75'-0 5/8"	TRUCK " "	10'-6"	HEATER	N.Y. STOVE	LIGHTING	ELECTRIC.
WIDTH " FRAMING	9'-9"	WHEELS	STEEL 36" DIA.	DIRECT STEAM		DRAFT GEAR	MINER A-5-P-X
" " CROWN MOLDS.	10'-2 1/2"	KIND OF TRUCK	METAL FACED.	HEAT PIPING	2"	COUPLER	SHORT SHANK 9 1/8" BUTT.
CAPACITY	50000 LBS.	JOURNALS	SIZE 5" x 9"				

REV. 12-18-31. 5-26-43  
 3-1-28. REV. 5-5-28. REV. 5-14-28. REV. 6-1-30. REV. 4-28-31.

BUILT BY B. & S. 1890

# PASSENGER & BAGGAGE CAR No 500.

53.

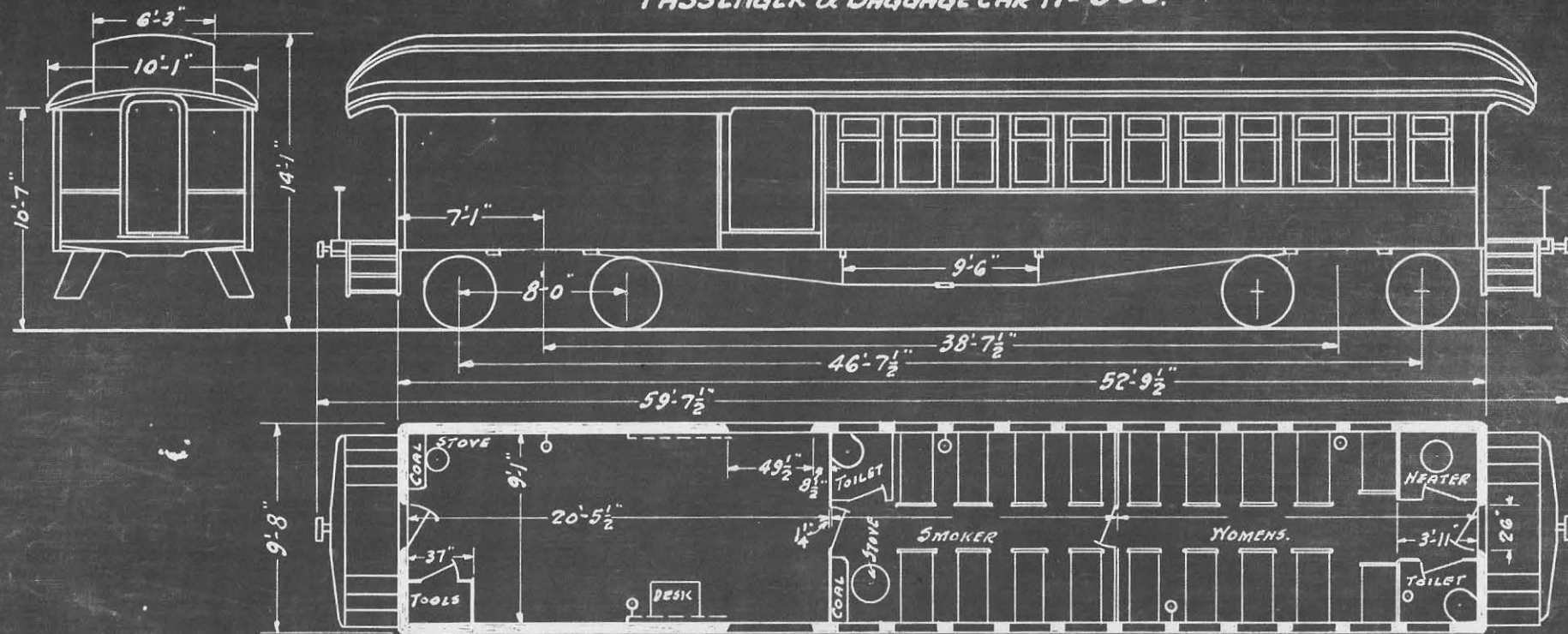

6-1-25. REV. 3-1-26. REV. 6-1-30. 5-26-43

WEIGHT	61200 LBS.	TRUCK CENTERS	38'-7 1/2"	AIR BRAKE	10" x 12" CYL.	FINISH, EXTERIOR	GROOVED SHEATHING
LENGTH OVER FRAMING	52'-9 1/2"	WHEEL BASE - TRUCK	8'-0"	AIR SIGNAL		" INTERIOR	PASS. OAK
" " BUFFERS	59'-7 1/2"	" - TOTAL	46'-7 1/2"	HEATER	CABOOSE STOVE IN BAGG.	BAGG. GROOVED SHEATHING	
WIDTH OVER FRAMING	9'-8"	WHEELS	STEEL 33" DIA.	1-N.Y. STOVE & BAKER HEATER IN PASS.		HEAD LINING	MAPLE
" " CROWN MLDG.	10'-1"	KIND OF TRUCK	METAL FACED.	HEATER PIPING	1/4" 384 FT.	LIGHTING	OIL
SEATING CAPACITY	36.	JOURNALS	SIZE 4 1/4 x 8"	DRAFT GEAR	3-SPRING.	LAMPS	PASS. 4-1-LIGHTS
CAPACITY	20000 LBS.			COUPLER	LONG SHANK 6 1/2" BUTT.		BAGG. 2-1- "

BUILT BY BARNEY & SMITH 1879

PASSENGER & BAGGAGE CAR NO. 506.

54

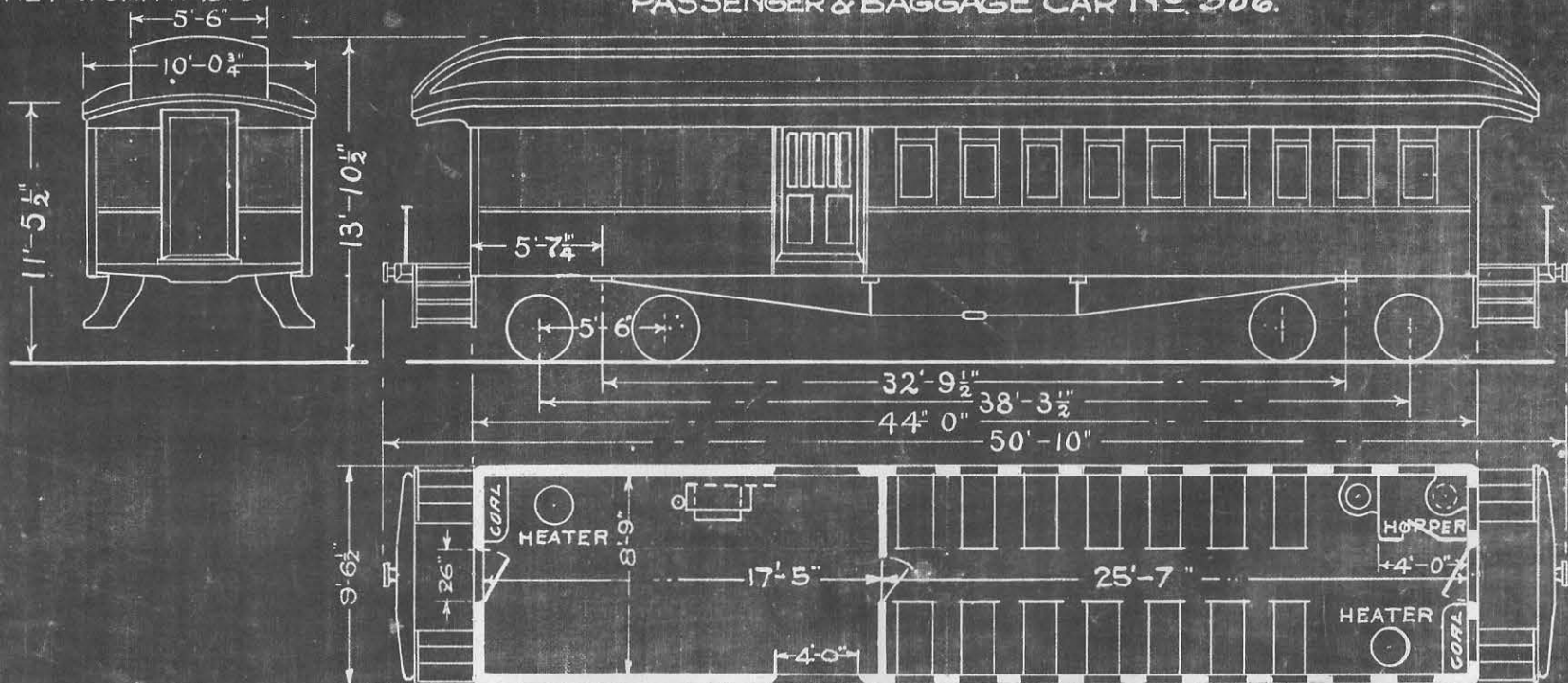

THIS CAR EQUIPPED WITH C.S. H SECTION BODY BOLSTER & I BEAM NEEDLE BEAM A.F.E. 26925.

CA

WEIGHT,	LBS, 50,900.
LENGTH OVER FRAMING,	44'-0"
LENGTH OVER BUFFERS,	50'-10"
WIDTH OVER FRAMING,	9'-6 1/2"
WIDTH OVER CROWN MILDG,	10'-0 3/4"
SEATING CAPACITY,	28.
CAPACITY	20000 LBS.

TRANSOM CENTERS,	32'-9 1/2"
TOTAL WHEEL BASE,	38'-3 1/2"
TRUCK WHEEL BASE,	5'-6"
WHEELS, -STEEL TIRED, -DIAM,-	33"
KIND OF TRUCK	WOOD.
JOURNALS,	4 1/4" X 8"

AIR BRAKES,	10" X 12" CYL.
AIR SIGNAL,	
HEATER, (MAKER) "SPEAR"	
-TWO SPEAR STOVES.	
HEATER PIPING	2" 166 FT.
WATER SYSTEM	

FINISH, EXTERIOR,-	GROOVED SHEATHING.
FINISH, INTERIOR,-	A&H AND WALNUT,
HEAD LINING,-	CLOTH.
LIGHTING,-	OIL,
DRAFT GEAR	3-SPRING.
COUPLER	LONG SHANK- 6 1/2" BUTT.

Rev. 5-1-24. Rev. 12-15-24. Rev. 3-1-26. Rev. 6-1-30. 5-26-43



BUILT BY BARNEY & SMITH, 1889.

PASSENGER AND BAGGAGE CAR- No. 514.

55

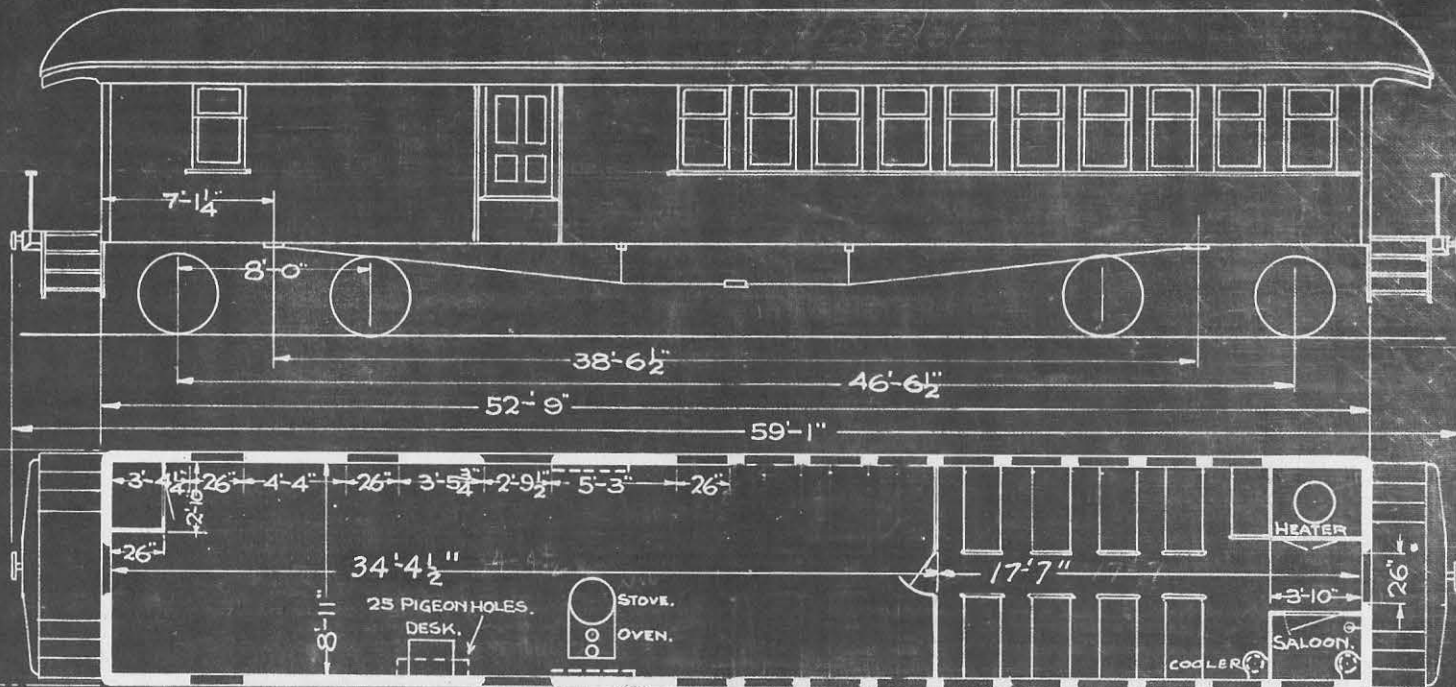
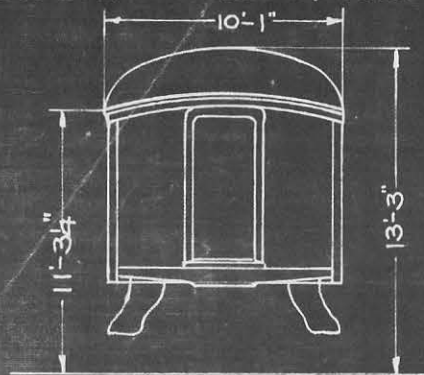

Old No 427.

REV. 5-1-24, REV. 3-1-26, REV. 6-1-30, 5-26-43

WEIGHT, LBS. 64500  
 LENGTH OVER FRAMING, 52'-9"  
 LENGTH OVER BUFFERS, 59'-1"  
 WIDTH OVER FRAMING, 9'-8"  
 WIDTH OVER CROWN MLDG, 10'-1"  
 SEATING CAPACITY, 18.  
 CAPACITY LBS 20000.

TRANSOM CENTERS, 38'-6 1/2"  
 TOTAL WHEEL BASE, 46'-6 1/2"  
 TRUCK WHEEL BASE, 8'-0"  
 WHEELS, - STEEL - DIA. 36"  
 KIND OF TRUCK METAL FACED.  
 JOURNALS, SIZE, 4 1/2 X 8

AIR BRAKE, 10"x12" CYL.  
 AIR SIGNAL,  
 HEATER, (MAKER) BAKER, SINGLE COIL.  
 G. H. STOVE.  
 HEATER PIPING, 1 1/2" - 384. FT.  
 WATER SYSTEM.

FINISH, EXTERIOR, GROOVED SHEATHING.  
 FINISH, INTERIOR, (PASS- ANTIQUE OAK.  
 (MAIL- BEADED SHEATHING.  
 HEAD LINING, (PASS- MAPLE.  
 (BAGG- BEADED CEILING.  
 LIGHTING, OIL.  
 DRAFT GEAR 3-SPRING  
 COUPLER LONG SHANK 6 1/2 BUTT.

REV. 7-27-50. 12-15-41. 5-26-43.  
 REV. 6-1-30 REF. 12-18-31. REV. 5-15-36. REV. 1-15-37. REV. 5-28-38. REV. 9-7-38.  
 FORMERLY 2ND CL. COACH NOS. 3037 TO 3059. REV. 5-1-24. REV. 6-1-25. REV. 3-1-26.

BUILT BY BARNEY & SMITH 1883  
 REMODELED G.M.R.V. 1917.

PASSENGER & BAGGAGE CAR NOS. 518, 519, 521, 526

56

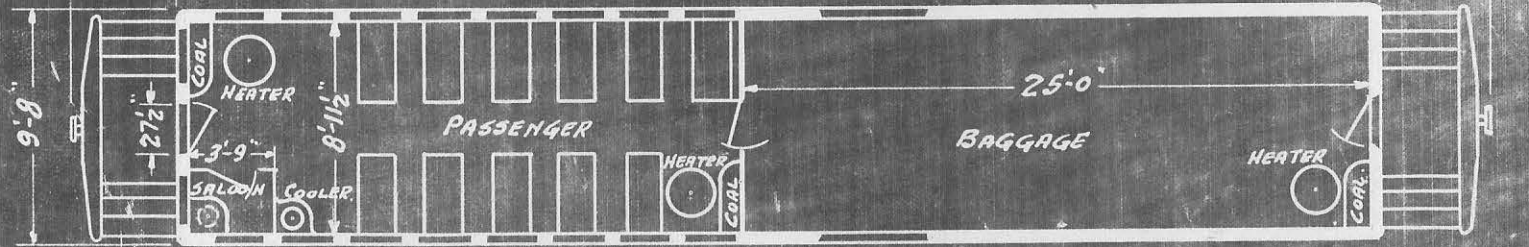
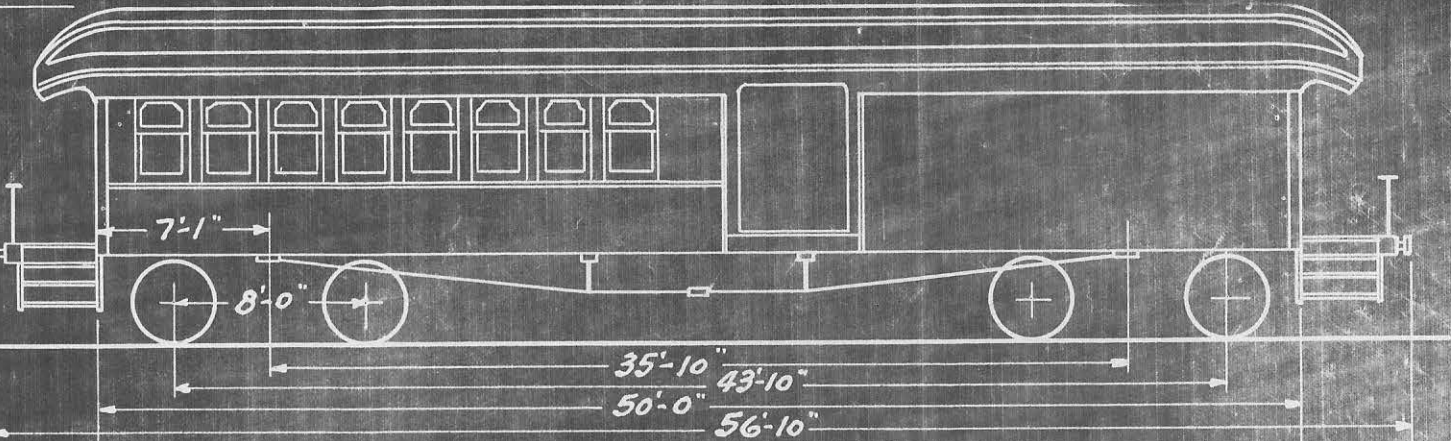
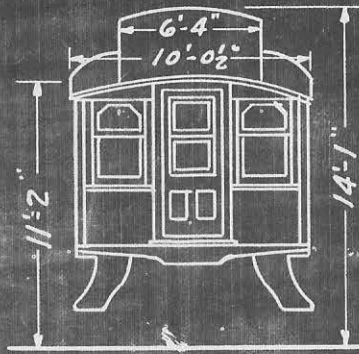

A.F.E. 4821. CAPACITY 20000 LBS.

WEIGHT	65000 LBS.
LENGTH OVER FRAMING	50'-0"
" " BUFFERS	56'-10"
WIDTH " FRAMING	9'-8"
" " CROWN MLDG.	10'-0 1/2"
SEATING CAPACITY	22

TRUCK CENTERS	35'-10"
TOTAL WHEEL BASE	43'-10"
TRUCK " "	8'-0"
WHEELS STEEL DIAM.	36"
KIND OF TRUCK	METAL FACED
JOURNALS SIZE	4 1/2" x 8"

AIR BRAKE	10" x 12" CYL.
AIR SIGNAL	
HEATER	3-N.Y. STOVES. DIRECT STEAM.
HEATER PIPING	2 FT.
WATER SYSTEM	GRAVITY.

FINISH EXTERIOR	GROOVED SHEATHING.
" INTERIOR	OAK & CHERRY
HEAD LINING	GRAINED OAK.
LIGHTING	OIL.
DRAFT GEAR	3-SPRING
COUPLER	LONG SHANK 6 1/2" BUTT.

CA

BUILT BY BARNEY & SMITH, 1879.

PASSENGER & BAGGAGE ~~535, 536~~ 536. ~~534, 535~~

57

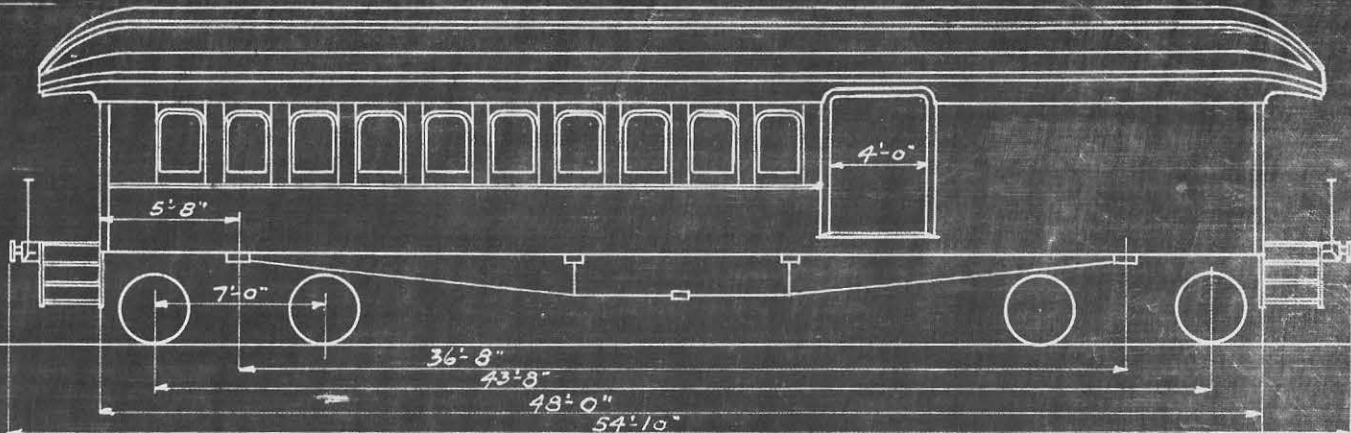
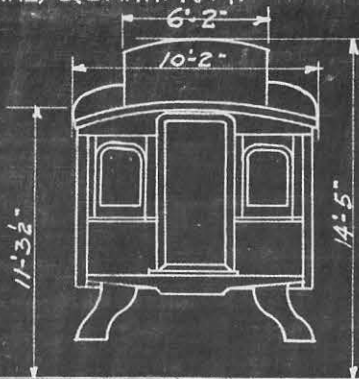

\* 535, 536.

CAR No 507 SCRAPPED A.F.E. 38872.

CAR No 534 SCRAPPED A.F.E. 43683

CAR No 535 SOLD. P.R. ORDER \$-4909.

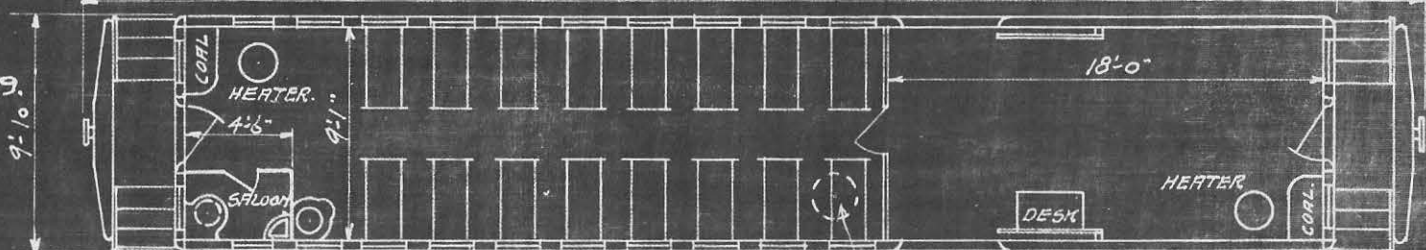

\* THESE CARS HAVE "H" SECTION BODY BOLSTERS & "I" BEAM NEEDLE BEAM. A.F.E. 26925.

WEIGHT LBS. 49000  
 LENGTH OVER FRAMING, 48'-0"  
 LENGTH OVER BUFFERS, 54'-10"  
 WIDTH OVER FRAMING, 9'-10"  
 WIDTH OVER CROWN MLD'G, 10'-2"  
 SEATING CAPACITY, 32

TRANSOM CENTER, 36'-8"  
 TOTAL WHEEL BASE, 43'-8"  
 TRUCK WHEEL BASE, 7'-0"  
 WHEELS STEEL TIRE DIAM., 33"  
 KIND OF TRUCK, WOOD.  
 JOURNALS, 4 1/4" x 8"

AIR BRAKES, 10x12 CYL.  
 AIR SIGNAL,  
 HEATER, 2 (MAKER) SPEAR  
 HEATER PIPING,  
 WATER SYSTEM, GRAVITY.

FINISH, EXTERIOR, GROOVED SHEATH'G.  
 FINISH, INTERIOR, ASH & WALNUT.  
 HEAD LINING, CLOTH.  
 LIGHTING, OIL, 5 LTS.  
 DRAFT GEAR, 3-SPRING  
 COUPLER, LONG SHANK, 6 1/2" BUTT.

CA

11-22-39 5-26-43  
 Rev. 5-1-24. Rev. 12-15-24. Rev. 3-1-26. Rev. 6-1-30. Rev. 12-18-31. REV. 11-10-38.



BUILT BY - PULLMAN CO. 1888.  
 PASSENGER & BAGGAGE.  
 CAR NO 3.  
 N. & S. F.

G.N.RY. No 539

58

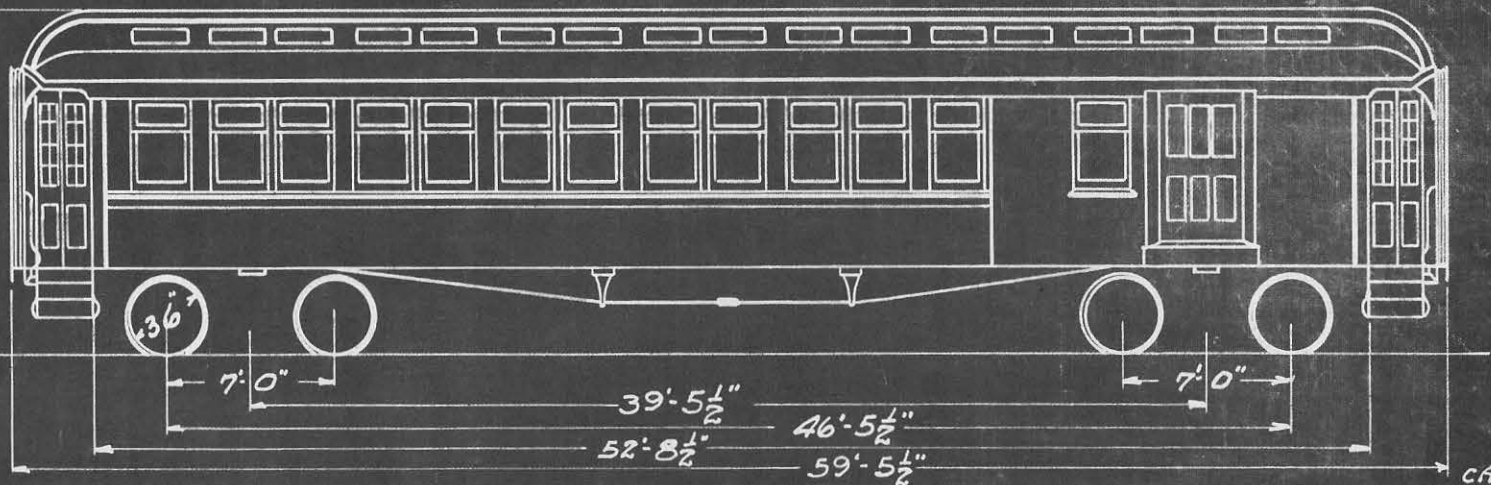
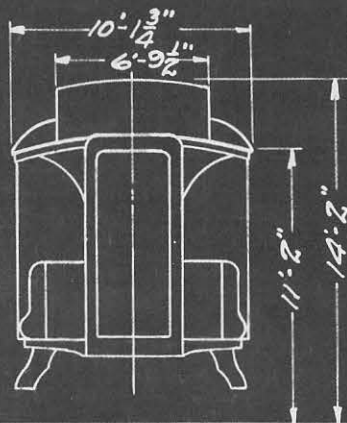
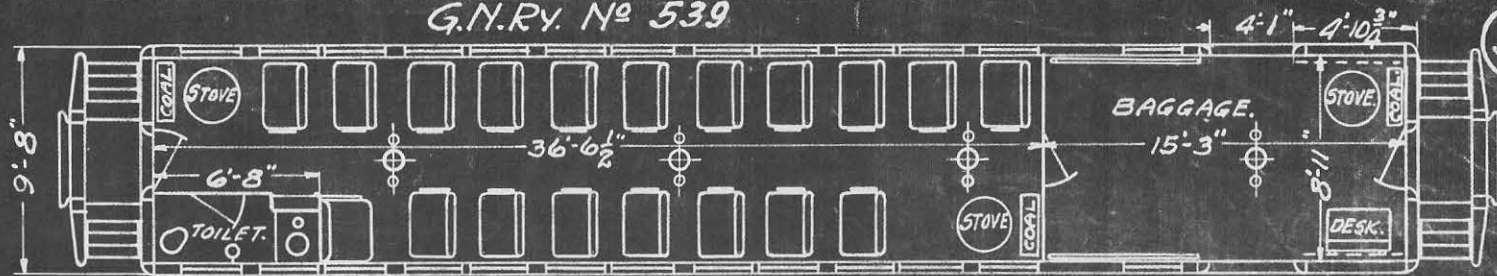

REV. 5-1-24. REV. 3-1-26. REV. 6-1-30. 5-26-43

WEIGHT LBS. 70305.  
 LENGTH OVER FRAME. 52'-8 1/2"  
 " " BUFFERS. 59'-5 1/2"  
 WIDTH OVER FRAME. 9'-8"  
 " " CROWN MOLDG. 10'-1 3/4"  
 SEATING CAPACITY. 38.  
 CAPACITY LBS. 30000.

TRANSOM CENTERS. 39'-5 1/2"  
 TOTAL WHEEL BASE. 46'-5 1/2"  
 TRUCK " " 7'-0"  
 WHEELS - STEEL 36" DIA.  
 KIND OF TRUCK METAL FACED.  
 JOURNALS. COLLARLESS 4 1/2" X 8 1/2"

AIR BRAKE. WESTINGHOUSE 12" X 12".  
 " SIGNAL.  
 HEAT. - STEAM AND N.Y. STOVES.  
 HEATING PIPE. 2" DIA. 146'-0" PASS.  
 " " 1 1/2" DIA. 106'-0" BAGG.  
 VESTIBULE. NARROW, PULL. STD.  
 DRAFT GEAR. MINER.  
 WATER SYSTEM

FINISH, EXTERIOR - GROOVED SHEATHING.  
 " INTERIOR - PASS. MAHOGANY.  
 " BAGG. BEADED LINING.  
 HEADLINING - LIGHT GREEN  
 LIGHTING - OIL.  
 COUPLER LONG SHANK 6 1/2" BUTT.

BUILT BY BARNEY & SMITH 1901  
REBUILT 1928 G.N.R.Y.

PASSENGER & BAGGAGE N° 541.

59

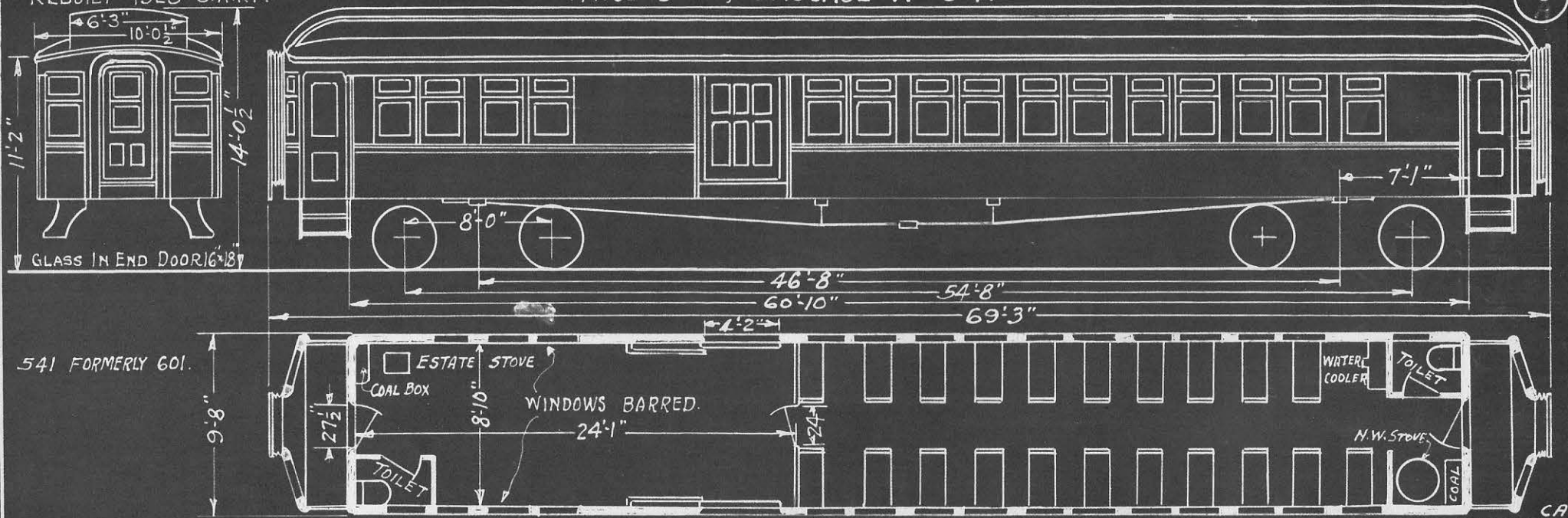

541 FORMERLY 601.

WEIGHT	106100 LBS.
LENGTH OVER FRAMING	60'-10"
" " BUFFERS	69'-3"
WIDTH " FRAMING	9'-8"
" " CROWN MOULDING	10'-0 1/2"
SEATING CAPACITY	42
CAPACITY	20000 LBS

TRUCK CENTERS	46'-8"
TOTAL WHEEL BASE	54'-8"
TRUCK " "	8'-0"
WHEELS-STEEL	36"
KIND OF TRUCK	METAL FACED
JOURNALS	5"x9"

AIR BRAKE CYL	14"x12"
HEATERS	1 N.W. STOVE 1 ESTATE STOVE
WATER SYSTEM	GRAVITY.

FINISH EXTERIOR	GROOVED SHEATHING
" INTERIOR	MAHOGANY
HEAD LINING	CANVAS PAINTED
LIGHTING	OIL & ELECTRIC.
DRAFT GEAR	3 SPRING.
COUPLER	LONG SHANK 6 1/2" BUTT.

5-28-38. 5-26-43

BUILT BY BARNEY & SMITH 1901.  
REBUILT G.N. Ry 1928, 1933

# PASSENGER & BAGGAGE CAR NO 545.

60

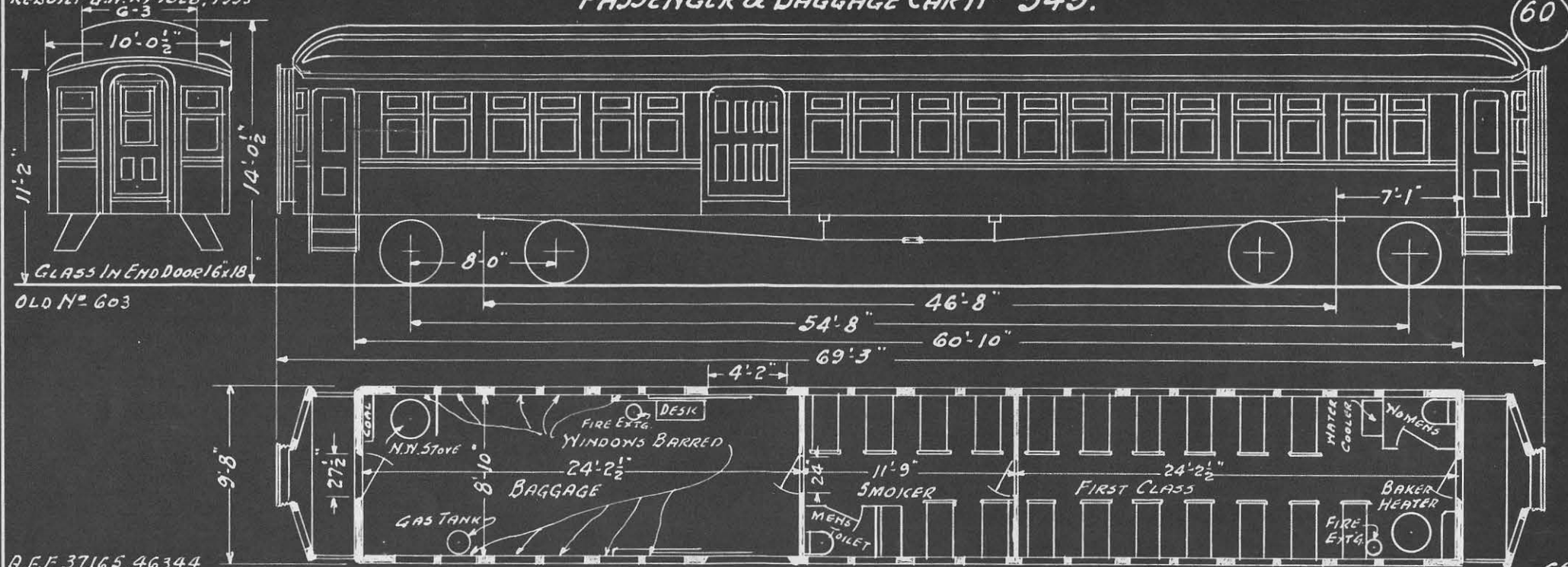

OLD NO 603

A.F.E 37165.46344

WEIGHT	82200 LBS.	TRUCK CENTERS	46'-8"	AIR BRAKE	14" x 12" CYL.	FINISH EXTERIOR	GROOVED SHEATH'G.
LENGTH OVER FRAMING	60'-10"	TOTAL WHEEL BASE	54'-8"	AIR SIGNAL	"	" INTERIOR	MAHOGANY.
" " BUFFERS	69'-3"	TRUCK " "	8'-0"	HEATER - BAKER NO 5 & N.Y. STOVE	"	HEAD LINING	CANVAS PAINTED.
WIDTH " FRAMING	9'-8"	WHEELS - ROLLED STEEL	36" DIA.	HEATER PIPING	1/4" 550 FT.	LIGHTING	GAS & ELECTRIC.
WIDTH " CROWN MLDG.	10'-0 1/2"	KIND OF TRUCK	METAL FACED	WATER SYSTEM	GRAVITY.	DRAFT GEAR	3-SPRING.
CAPACITY	30000 LBS.	JOURNALS SIZE	5" x 9"	SEATING CAPACITY	40.	COUPLER	LONG SHANK 6 1/2" BUTT.

1-25-33. 5-26-43



7-24-28. Rev. 6/30. Rev. 12-18-31. Rev. 11-8-32. Rev. 1-25-33. 12-15-41 5-26-43

BUILT BY BARNEY & SMITH - 1902  
REBUILT BY G. M. 1928

# PASSENGER & BAGGAGE CAR Nos 549, 550

61

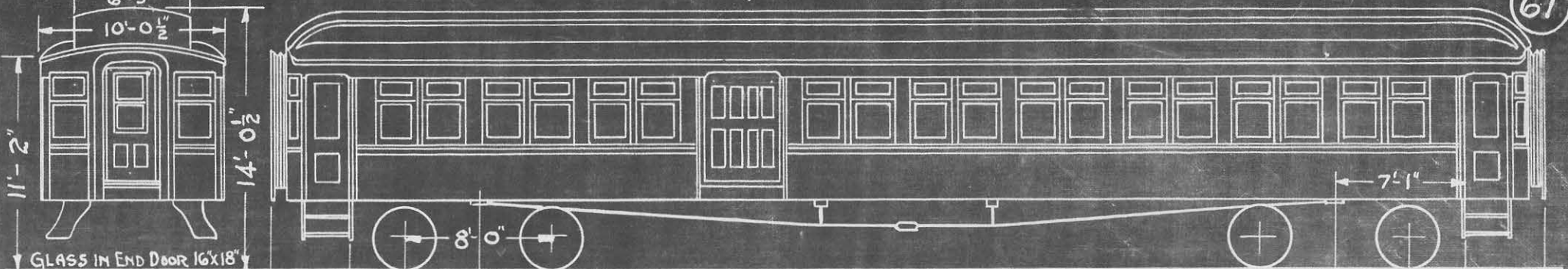

\* CAR No 550 HAS GAS & OIL LIGHTS ONLY, NO ELEC. TRAIN LINE.

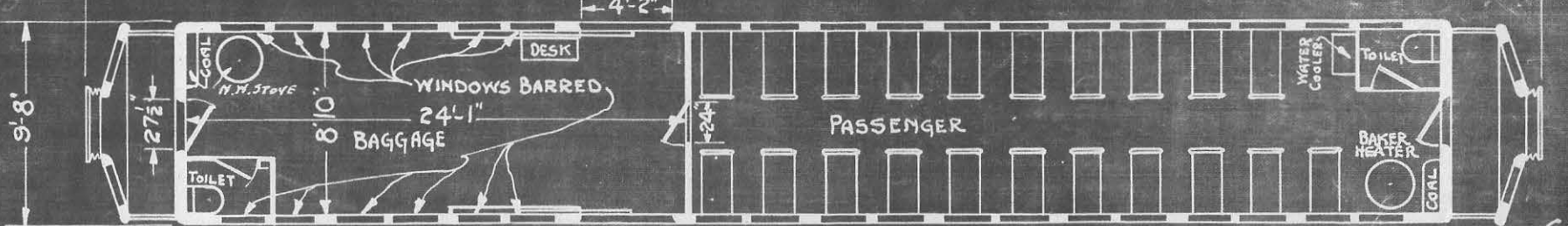

A.F.E. 62474  
A.F.E. 37165

WEIGHT	80000 LBS.
LENGTH OVER FRAMING	60'-10"
LENGTH OVER BUFFERS	69'-3"
WIDTH OVER FRAMING	9'-8"
WIDTH OVER CROWN MOULDING	10'-0 1/2"
CAPACITY	30000 LBS
SEATING CAPACITY	42

TRANSOM CENTERS	46'-8"
TOTAL WHEEL BASE	54'-8"
TRUCK WHEEL BASE	8'-0"
WHEELS, STEEL DIAM.	36"
KIND OF TRUCK	METAL FACED
JOURNALS	5'x9"

AIR BRAKE	CYLINDER	14" x 12"
AIR SIGNAL		N.Y.
HEATER	BAKER No 5 & M.W. STOVE	
	SAFETY STEAM	
HEATER PIPING	1 1/4"	550 FT.
WATER SYSTEM		GRAVITY

FINISH, EXTERIOR	GROOVED SHEATHING
FINISH, INTERIOR	MAHOGANY
HEAD LINING	CANVAS PAINTED
LIGHTING - CARS	550 - GAS & OIL
" "	549 - * OIL, GAS & ELECTRIC
DRAFT GEAR	3-SPRING
COUPLER	LONG SHANK 6 1/2" BUTT.

BUILT BY BARNEY & SMITH 1902

PASSENGER & BAGGAGE CAR NOS. 551, 552.

62

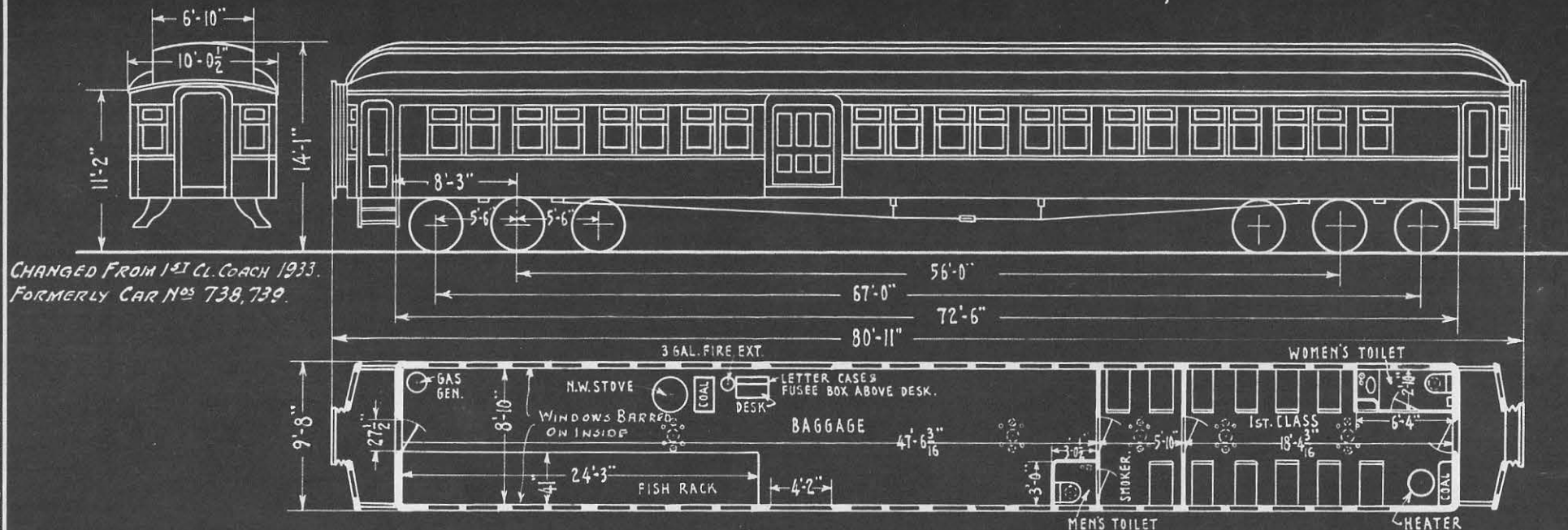

CHANGED FROM 1<sup>ST</sup> CL. COACH 1933.  
FORMERLY CAR NOS 738, 739.

9-21-33. Rev. 12.6.33 5-26-43

A.F.E. 47371.

CA

WEIGHT	111900 LBS.	TRUCK CENTERS	56'-0"	AIR BRAKES	14" x 12" CYL.	FINISH EXTERIOR	GROOVED SHEATHING.
LENGTH OVER FRAMING	72'-6"	TOTAL WHEEL BASE	67'-0"	AIR SIGNAL	"	" INTERIOR	MAHOGANY.
" " BUFFERS	80'-11"	TRUCK " "	11'-0"	HEATER	BAGGAGE ROOM	HEAD LINING	CANVAS PAINTED.
WIDTH " FRAMING	9'-8"	WHEELS ROLLED STEEL	36" DIAM.		PASS. END. BAKER 2 COIL STEEL HEATER.	LIGHTING	GAS & ELECTRIC.
" " CROWN MOLDING	10'-0 1/2"	KIND OF TRUCK	METAL FACED	HEATER PIPING	1/4"	DRAFT GEAR	3 SPRING.
SEATING CAPY. 24 BAG. CAPY.	LBS.	JOURNALS	5x9" HYATT ROLLER BEARING.	WATER SYSTEM	GRAVITY.	COUPLER	LONG SHANK. 6 1/2" BUTT.

BUILT BY B & S. Co 1910.

# PASSENGER & BAGGAGE CAR Nos 553 to 558 EXCEPT 556

63

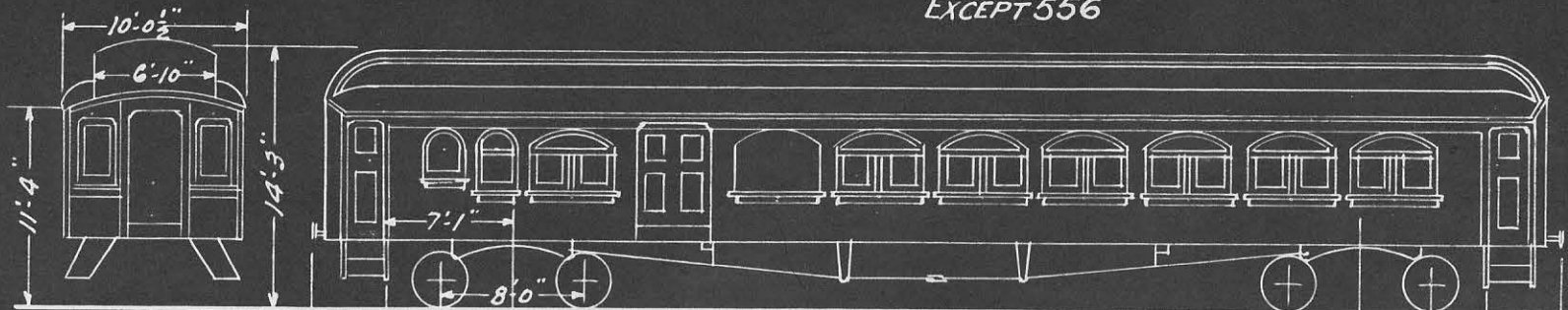

FORMERLY 1<sup>ST</sup> CL. COACH  
Nos 800 to 852.

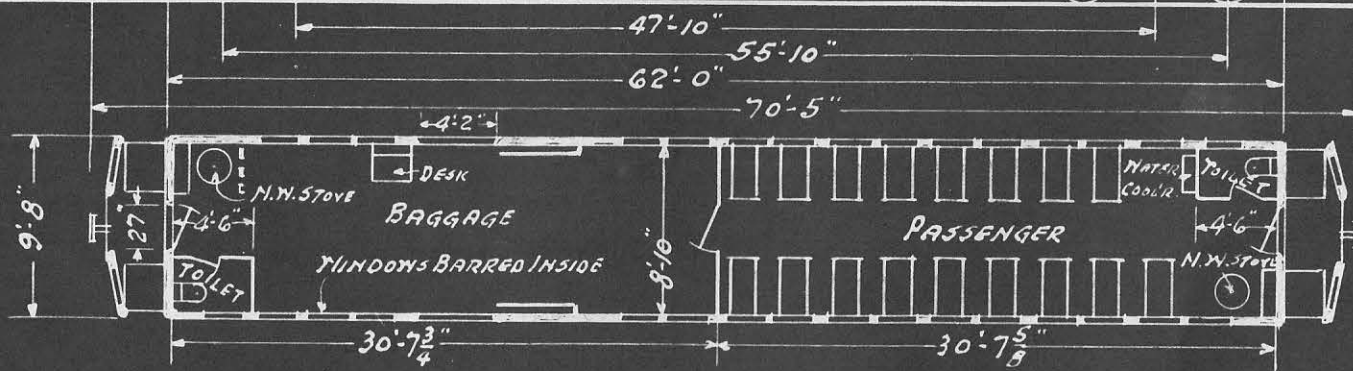

A.F.E 47692.

WEIGHT	91400 LBS.	TRUCK CENTERS	47'-10"	AIR BRAKE	14" x 12" CYL.	FINISH-EXTERIOR	GROOVED SHEATHING.
LENGTH OVER FRAMING	62'-0"	WHEEL BASE-TRUCK	8'-0"	STOVES	TSYO. N.Y.	FINISH-INTERIOR	CUBAN MAHOGANY.
" " BUFFERS	70'-5"	" " -TOTAL	55'-10"	HOPPER-DRY	No 2 EARTHEN HOPPER.	HEAD LINING	3 PLY YENEER-PAINTED.
WIDTH " FRAMING	9'-8"	WHEELS-ROLLED STEEL	36 1/2" DIA.			LIGHTING	OIL & ELECTRIC.
" " CROWN MLOG.	10'-0 1/2"	KIND OF TRUCK	METAL FACED.			DRAFT GEAR	3-SPRING.
SEATING CAPACITY	34.	JOURNALS-SIZE	5" x 9"			COUPLER	LONG SHANK. 6 1/2 BUTT.

1.19.34. 5-26-43

CA



BUILT BY B. & S. C. CO 1910.  
638 TO 559-1935.

62 FT. PASSENGER & BAGGAGE CAR NO 559.

64

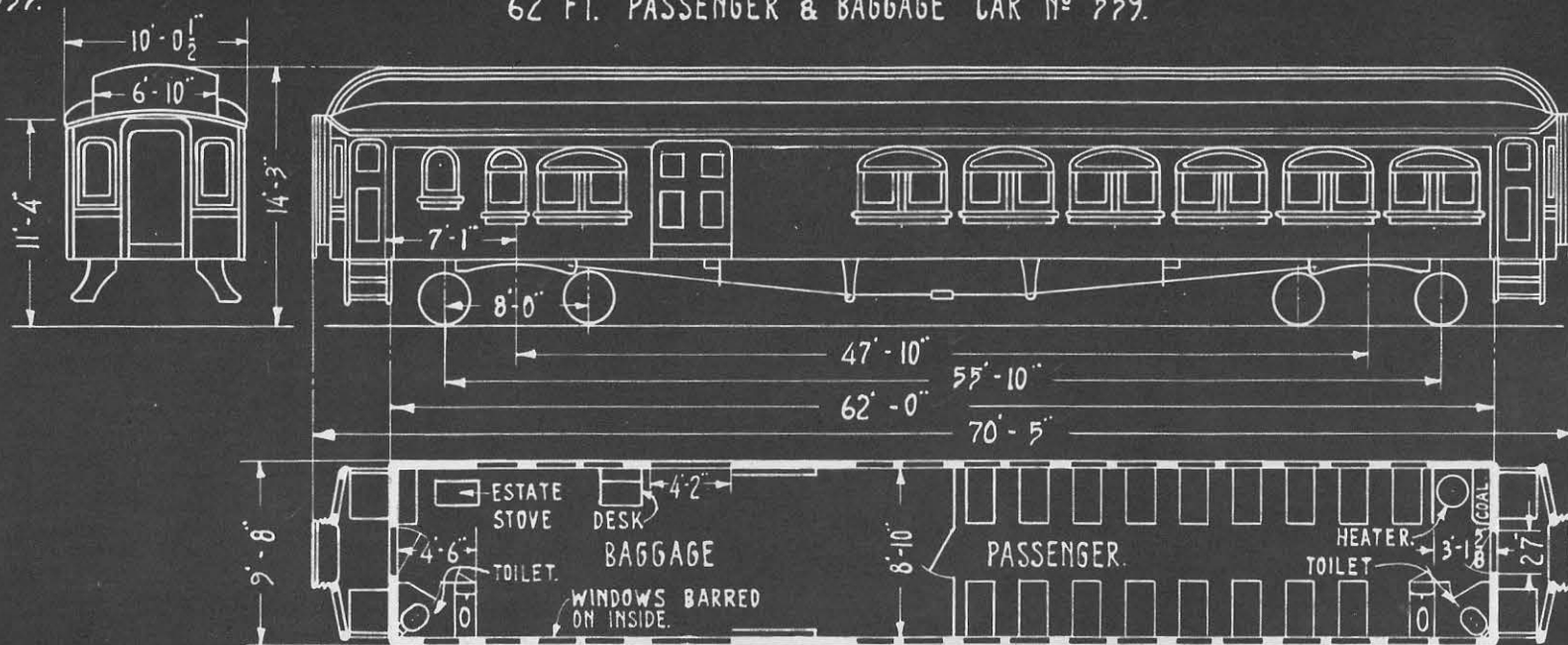

A. F. E. 50270.

CA

WEIGHT	96500 LB.	TRANSOM CENTERS	47'-10"	AIR BRAKE	14" x 12" CYL.	FINISH- EXTERIOR GROOVED SHEATHING.
LENGTH OVER FRAMING	62'-0"	TOTAL WHEEL BASE	55'-10"	STOVE	ESTATE.	" INTERIOR BIRCH.
LENGTH OVER BUFFERS	70'-5"	TRUCK	8'-0"	HEATER	GOLD SYSTEM.	HEADLINING 3 PLY VENEER PAINTED
WIDTH OVER FRAMING	9'-8"	WHEELS, STEEL, DIA.	36 1/2"	HOT WATER & STEAM COMBINED.		LIGHTING ELEC. & OIL.
WIDTH OVER CROWN MLDG.	10'-1 1/2"	KIND OF TRUCK	METAL FACED	HEATER PIPING 1 1/4"	400 FT.	DRAFT GEAR 3 SPRING.
SEATING CAPACITY	34	JOURNALS	5" x 9"	WATER SYSTEM	GRAVITY.	COUPLER LONG SHANK 6 1/2" BUTT.

5-26-43

BUILT BY BARNEY & SMITH 1907  
REBUILT TO COMB. BAG. & PASS. CAR.

# COMB. PASS. & BAG. CARS 560 & 561

65

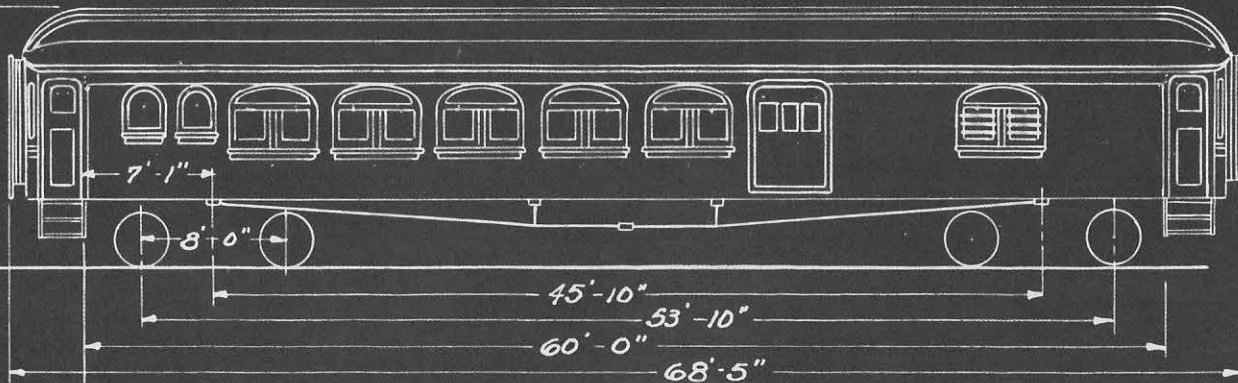
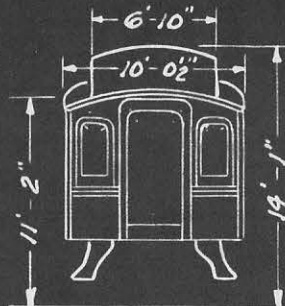

OLD No.	NEW No.	Yr.
637	560	1936
636	561	1937

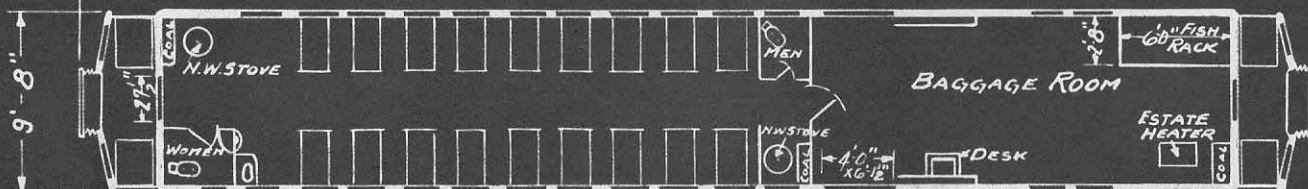

A.F.E. 53292, 50868

C.A.

WEIGHT	
LENGTH OVER FRAMING	60'-0"
" " BUFFERS	68'-5"
WIDTH " FRAMING	9'-8"
" " CROWN MLDG.	10'-0 1/2"
SEATING CAPACITY	36

TRANSOM CENTERS	45'-10"
TOTAL WHEEL BASE	53'-10"
TRUCK WHEEL BASE	8'-0"
WHEELS STEEL	DIAM 36"
KIND OF TRUCK	METAL FACED
JOURNAL SIZE	5x9"

AIR BRAKE	14x12" CYL.
AIR SIGNAL	
STOVES	N.W. & ESTATE
WATER SYSTEM	GRAVITY

FINISH EXTERIOR	GROOVED SHEATHING
" INTERIOR	SELECTED OAK
HEAD LINING	3 PLY VENEER, PAINTED
LIGHTING	OIL & ELECTRIC
DRAFT GEAR	3' SPRING
COUPLER	LONG SHANK 6 1/2" BUTT.

E-16-40 5-26-43

BUILT BY BARNEY & SMITH 1907  
FORMERLY SMOKER CAR N<sup>o</sup> 633 - REBUILT G.N.RY. 1939.

PASSENGER & BAGGAGE CAR N<sup>o</sup> 562

66

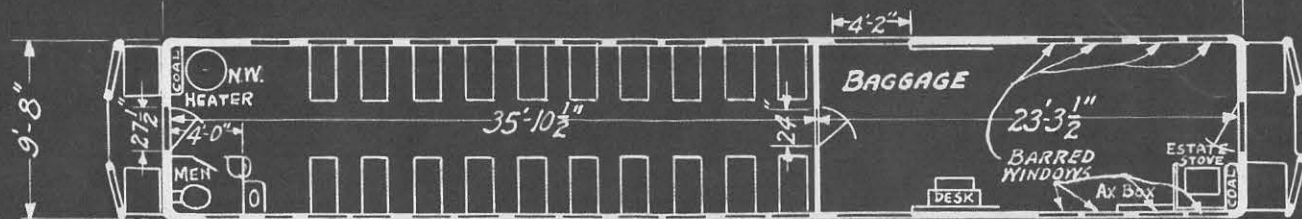
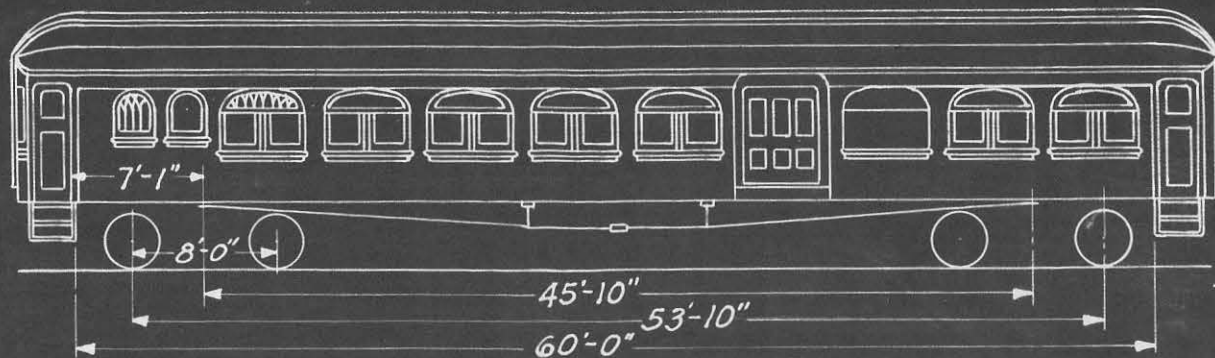
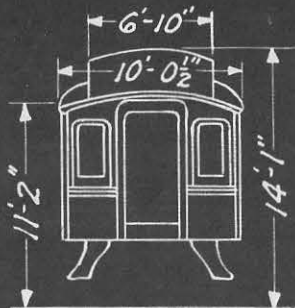

2-15-39. 5-26-43

WEIGHT 87,900  
LENGTH OVER FRAMING 60'-0"  
LENGTH OVER BUFFERS 68'-5"  
WIDTH OVER FRAMING 9'-8"  
WIDTH OVER CROWN MLDG. 10'-0 1/2"  
CAPACITY 25,000 LBS.  
SEATING CAPACITY 40

TRANSOM CENTERS 45'-10"  
TOTAL WHEEL BASE 53'-10"  
TRUCK WHEEL BASE 8'-0"  
WHEELS - STEEL - DIAM. 36"  
KIND OF TRUCK METAL FACED  
JOURNALS, SIZE - 5"x9"

AIR BRAKE 14"x12" CYL.  
AIR SIGNAL, " "  
HEATER (MAKER) N.Y. STOVE-PASS. " " ESTATE STOVE-BAGG.  
DESK  
AX. BOX  
ESTATE STOVE  
COAL

FINISH, EXTERIOR - GROOVED SHEATHING  
FINISH, INTERIOR - SELECTED OAK  
HEAD LINING - 3PLY, VENEER, PAINTED  
LIGHTING - OIL & ELECTRIC  
DRAFT GEAR 3'-5" SPRING  
COUPLER LONG SHANK 6 1/2" BUTT.

CA



BUILT BY B. & S. 1910.  
 CONV. TO P. & B. 1941.

# PASSENGER AND BAGGAGE N° 563, 564

67

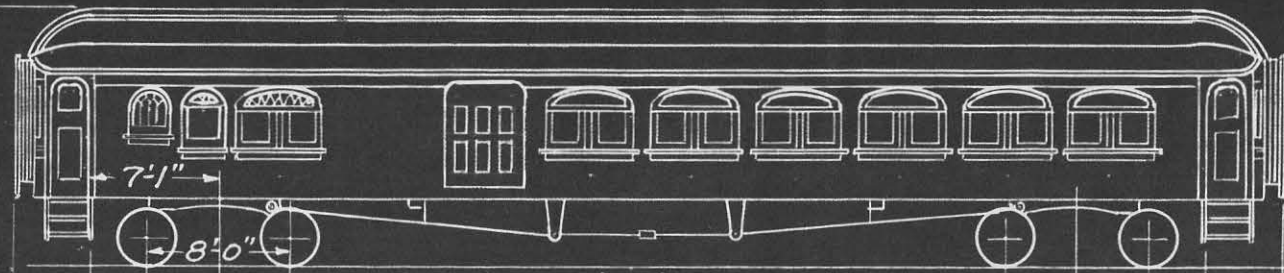
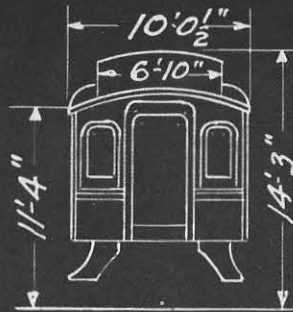

563 FORMERLY COACH 842  
 564 " " 849.

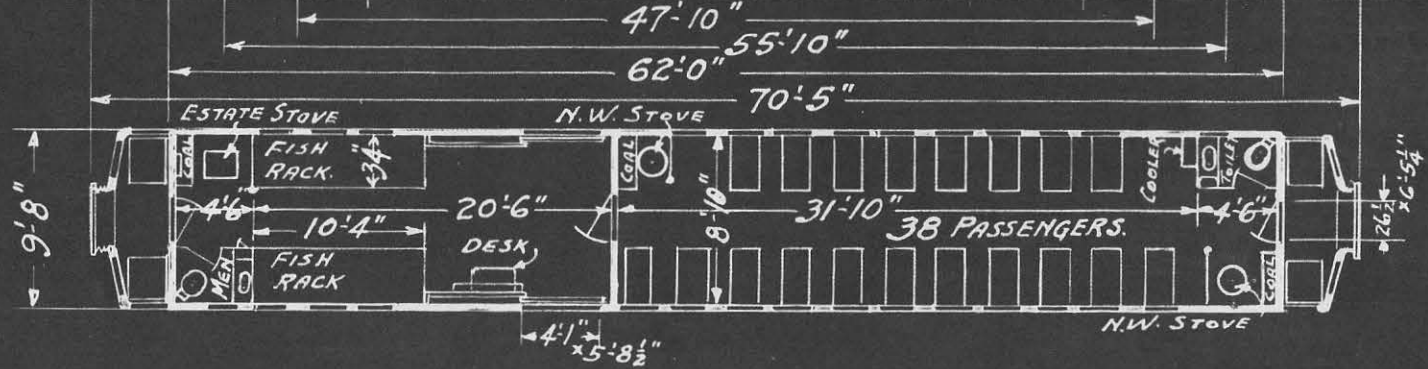

T-16-41 5-26-43

WEIGHT	93060 LBS
LENGTH OVER FRAMING	62'-0"
" " BUFFERS	70'-5"
WIDTH OVER FRAMING	9'-8"
" " CROWN MLDG.	10'-0 1/2"
SEATING CAPACITY	38

TRUCK CENTERS	47'-10"
TOTAL WHEEL BASE	55'-10"
TRUCK WHEEL BASE	8'-0"
WHEELS	STEEL 36"
KIND OF TRUCK	METAL FACED
JOURNAL SIZE	5"x9"

AIR BRAKE	14" x 12"
HEATER	2 N.W. & 1 ESTATE STOVES
SEATS	B. & S.

FINISH EXTERIOR	GROOVED SHEATHING
" INTERIOR	CUBAN MAHOGANY.
HEAD LINING	3 PLY VENEER PAINTED
LIGHTING	OIL & ELECTRIC
DRAFT GEAR	3 SPRING
COUPLER	LONG SHANK 6 1/2" BUTT.

CA

BUILT BY A.C.&F.Co. 1913.  
 STEEL SHEATH APPLIED 1924.  
 CHGD. TO P.&B. 1934.

PASSENGER & BAGGAGE Nos 565, 566, 567.

68

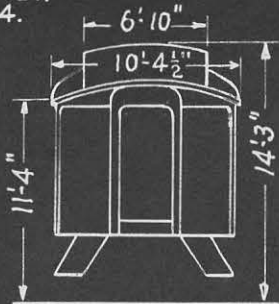

643 CHGD TO 565.  
 644 " " 566.  
 649 " " 567.

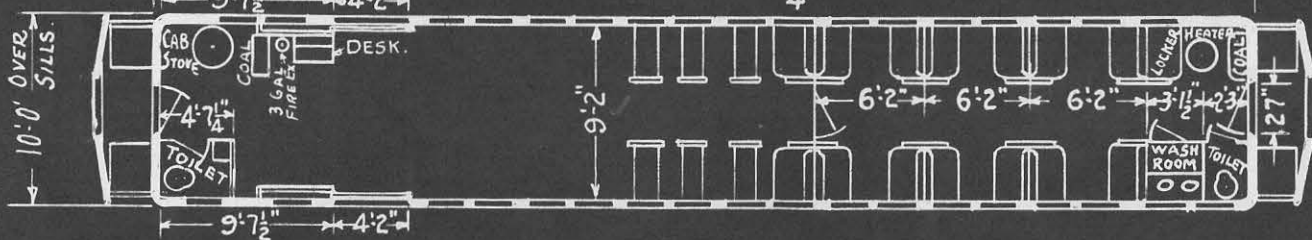
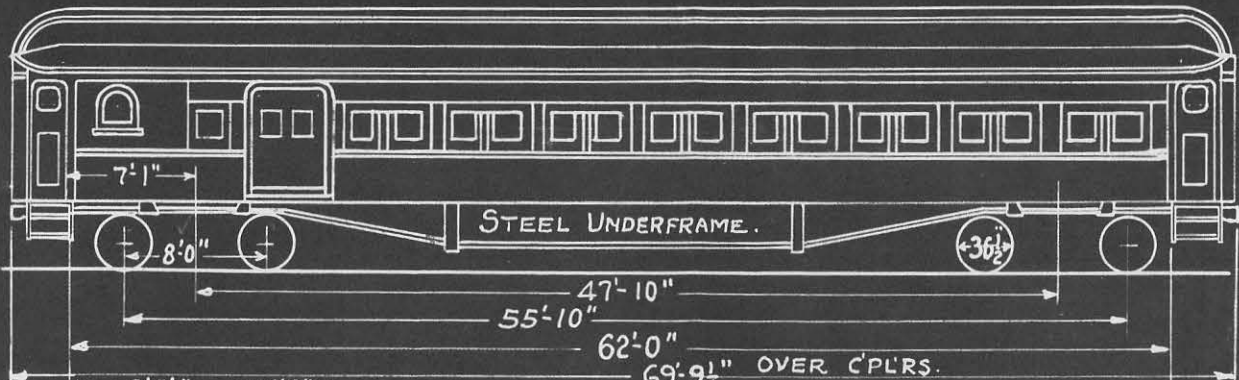

A.F.E. 25588, 25986, 49046.

CA

4-9-35 5-26-43

WEIGHT	119,700 LBS.	TRUCK CENTERS	47'-10"	AIR BRAKE - 18" CYL.	NEW YORK	FINISH - EXTERIOR	STEEL SHEATH.
LENGTH OVER FRAMING.	62'-0"	WHEEL BASE - TRUCKS	8'-0"	" SIGNAL	" "	" - INTERIOR	PAINTED.
" " COUPLERS	69'-9 1/4"	" " - TOTAL	55'-10"	HEATER - GOLD DUPLEX - A.C.&F.CO.	A.C.&F.CO.	HEAD LINING	3 PLY POPLAR VENEER
WIDTH " FRAMING.	10'-0"	WHEELS - STEEL TIRES	36 1/2" DIA.	WATER - PRESSURE SYSTEM.	SIMPLEX.	LIGHTING	OIL - ELECTRIC *
" " CROWN MLDG.	10'-4 1/2"	JOURNALS - SIZE	5" x 9"	CLASP BRAKE		LAMPS	" - BERRYLITE.
SEATING CAPACITY	40.	KIND OF TRUCK	METAL FACED.	DRAFT GEAR	MINER FRICTION A-5-X	COUPLER	SHORT SHANK 9 1/8" BUTT.
				STOVE (BAG. END)	CABOOSE	* OIL LAMPS USED - ELEC. DISCONNECTED	

BUILT BY ELECTRO MOTIVE Co 1925  
CH4D To P.+B. 1941.

# PASSENGER AND BAGGAGE No 568.

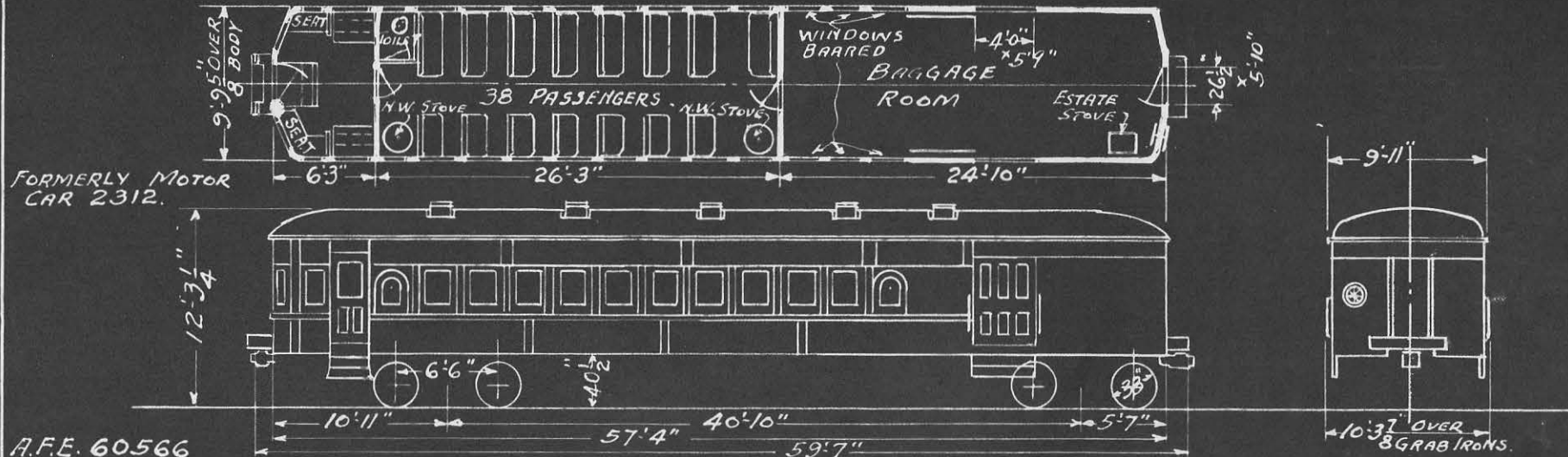

FORMERLY MOTOR CAR 2312.

A.F.E. 60566

CA

WEIGHT - LIGHT	61200 LBS.	TRUCK CENTERS	40'-10"	BOLSTER	BUILT UP	FINISH - EXTERIOR	STEEL
CAPACITY	28000 "	WHEEL BASE - TRUCK	6'-6"	UNDERFRAME	STEEL	" INTERIOR	
LENTH OVER COUPLER FACES	59'-7"	" " - TOTAL	47'-4"	DRAFT GEAR	6 1/2" x 8" SPRING		
" " FRAMING	57'-4"	WHEELS - ROLLED STEEL	33" DIA	HEATING	2 N.W. & 1 ESTATE STOVES		
WIDTH " "	9'-9 5/8"	JOURNALS - SIZE	4 1/2" x 8"	BRAKE	WEST. 12" x 12"		
INSIDE WIDTH	9'-2"	KIND OF TRUCK	STEEL	TRIPLE VALVE	L-2		
" HEIGHT - BAG.	8'-11 1/2"			LIGHTING	ELECTRIC		
" " - GOACH	9'-0 1/2"			COUPLER	BAG. END - S.S. 5' x 5"		
SEATING CAPACITY	38 PASSENGERS			"	PASS. " - S.S. 5' x 7"		

7-11-41  
5-26-43



BUILT BY B & S Co 1910.

STEEL UNDERFRAME AND SHEATHING APPLIED 1925-569, 570.

" " " " " 1924-571.

569 FORMERLY 641  
570 " 642.  
571 " 645

X 10'-4 1/2" ON 571.

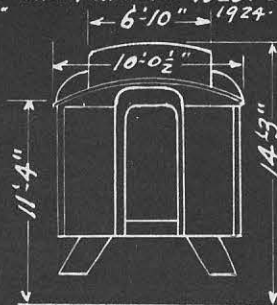

# PASSENGER & BAGGAGE Nos 569, 570, 571,

70

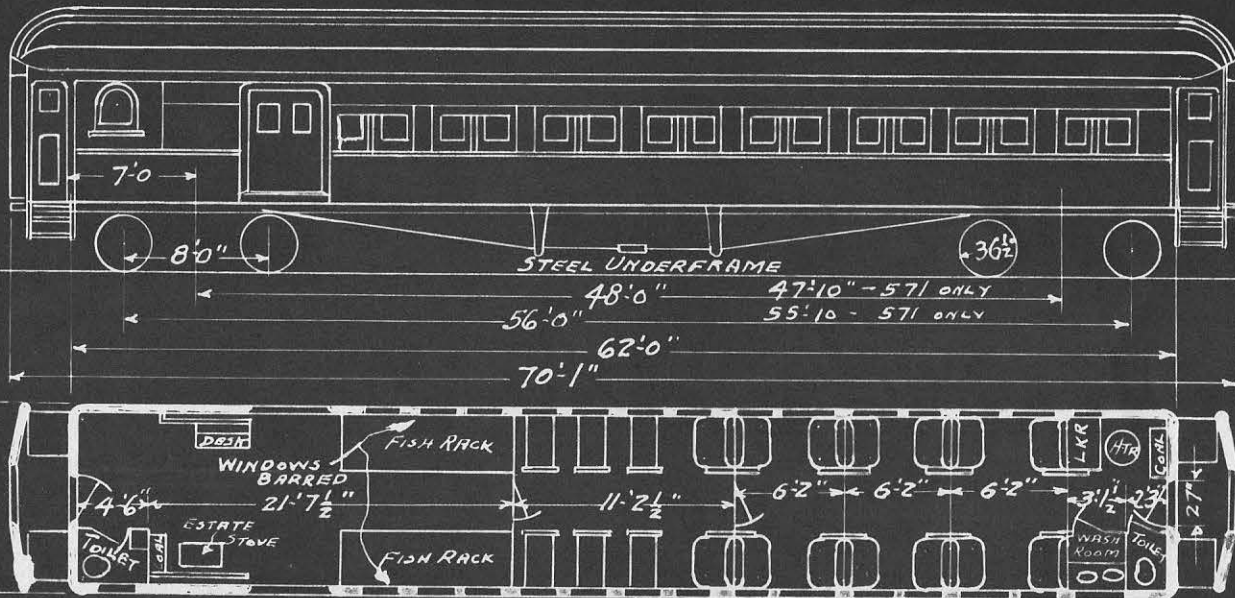

NOTE:-

CAR No 569 BIRCH FINISH AND MAHOGANY STAIN. CAR No 570 BIRCH FINISH, PAINTED ORIENTAL LIMITED COLOR IN PASSENGER END. SLEEPER END MAHOGANY STAIN.

A FE 30284, 42120.

C.A.

WEIGHT	124800 LBS.	TRUCK CENTERS	48'-0"	AIR BRAKE	NY 18" x 12"	FINISH-EXT.	SWEET STEEL
LENGTH OVER FRAMING	62'-0"	WHEEL BASE- TRUCKS	8'-0"	" SIGNAL	NY	" INT.	SEE NOTE.
" " BUFFERS	70'-1"	" " TOTAL	56'-0"	HEATING	1 BAKER HTR & 1 ESTATE ST.	HEAD LINING	3 PLY VENEER PAINTED
WIDTH " FRAMING	9'-8"	WHEELS	STEEL 36 1/2" DIA.	WATER	PRESSURE SYSTEM	LIGHTING	OIL & ELECTRIC
" " CROWN MLDG	x 10'-0 1/2"	JOURNALS	5" x 9"	CLASP BRAKE	571.	LAMPS	4 OIL & 5 BERYLITE.
SEATING CAPACITY	40	KIND OF TRUCK	METAL FACED.			DRAFT GEAR	A-5-P MINER.
BAGGAGE "	30000 LBS.					COUPLER	5x7 "E" SWIV. BUTT.

5-26-43

BUILT BY BARNEY & SMITH CO. 1906

COMBINATION COACH NOS. 582 TO 584

71

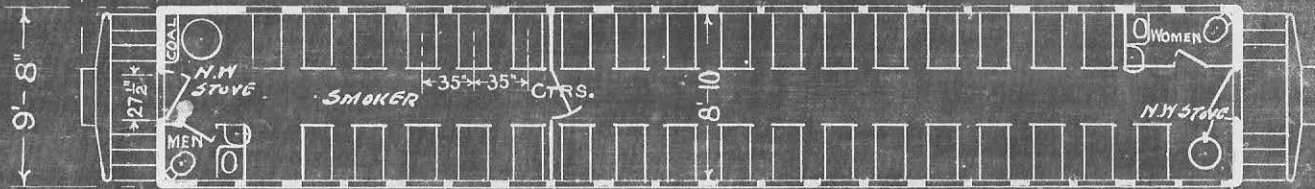
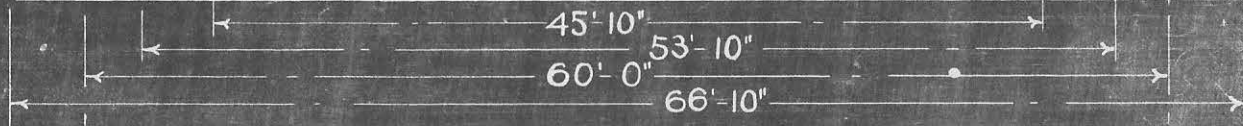
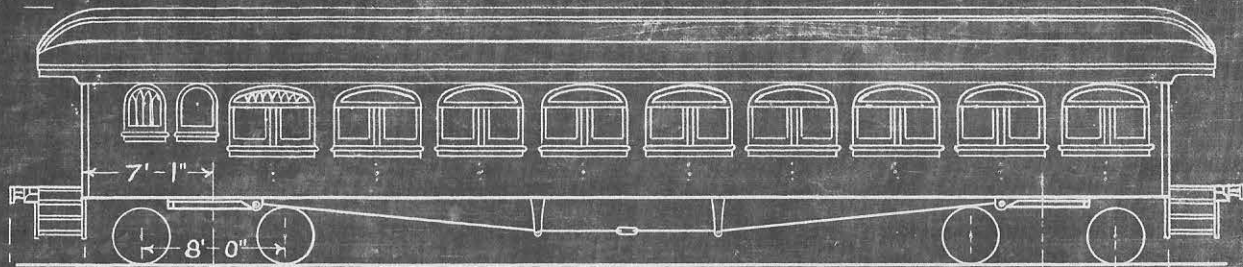
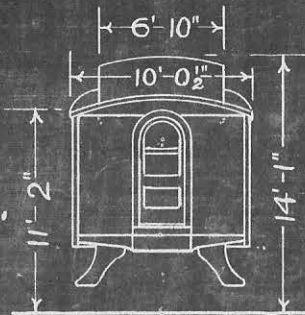

OLD Nos. 260 TO 274.  
 Rev. 6-1-30. Rev. 8-12-35. 5-26-43  
 Rev. 5-1-24. Rev. 3-1-26. Rev. 7-6-26. Rev. 2-10-27. Rev. 11-1-27. Rev. 3-1-28. Rev. 6-11-28. Rev. 6-2-29.

WEIGHT	92000 LBS.	TRANSOM CENTERS	45'-10"	AIRBRAKE	14 x 12" Cyl.	FINISH-EXTERIOR-GROOVED SHEATHING
LENGTH OVER FRAMING	60'-0"	TOTAL WHEEL BASE	53'-10"	AIR SIGNAL		FINISH-INTERIOR-MAHOGANY
LENGTH OVER BUFFERS	66'-10"	TRUCK WHEEL BASE	8'-0"	HEATER	2-N.Y. STOVES	HEADLINING-3PLY VENEER, PAINTED
WIDTH OVER FRAMING	9'-8"	WHEELS- STEEL -				LIGHTING
WIDTH OVER CROWN MLDG.	10'-0 1/2"	KIND OF TRUCK	DIAM. 36"			OIL
SEATING CAPACITY	68.	JOURNALS - SIZE	METAL FACED.	EMPIRE DECK		DRAFT GEAR
			5" x 9"	WATER SYSTEM	GRAVITY.	COUPLER
						LONG SHANK
						6 1/2" BUTT.

REV. 3-1-26, REV. 6-1-30, REV. 11-7-30, REV. 6-21-37, 7-23-41, 12-15-41, 5-26-43,  
 OLD Nos. 226 TO 247, REV. 7-1-23, REV. 5-1-24, REV. 12-15-24, REV. 6-1-25.

BUILT BY B.&S. 1905 617 TO 624.  
 " " " 1906 625 TO 632.

STEEL UNDERFRAME, SHEATHING & VESTIBULE APPLIED 1923, 24, 25.

# SMOKERS CAR NOS. 617 TO 632. EXCEPT 620, 621, 625, 627, 632.

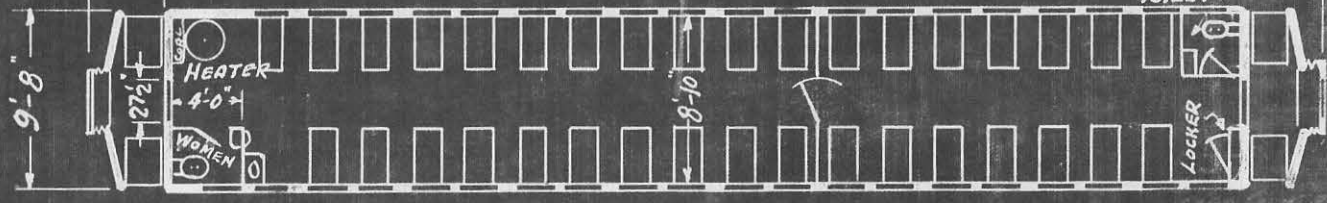
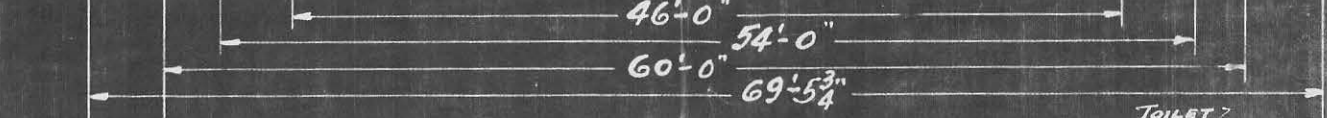
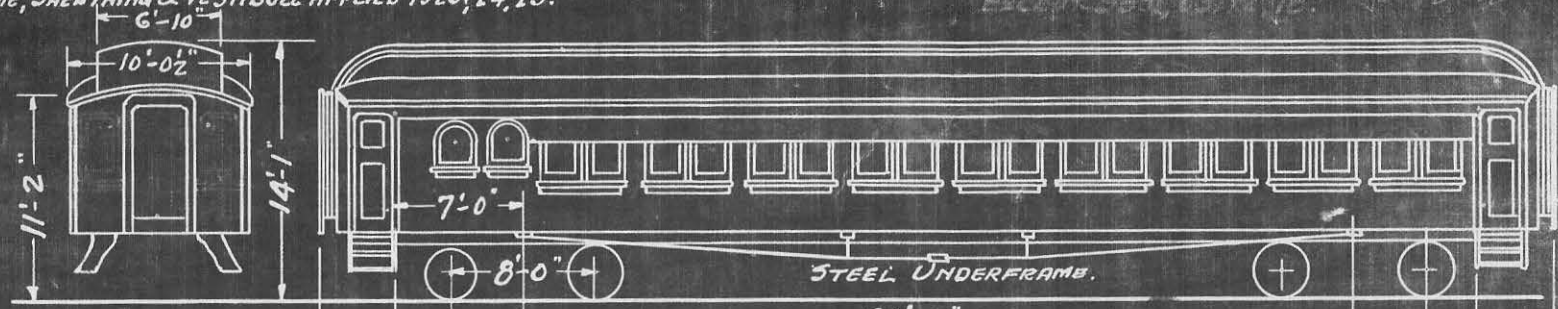

- 617 } WT. = 126500 #
- 618 } EQUIPPED WITH
- 619 } \* PARTITION
- 622 } A AXLE LIGHT GEN.
- 623 } BATTERY.
- 624 }
- 626 } WT. = 122700 #
- 628 }
- 629 }
- 630 }
- 631 }

A.F.E. 19749, A.F.E. 52460, 56658

WEIGHT	SEE ABOVE	TRUCK CENTER	46'-0"	AIR BRAKE	18"x12" CYL - NEW YORK CO.	FINISH EXTERIOR	STEEL SHEATH
LENGTH OVER FRAMING	60'-0"	TOTAL WHEEL BASE	54'-0"	AIR SIGNAL	" " "	" INTERIOR	STEEL
" " BUFFERS	69'-0 1/4"	TRUCK " "	8'-0"	HEATER	GOLDS SYSTEM.	HEAD LINING	3 PLY VENEER PAINTED.
WIDTH " FRAMING	9'-8"	WHEELS - STEEL	DIAM. 36"	HEATER PIPING	DOUBLE COIL STEAM HEAT.	LIGHTING	ELECTRIC.
" " CROWN MLOG.	10'-0 1/2"	KIND OF TRUCK	METAL FACED.	WATER SYSTEM	PRESSURE	DRAFT GEAR	(FRISTON) MINER
SEATING CAPACITY	70	JOURNALS SIZE	5 x 9"	AXLE LIGHT GEN.	A	COUPLER	SWIVEL BUTT.
		PARTITION	*				

CARS 617 TO 631 HAVE FLUSH HOPPERS AND PRESSURE WATER TANK.



BUILT BY R.C. & F. Co. 1913  
 STEEL SHEATH. APPLIED 1924-646 to 659

SECOND CLASS COACH & SLEEPER Nos 646, 647, 648, 650, 651, 652, 654 to 659, 666, 667,

73

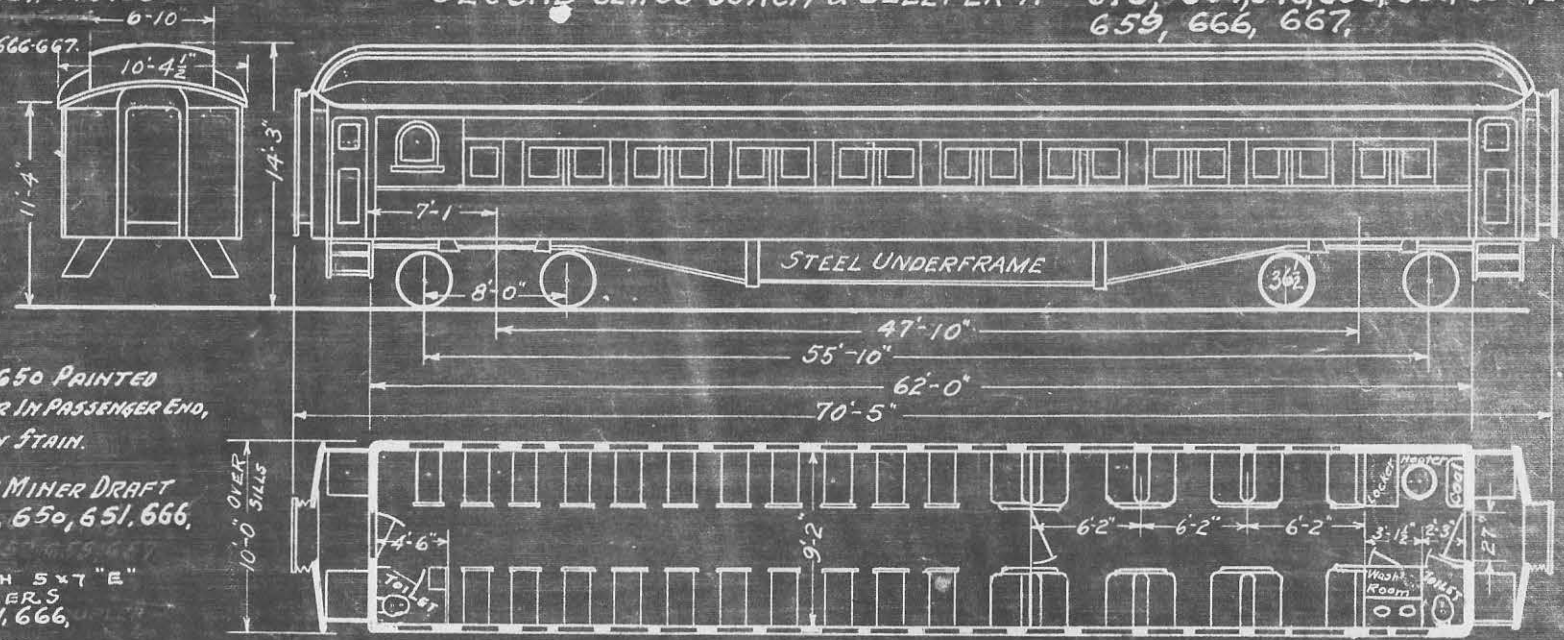

573 Bsq  
 L 23' 6 3/4"  
 W 9'  
 H 10' 4 1/2"  
 CUB 30000

NOTE: - \*  
 CAR Nos 646 to 650 PAINTED  
 ORIENTAL LIMITED COLOR IN PASSENGER END,  
 SLEEPER END MAHOGANY STAIN.

♦ CARS EQUIPPED WITH MINER DRAFT  
 GEAR 646, 647, 648, 650, 651, 666,  
 655, 657, 659.

+ CARS EQUIPPED WITH SXT "E"  
 SWIVEL BUTT COUPLERS  
 646, 647, 648, 650, 651, 666,

A.F.E. 25986, A.F.E. 32959, 25588, 42120

WEIGHT	123000 LBS.	TRUCK CENTERS	47'-10"	AIR BRAKE	18" CYL. New York.	FINISH, EXTERIOR	STEEL SHEATH.
LENGTH OVER FRAMING	62'-0"	WHEEL BASE-TRUCKS	8'-0"	" SIGNAL	" "	" INTERIOR	BIRCH, MAH. ST. *
" " BUFFERS	7'-5"	" " TOTAL	55'-10"	HEATER	GOLD DUPLEX A.C. & F. Co.	HEAD LINING	3 PLY POPLAR VENEER.
WIDTH " FRAMING	10'-0"	WHEELS STEEL TIRES	36" DIA.	WATER -PRESSURE SYSTEM		LIGHTING	ELECTRIC
" " CROWN MLDG.	10' 4 1/2"	JOURNALS - SIZE	5" X 9"	CLASP BRAKE	CAR Nos 643 to 660 666, 667	LAMPS	BERRYLITE
SEATING CAPACITY	70.	KIND OF TRUCK	METAL FACED	DRAFT GEAR	♦ MINER FRICTION A-5 X.	DRAFT GEAR	♦ FARLOW 6" X 8" SPRING.
				BUFFER	MINER FRICTION B-10 X.	COUPLER*	LONG SHANK 6 1/2" BUTT.

REV 5-2-41 12-15-44 5-26-43  
 REV 6-1-30 Rev. 11-7-30. Rev. 12-19-31. Rev. 9-20-33. Rev. 10-15-34. Rev. 4-9-35 11-22-39  
 12-15-24 Rev. 5-15-25. Rev. 6-1-25. Rev. 3-1-26. Rev. 3-1-28. Rev. 11-20-28. Rev. 3-11-29.

PB

BUILT BY B. & S. C. Co. 1910  
 STEEL UNDERFRAME & SHEATHING APPLIED 1925

# 62 FT. SECOND CLASS COACH 668, 669.

74.

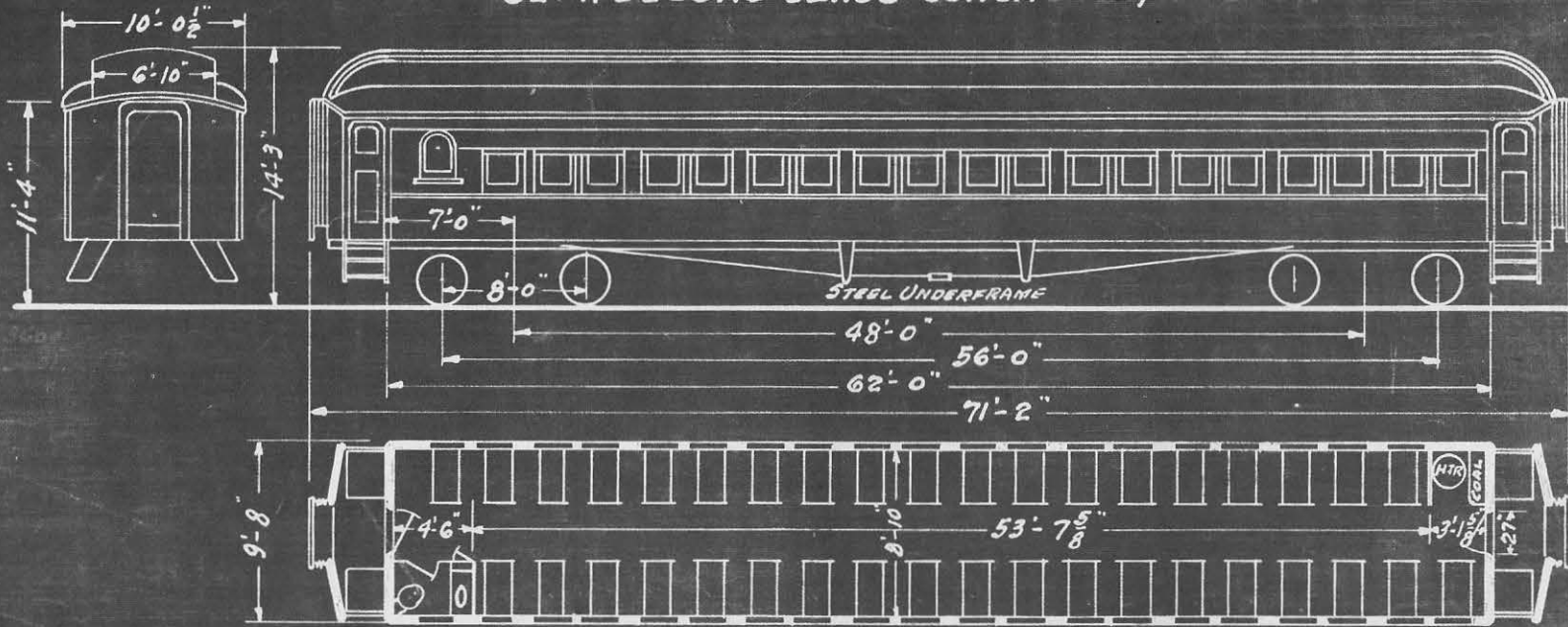

A.F.E 19749, 56658

PB

WEIGHT	126600 LBS.	TRUCK CENTERS	48'-0"	AIR BRAKE	18" x 12" CYL. NEW YORK	FINISH EXTERIOR	SHEET STEEL
LENGTH OVER FRAMING	62'-0"	WHEEL BASE - TRUCK	8'-0"	AIR SIGNAL	" "	" INTERIOR	PLASTIC
" " BUFFERS	71'-2"	" " - TOTAL	56'-0"	HEATER	GOLD SYSTEM	HEAD LINING	3 PLY VENEER PAINTED
WIDTH OVER FRAMING	9'-8"	WHEELS	STEEL 36" DIA.	HEATER PIPING	1 1/4" 400 FT.	LIGHTING	ELECTRIC
" " CROWN MLDG.	10'-1 1/2"	KIND OF TRUCK	METAL FACED	WATER SYSTEM	GRAVITY	DRAFT GEAR	MINER
SEATING CAPACITY	76	JOURNALS	SIZE 5" x 9"	FLUSH HOPPERS.		COUPLER	5 x 7" "E" SWIV. BUTT.

6-1-25. REV. 3-1-26. REV. 6-1-30. / 2-15-41 5-26-43

5-26-43  
 Rev. 5-1-24 Car Nos. 4011 & 4012 Added. A.F.E. 24583. REV. 4-20-37. 11-22-39  
 Rev. 7-1-23. 1ST CL. COACH CHANGED PER A.F.E. 22123. REV. 6-1-30. REV. 5-28-38.  
 FORMERLY FIRST CLASS COACH CHANGED PER A.F.E. 20533 & 20766. REV. 3-1-26.

BUILT BY AM. C. & F. Co 1900 712.

COMBINATION COACH CAR NOS. [REDACTED] 712- [REDACTED]

7-5

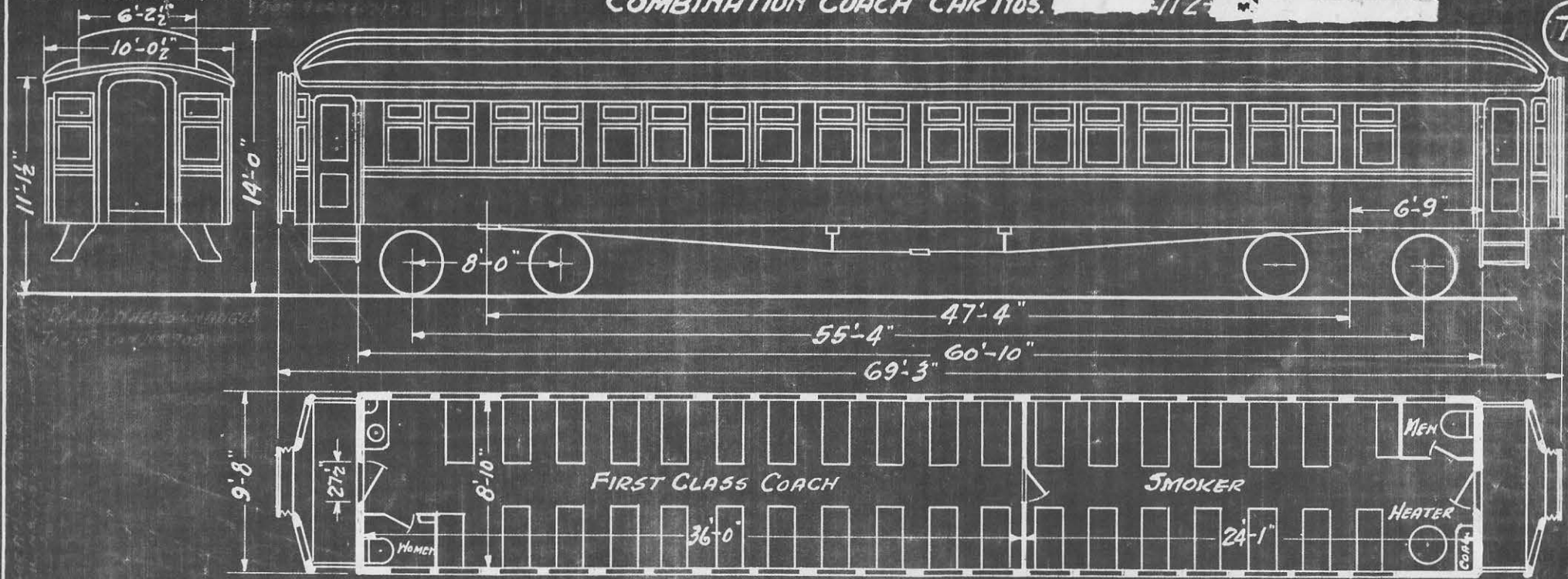

WEIGHT	76600 LBS.	TRUCK CENTERS	47'-4"	AIR BRAKES	14"x12" CYL.	FINISH EXTERIOR	GROOVED SHEATHING
LENGTH OVER FRAMING	60'-10"	TOTAL WHEEL BASE	55'-4"	AIR SIGNAL		INTERIOR	MANOGANY.
" " BUFFERS	69'-3"	TRUCK " "	8'-0"	HEATER	BAKER.	HEAD LINING	CANVAS
WIDTH " FRAMING	9'-8"	WHEELS STEEL	DIAM. 36"	HEATER PIPING	1 1/2" 475 FT.	LIGHTING	OIL
" " CROWN MLDG.	10'-0 1/2"	KIND OF TRUCK	METAL FACED	WATER SYSTEM	GRAVITY.	DRAFT GEAR	3-SPRING
SEATING CAPACITY	72.	JOURNALS	5"x9"			COUPLER	LONG SHANK 6 1/2" BUTT.



BUILT BY B. S. 1905  
 STEEL UNDERFRAME, SHEATHING, & VESTIBULE APPLIED 1922, 1924.

# FIRST CLASS COACH (LUNCH SERVICE) Nos 758, 759.

76

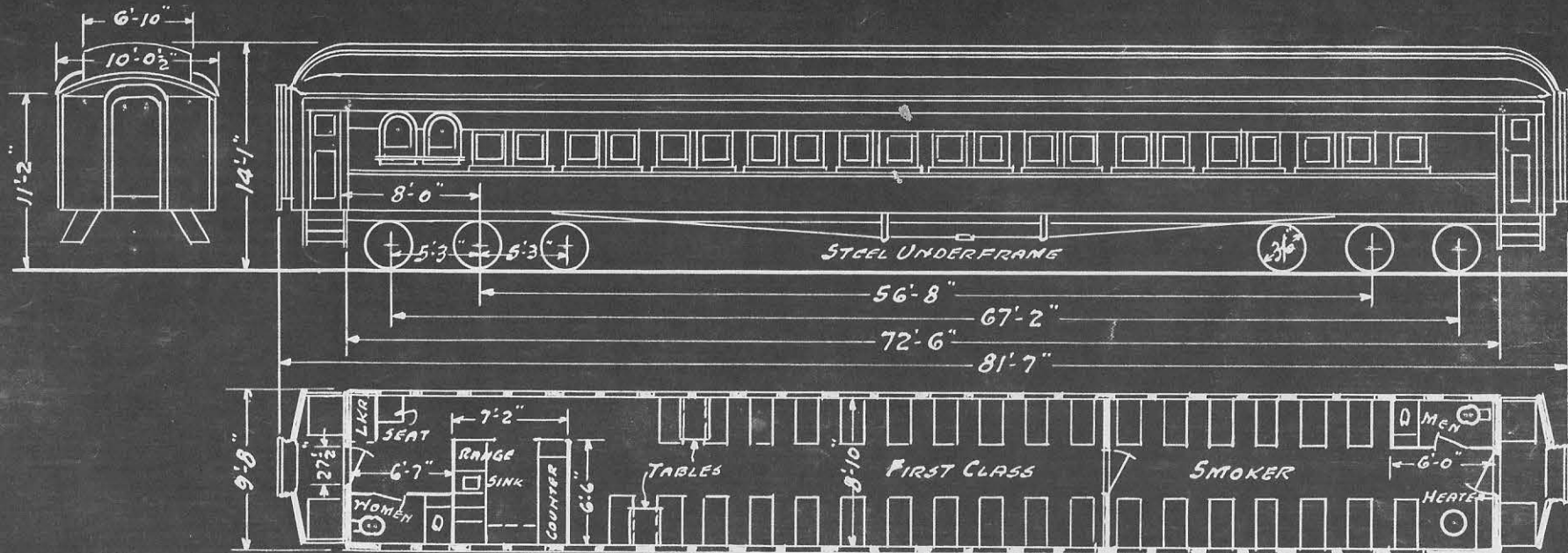

A.F.E. 19749, 46351.

DB

WEIGHT	141800 LBS.	TRUCK CENTERS	56'-8"	AIR BRAKE	2-16"x12" CYL.	FINISH EXTERIOR	STEEL SHEATHING
LENGTH OVER FRAMING	72'-6"	TOTAL WHEEL BASE	67'-2"	AIR SIGNAL		" INTERIOR	CUBAN MAHOGANY
" " BUFFERS	81'-7"	TRUCK- " "	10'-6"	HEATER	GOLD'S DOUBLE COIL	HEAD LINING	3 PLY VENEER PAINTED
WIDTH " FRAMING	9'-8"	KIND OF TRUCK	METAL FACED	HEATER PIPING	1 1/4" 620 FT.	LIGHTING	AXLE GEN. ELECTRIC
" " CROWN MLDG.	10'-0 1/2"	JOURNALS-SIZE	5"x9"	WATER SYSTEM	PRESSURE	DRAFT GEAR	MINER
SEATING CAPACITY	69.					COUPLER	SHORT SHANK 9 3/8" BUTT.

11-12-32. REV. 12-20-33. 5-26-43

BUILT BY PULLMAN CO. 1906.  
 STEEL UNDERFRAME, SHEATHG. & VEST. APPLIED. 1925, 26.  
 CHANGED FROM 1<sup>ST</sup> CL. COACH 1933.

# FIRST CLASS COACH (LUNCH SERVICE) Nos 760, 761.

77

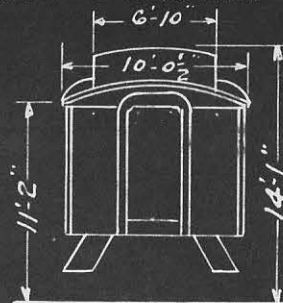

FORMERLY CAR No 913, 915.

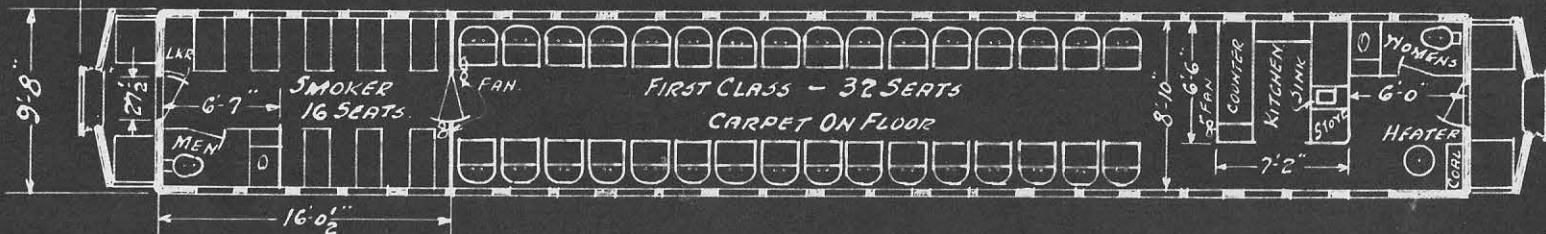
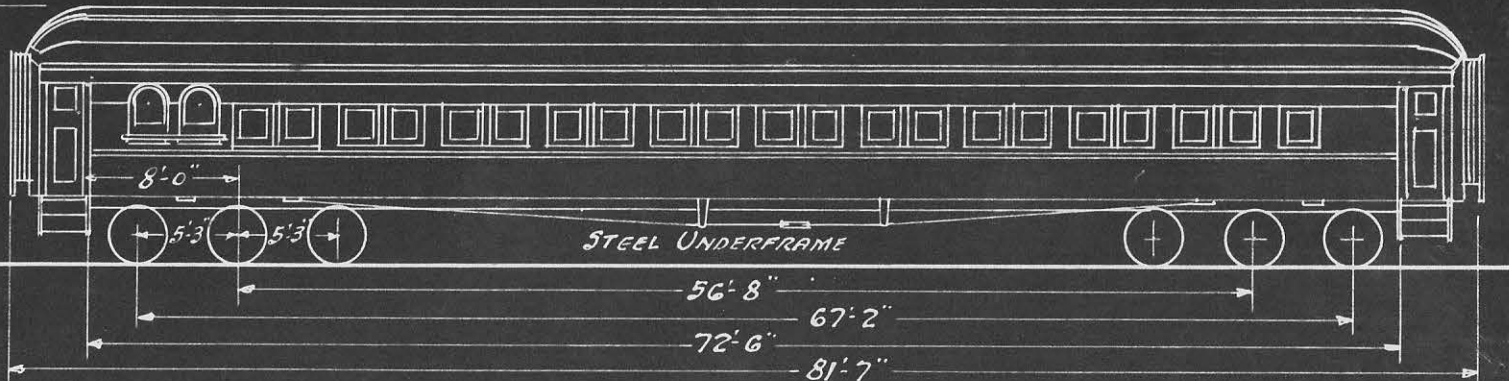

A.F.E. 19749, 37527, 46889.

DB

WEIGHT	147850 LBS.	TRUCK CENTERS	56'-8"	AIR BRAKE	2-16"x12" CYL.	FINISH EXTERIOR	STEEL SHEATHING
LENGTH OVER FRAMING	72'-6"	TOTAL WHEEL BASE	67'-2"	HEATER	GOLDS DOUBLE COIL	" INTERIOR	CUBAN MAHOGANY
" " BUFFERS	81'-7"	TRUCK	10'-6"	HEATER PIPING	1/4" - 620 FEET	HEAD LINING	3 PLY VENEER PAINTED
WIDTH " FRAMING	9'-8"	WHEELS - ROLLED STEEL	36" DIA.	WATER SYSTEM	PRESSURE	LIGHTING	AXLE GEN. - ELECTRIC
" " CROWN MLDG.	10'-0 1/2"	KIND OF TRUCK	METAL FACED	ELECTRIC FANS	THREE	DRAFT GEAR	A-5-P. - MINER
SEATING CAPACITY	48	JOURNAL SIZE	5"x9"	" " - EXHAUST	ONE	COUPLER	SHORT SHANK - 9 1/2" BUTT.

8-31-33. 5-26-43

BUILT BY PULL. 1906. & B.B.S. 1905.  
 STEEL UNDERFRAME, SHEATHING & YEST. APPLIED 1922, 23, 25, 26.

# FIRST CLASS COACH (LUNCH SERVICE) No 762 TO 767.

78

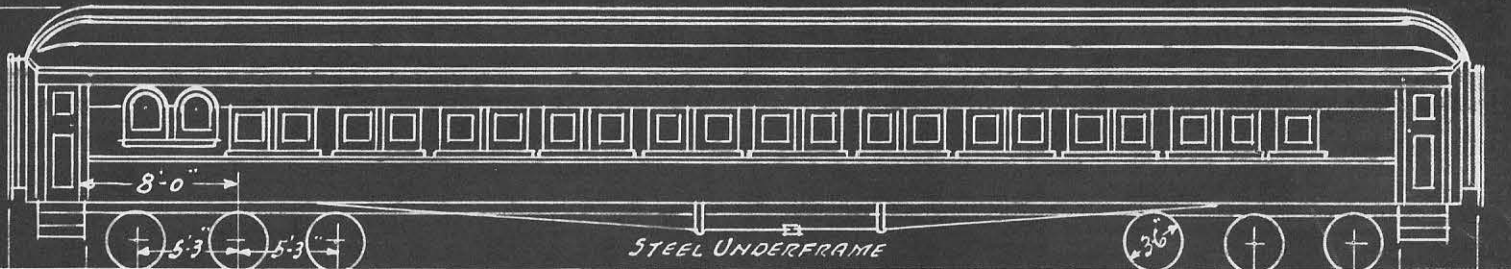
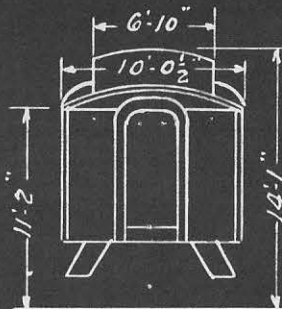

CHANGED TO LUNCH SERVICE 1933, 34  
 CAR No 762 FORMERLY 914

"	"	763	"	916
"	"	764	"	912
"	"	765	"	911
"	"	766	"	917
"	"	767	"	918

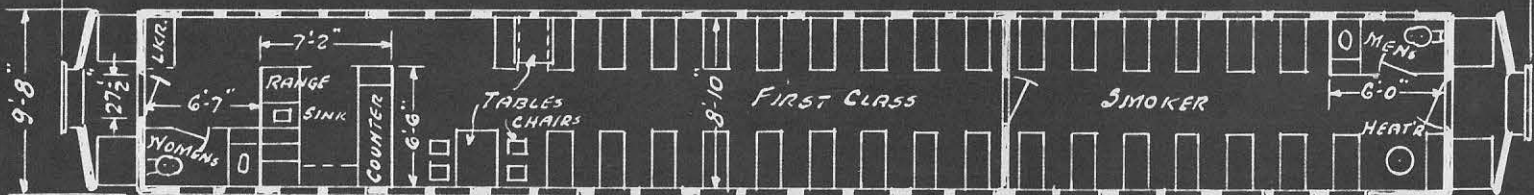
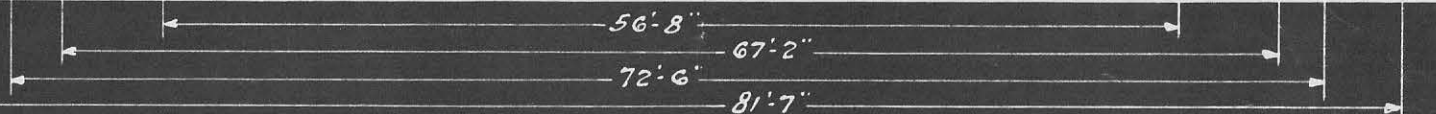

A.F.E. 19749, 47707, 47708, 47709.

DB

WEIGHT	146900 LBS.
LENGTH OVER FRAMING	72'-6"
" " BUFFERS	81'-7"
WIDTH " FRAMING	9'-8"
" " CROWN MLOG.	10'-0 1/2"
SEATING CAPACITY	68

TRUCK CENTERS	56'-8"
TOTAL WHEEL BASE	67'-2"
TRUCK - "	10'-6"
KIND OF TRUCK	METAL FACED.
JOURNALS - SIZE	5" x 9"

AIR BRAKE	2-16" x 12" CYL.
AIR SIGNAL	
HEATER	GOLD'S DOUBLE COIL.
HEATER PIPING	1 1/4" 620 FT.
WATER SYSTEM	PRESSURE

FINISH EXTERIOR	STEEL SHEATHING
" INTERIOR	CUBAN MAHOGANY
HEAD LINING	3 PLY VENEER PAINTED
LIGHTING	AXLE GEN. ELECTRIC
DRAFT GEAR	MINER A-5-P.
COUPLER	SHORT SHANK 9 1/8" BUTT.

12-20-33. Rev. 3-26-34. 5-26-43



BUILT BY B. & S. Co. 1910.

NEW	OLD
850	770
851	813
852	818
853	820
854	821
855	824
856	831
857	835
858	836
859	840
860	852
867	800
868	802
869	803
870	804
871	805
872	806
873	807
874	808
875	809
876	810
877	811
878	812
879	827
880	833

# FIRST CLASS COACH 850 TO 860, 867 TO 880.

79

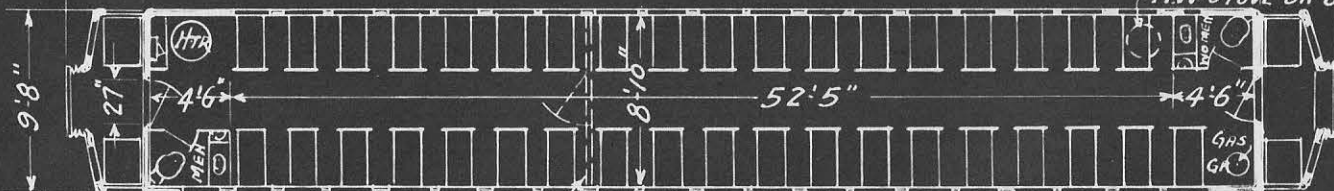
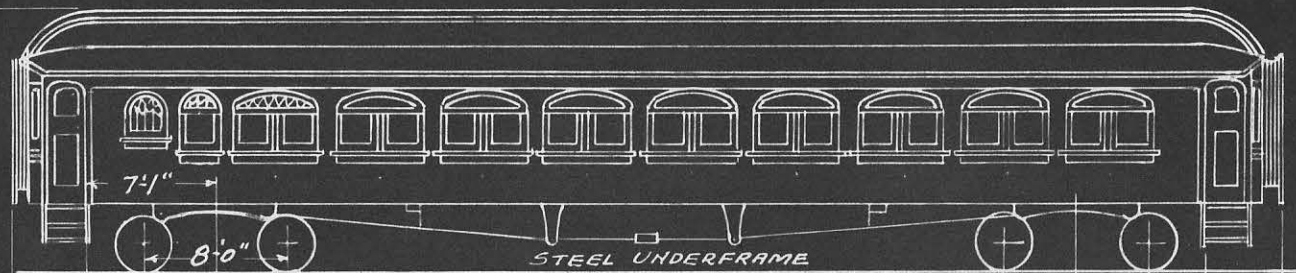
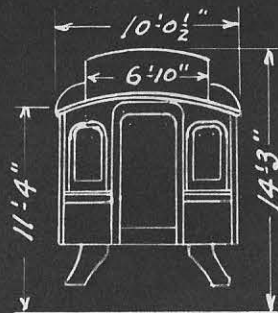

N.W. STOVE ON 852, 854, 871, 874, 876, 877, 878, 879.

PARTITIONS IN CAR NOS 867 TO 878.

AFE 65726.

PB.

WEIGHT	108600 LBS.
LENGTH OVER FRAMING	62'0"
" " BUFFERS	71'0"
WIDTH " FRAMING	9'8"
" " CROWN MLDG	10'0 1/2"
SEATING CAPY. 852, 854, 871, 874, 876 to 9,	72
" " OTHERS	74

TRUCK CENTERS	47'10"
TOTAL WHEEL BASE	55'10"
TRUCK " "	8'0"
WHEELS STEEL	36 1/2" DIA.
KIND OF TRUCK	METAL FACED.
JOURNALS	5" x 9"

AIR BRAKE	14" x 12" CYL
" SIGNAL	
HEATER, DBLE COIL, GOLD'S SYSTEM.	
HOT WATER & STEAM COMBINED.	
HEATER PIPING	1 1/4"
WATER SYSTEM	PRESSURE

FINISH, EXT.	GROOVED SHEATHING
" INT.	CUBAN MAHOGANY
HEAD LINING	3 PLY VENEER PAINTED
LIGHTING	GAS & ELECTRIC
DRAFT GEAR	FRICTION.
COUPLER	5' x 7" E' SWIV. BUTT.

BUILT BY B. & S. CO. 1910.

# COMBINATION COACH CAR NOS 861 TO 866

80

NEW No.	OLD No.
861	732
862	733
863	734
864	735
865	736
866	737

A.F.E 65726

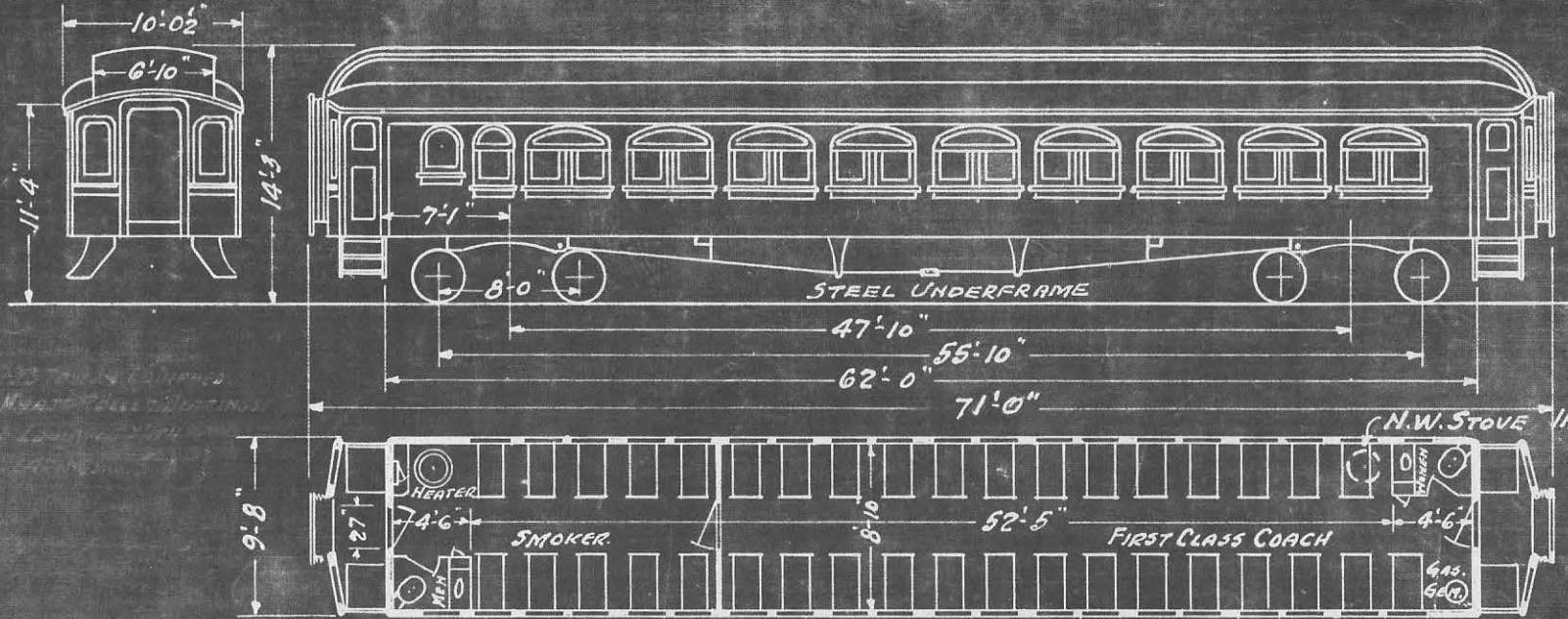

CHANGED IN 1911 & 12.

A.F.E 24583.

PB

WEIGHT	108600 LBS.	TRUCK CENTERS	47'-10"	AIR BRAKE	14"x12" CYL.	FINISH - EXTERIOR	GROOVED SHEATHING.
LENGTH OVER FRAMING	62'-0"	WHEEL BASE - TRUCK	8'-0"	" SIGNAL		" INTERIOR	CUBAN MAHOGANY.
" " BUFFERS	71'-0"	" " TOTAL	55'-10"	HEATER	DOUBLE COIL GOLD'S SYSTEM	HEAD LINING	3 PLY VENEER PAINTED.
WIDTH	9'-8"	WHEELS	STEEL TIRCO	HOT WATER & STEAM	COMBINED	LIGHTING	ELECTRIC & GAS.
" CROWN MLDG.	10'-02"	JOURNALS	SIZE	HEATER PIPING	14" FT.	DRAFT GEAR	FRICITION
SEATING CAPACITY	861, 864, 866 - 74.	KIND OF TRUCK	METAL FACED.	WATER SYSTEM	PRESSURE	COUPLER	5"x7" "E" SWIV. BUTT.
" "	862, 863, 865 - 72						

5-1-24, REV. 3-1-26, REV. 1-28-28, REV. 1-29-30, REV. 6-1-30, REV. 7-19-37, 5-26-43

REV. 5-36 11-22-39 12-15-41 5-26-43  
 5-1-24. FORMERLY 1<sup>ST</sup> CL. COACH. REV. 12-15-24. REV. 6-125. REV. 3-1-26. REV. 4-10-36

## COMBINATION COACH CAR Nos 881 to 886

81

BUILT BY B.&O. 1901.

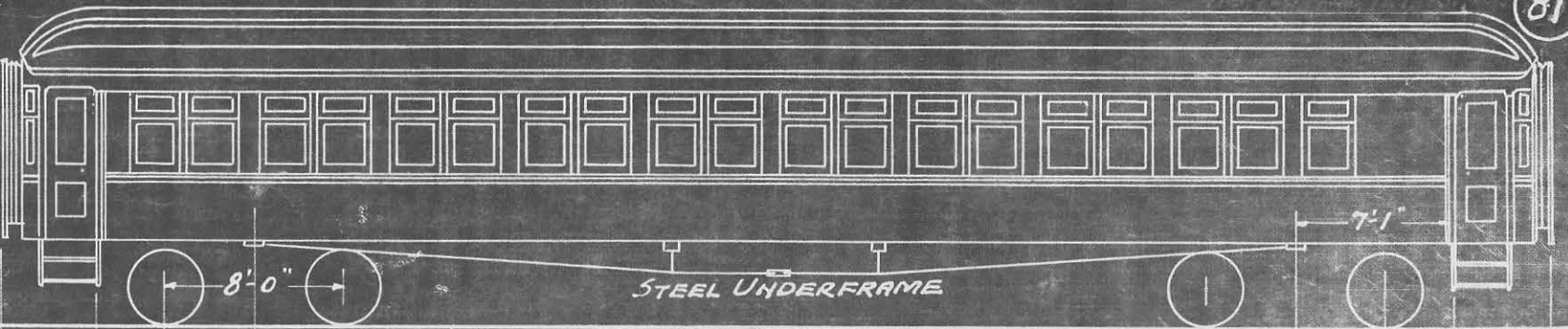
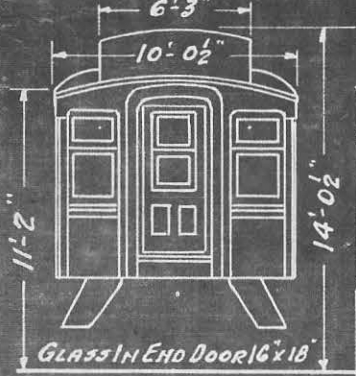

New Nos	Old Nos
881	714
882	717
883	718
884	719
885	723
886	725

RFE 65726

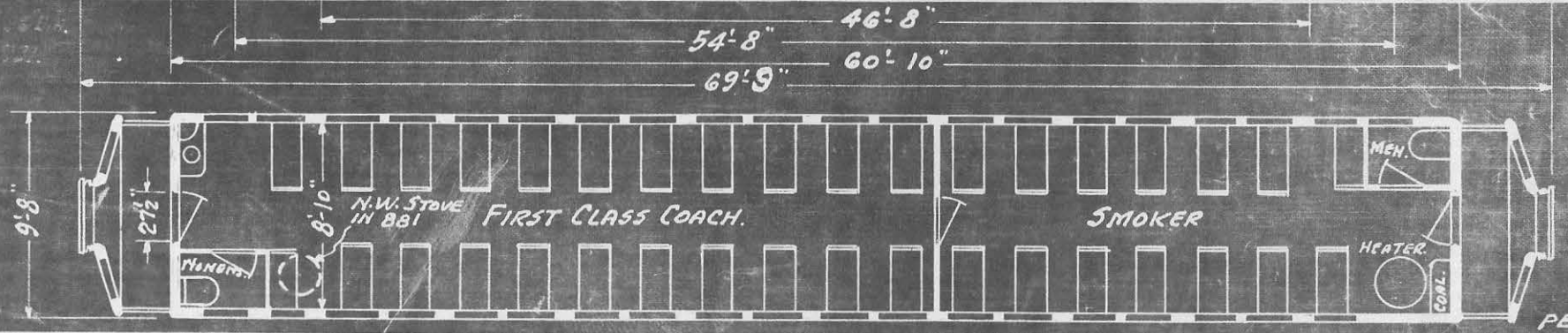

WEIGHT	88000 LBS.	TRUCK CENTERS	46'-8"	AIR BRAKE	14" x 12" CYL.	FINISH EXTERIOR	GROOVED SHEATHING
LENGTH OVER FRAMING	60'-10"	WHEELBASE-TRUCK	8'-0"	" SIGNAL		" INTERIOR	MAHOGANY.
" " BUFFERS	69'-9"	" " TOTAL	54'-8"	HEATER	x BAKER No. 5.	HEAD LINING	CANVAS PAINTED.
WIDTH " FRAMING	9'-8"	WHEELS	36 DIA.		SAFETY STEAM	LIGHTING	GAS & ELECTRIC.
" " CROWN M LDG.	10'-0 1/2"	JOURNALS SIZE	5" x 9"	HEATER PIPING	1 1/4" 550 FT.	DRAFT GEAR	FRICITION
SEATING CAPACITY	72.	KIND OF TRUCK	METAL FACED.	WATER SYSTEM	GRAVITY.	COUPLER	5"x7" "E" SWIV. BUTT.
" " 881	70.						



BUILT BY BARNEY & SMITH 1902. 887, 888, 891 to 898

1907-889, 890, 899.

# COMBINATION COACH Nos. 887 to 899

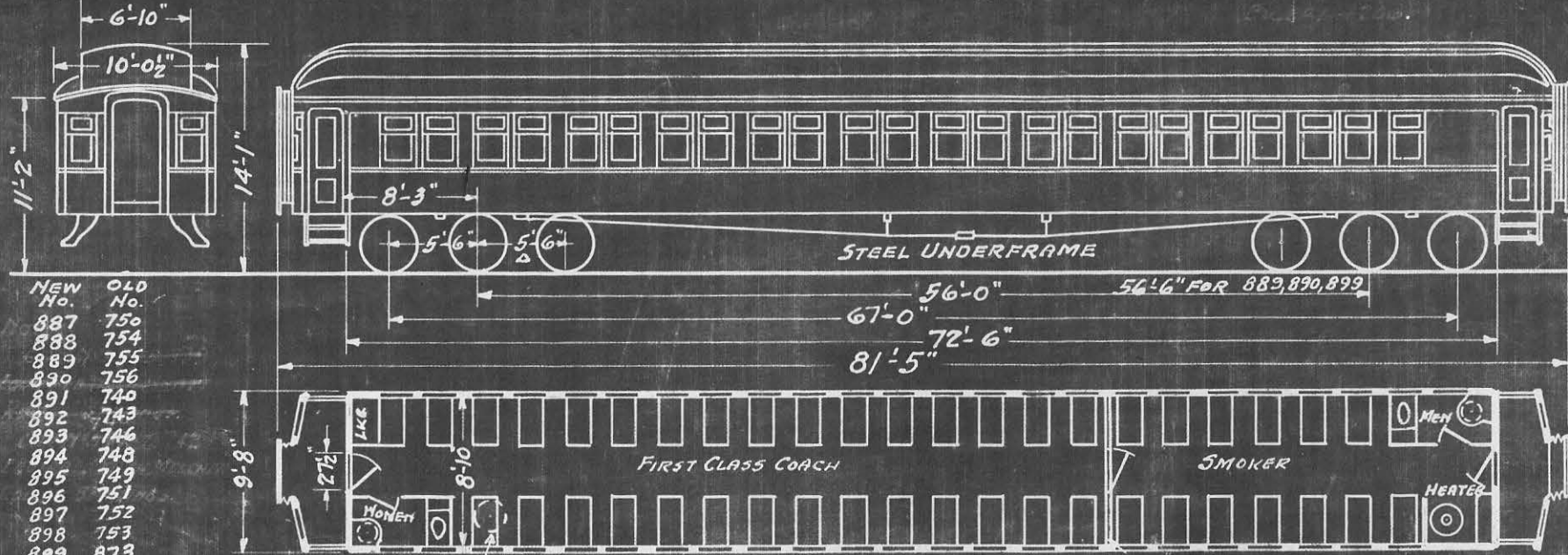

Δ 889, 890, 899 HAVE 10'-6" WHEEL BASE TRUCKS AND CIRCLE TOP WINDOWS.

NEW No.	OLD No.
887	750
888	754
889	755
890	756
891	740
892	743
893	746
894	748
895	749
896	751
897	752
898	753
899	873

AFE 65726

WEIGHT	116000 LBS.	TRUCK CENTERS	56'-0"	AIR BRAKES	14" x 12" CYL	FINISH EXTERIOR	GROOVED SHEATHING.
LENGTH OVER FRAMING	72'-6"	TOTAL WHEEL BASE	67'-0"	AIR SIGNAL	"	INTERIOR	MAHOGANY
" " BUFFERS	81'-5"	TRUCK " "	Δ 11'-0"	HEATER	⊗ BAKER'S	HEAD LINING	CANVAS PAINTED
WIDTH " FRAMING	9'-8"	WHEELS STEEL*	DIAM. 36"	HEATER PIPING	2 COIL STEEL HEATER	LIGHTING	GAS & ELECTRIC.
" " CROWN MLDG.	10'-0 1/2"	KIND OF TRUCK	METAL FACED.	WATER SYSTEM	14" 579 FT.	DRAFT GEAR	FRICTION
SEATING CAPACITY - OTHERS	86.	JOURNALS	5" x 9"			COUPLER	5" x 7" "E" SWIV. BUTT.
	892, 894, 897 84						

REV. 5-124. REV. 5-7-25. REV. 6-1-25. REV. 3-1-26. REV. 1-29-26. REV. 6-1-30. REV. 9-25-33

PB

REV. 9-30-33, REV. 3-26-34, 5-26-43  
 REV. 6-1-25, REV. 3-1-26, REV. 3-1-28, REV. 12-20-28, REV. 6-1-30, REV. 11-12-32, REV. 8-31-33,  
 FORMERLY CAR NOS. 4250 TO 4275 REV. 7-1-23, REV. 5-1-24, REV. 12-15-24.

BUILT BY BARNEY & SMITH 1905 - 900 TO 910

1907 - 930, 931.

# FIRST CLASS COACH NOS. 900 TO 910

PULLMAN CO 1906 - 912 TO 918.

STEEL UNDERFRAME, SHEATHING & VESTIBULE ADAPTED 1922, 23, 24, 25, 26, 28.

BRASS CONVERTER 930, 931.

83

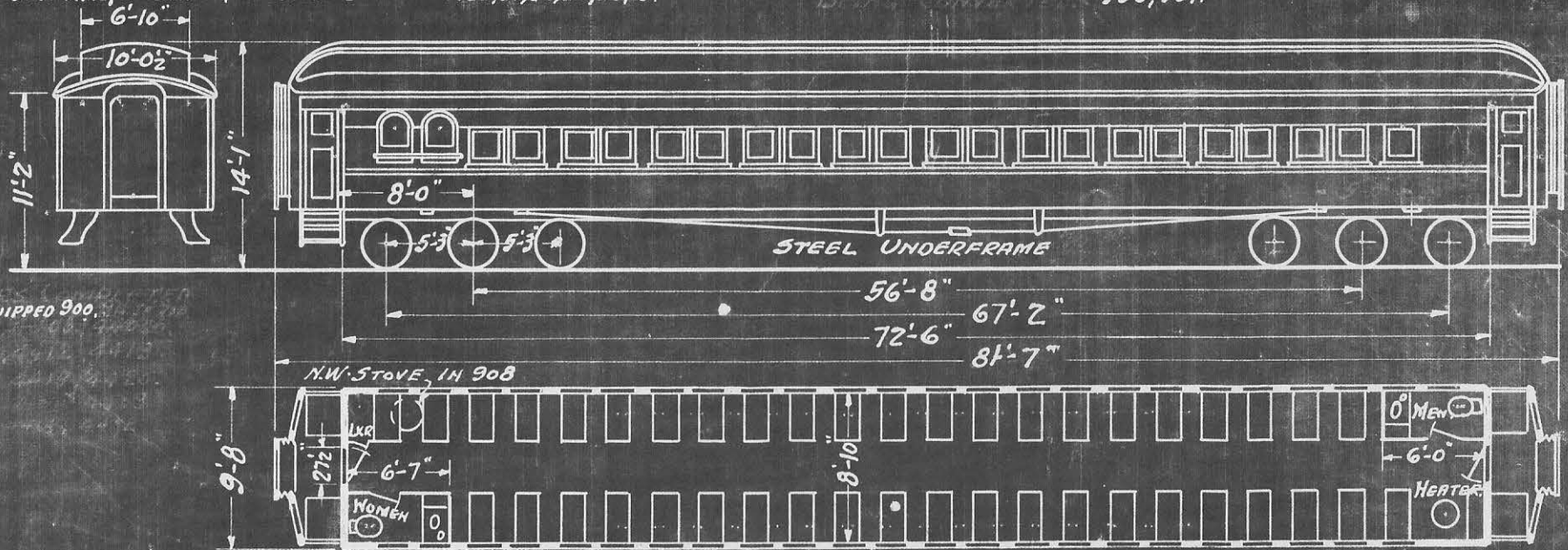

\* CARS EQUIPPED 900.

A.F.E 19749. 37527.

PB

WEIGHT	146200 LBS.	TRUCK CENTERS	56'-8"	AIR BRAKE	2-16x12 CYL. NEW YORK CO.	FINISH EXTERIOR	STEEL SHEATHING
LENGTH OVER FRAMING	72'-6"	TOTAL WHEEL BASE	67'-2"	AIR SIGNAL	" " " "	" INTERIOR	CUBAN MAHOGANY
" " BUFFERS	81'-7"	TRUCK	10'-6"	HEATER	GOLD'S DOUBLE COIL	HEADLINING	3 PLY VENEER PAINTED
WIDTH	9'-8"	WHEELS	STEEL DIAM 36"	HEATER PIPING	1 1/4" 620 FEET	LIGHTING	AXLE GEN* ELECTRIC
" " FRAMING	9'-8"	KIND OF TRUCK	METAL FACED	WATER SYSTEM	903, 4, 10, 30, 31 GRAVITY	DRAFT GEAR	MILNER
" " CROWN MLOG.	10'-0 1/2"	JOURNAL SIZE	5x9"	"	EXCEPT 903, 4, 10, 30, 31 PRESSURE	COUPLER	SHORT SHANK 9 3/8" BUTT.
SEATING CAPACITY	86						
"	708						
"	82						

BUILT BY B&S 1909.  
STEEL UNDERFRAME SHEATH. & VEST. 1923.

COACH NO. 911

84

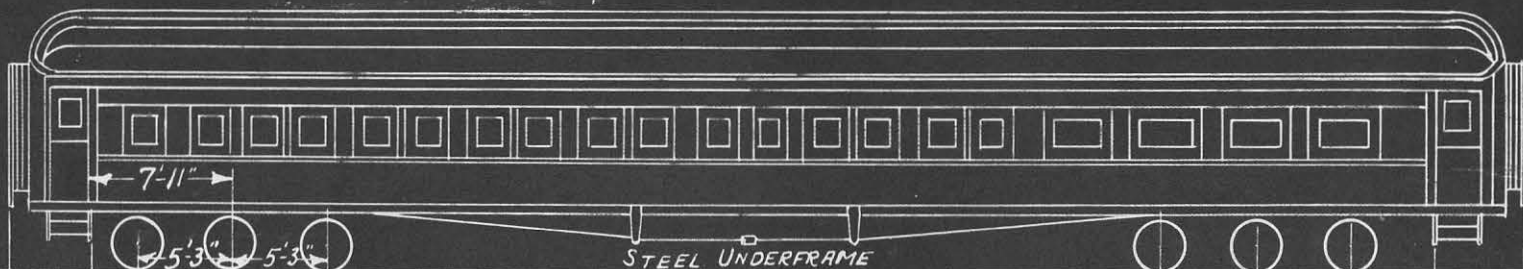
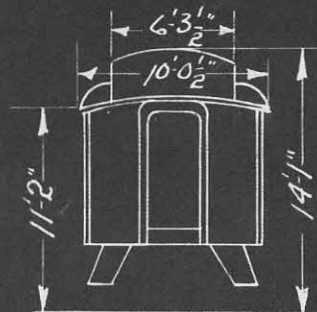

CHGD. TO PARLOR CAR 1928.  
" " 1<sup>ST</sup> CL COACH 1933.  
" " RES. SEAT " 1934.  
" " COACH 1937.

FORMERLY CAR 1106  
" " 1074

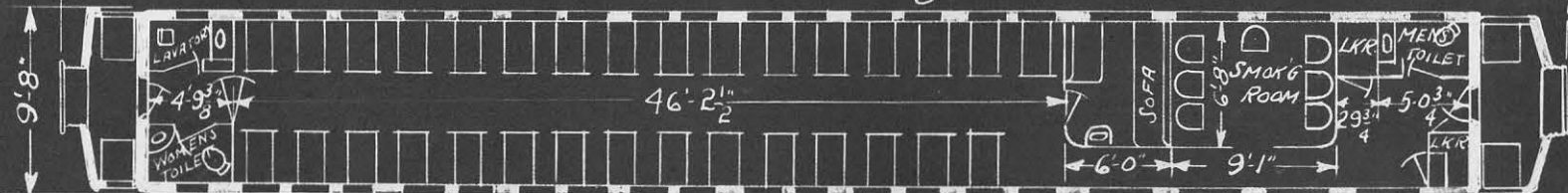

A.F.E. 20785, 36546, 52281.

PB

11-6-37. 5-26-43

WEIGHT	155,500 LBS.	TRUCK CENTERS	58'-6"	AIR BRAKE	2-16"x12" CYL.	FINISH EXTERIOR	STEEL SHEATHED.
LENGTH OVER FRAME	74'-6"	" WHEELBASE	10'-6"	AIR SIGNAL		" INTERIOR	VARIOUS WOOD
" " BUFFERS	83'-4 7/8"	" " TOTAL	69'-0"	EMPIRE DECK		HEAD LINING	3 PLY PAINTED
WIDTH " FRAMING	9'-8"	WHEELS ROLLED STEEL	36" DIA.	VAPOR HEAT		LIGHTING	AXLE GEN. ELEC.
" " CROWN MLDG.	10'-0 1/2"	KIND OF TRUCK	METAL FACED	CLASP BRAKE	SIMPLEX	DRAFT GEAR	MINER A-5-P-X
SEATING CAP.	75	JOURNAL SIZE	5"x9"	WATER SYSTEM	PRESSURE	COUPLER	SHORT SHANK 9 1/2" BUTT.
				SEATS	PUSH.		



BUILT BY B. & S. Co. 1910.  
 STEEL UNDERFRAME & SHEATHING APPLIED 1924.

COACH No 912

85

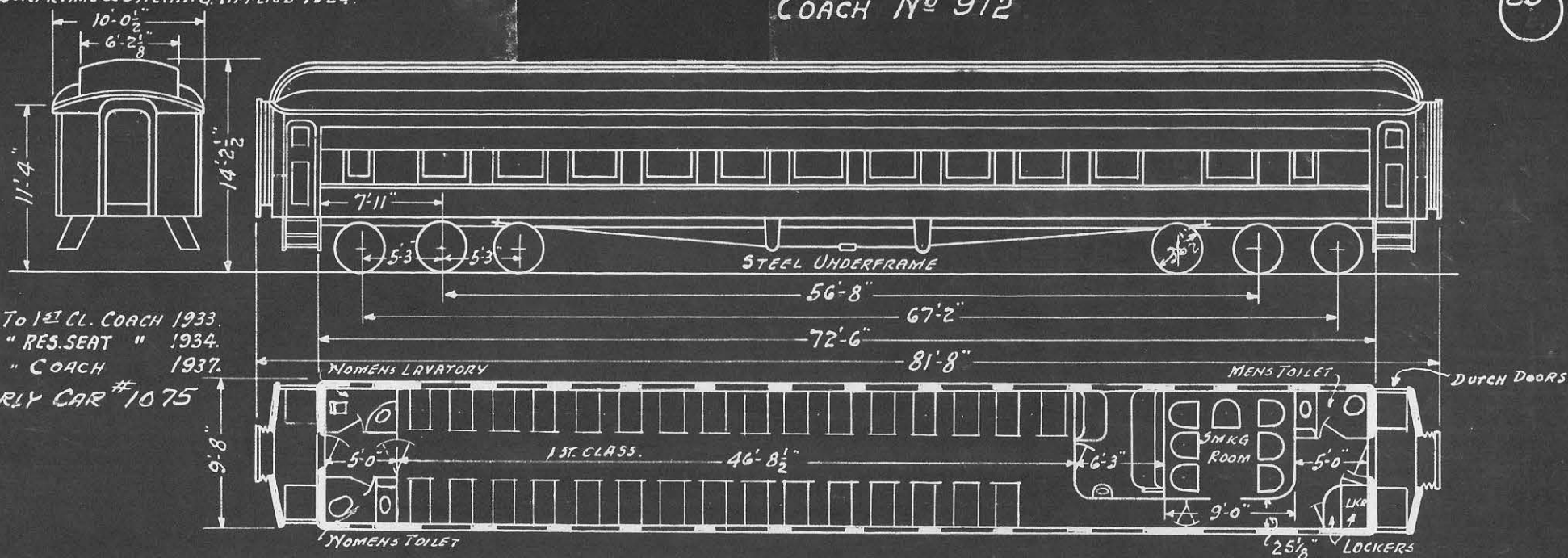

CHANGED TO 1st CL. COACH 1933.  
 " " RES. SEAT " 1934.  
 " " COACH 1937.  
 FORMERLY CAR #1075

A.F.E. 27635. 31066. 52281.

WEIGHT	148,860 LBS.	TRUCK CENTERS	56'-8"	AIR BRAKE	2-16x12" CYL.	FINISH - EXTERIOR	SHEET STEEL.
LENGTH OVER FRAMING	72'-6"	WHEEL BASE - TRUCKS	10'-6"	" SIGNAL		" INTERIOR	WOOD PAINTED.
" " BUFFERS	81'-8"	" - TOTAL	67'-2"	HEATING	VAPOR.	HEAD LINING	3PLY VENEER - PAINTED.
WIDTH " FRAMING	9'-8"	WHEELS - ROLLED STEEL	36 1/2" DIA.	WATER SYSTEM	AIR PRESSURE.	LIGHTING	AXLE GEN. - ELECTRIC.
" " CROWN MLDG.	10'-0 1/2"	JOURNAL SIZE	5x9"	CHAIRS	WICKER	COUPLER	SHORT SHANK - 9 1/2" BUTT.
SEATING CAPACITY	75.	KIND OF TRUCK	METAL FACED.	SEATS	PLUSH	DRAFT GEAR	A-B-PX. MINOR FRICTION.

9.25.33. REV. 4.13.35. REV. 11-8-37. 5-26-43

PB

BUILT BY B. & S. CO. 1910

COACH 913, 916

86

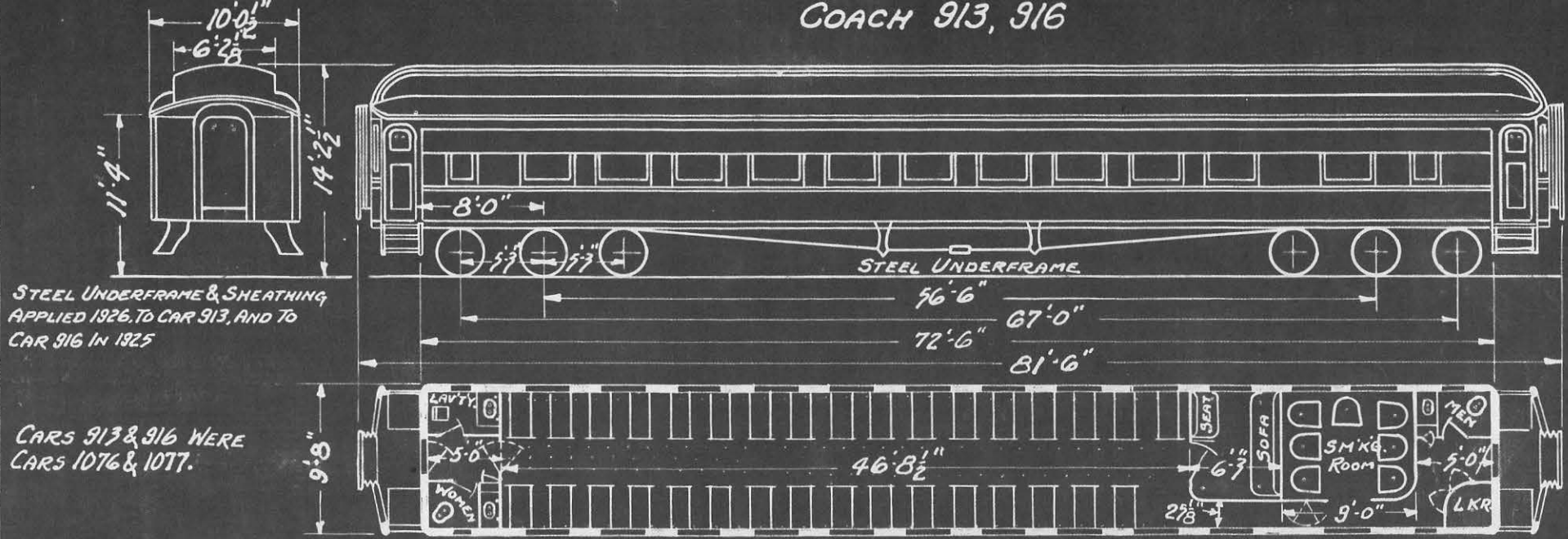

A.F.E. 56105

PB

WEIGHT	153,100 LBS	TRANSOM CENTERS	56'-6"	AIR BRAKE	2-16" x 12" CYL	FINISH EXTERIOR	SHEET STEEL
LENGTH OVER FRAMING	72'-6"	TOTAL WHEEL BASE	67'-0"	AIR SIGNAL		INTERIOR	WOOD
LENGTH OVER BUFFERS	81'-6"	TRUCK WHEEL BASE	10'-6"	HEAT	VAPOR	HEAD LINING	3 PLY VENEER PAINTED
WIDTH OVER FRAMING	9'-8"	WHEELS, STEEL	DIAM. 36 1/2"	WATER SYSTEM	AIR PRESSURE	LIGHTING	AXLE GEN. ELECTRIC
WIDTH OVER CROWN M'L'DG.	10'-0 1/2"	KIND OF TRUCK	METAL FACED	HEATER PIPING	1 1/4"	DRAFT GEAR	MINER
SEATING CAPACITY	79	JOURNALS, SIZE	5" x 9"	EMPIRE DECK		COUPLER	SHORT SHANK 9 3/8" BUTT.
							WIDE VESTIBULES.

5-26-43

BUILT BY B. & S. CO. 1910.  
 STEEL UNDERFRAME & SHEATHING APPLIED 1925

- FIRST CLASS COACH NO. 914 915

87

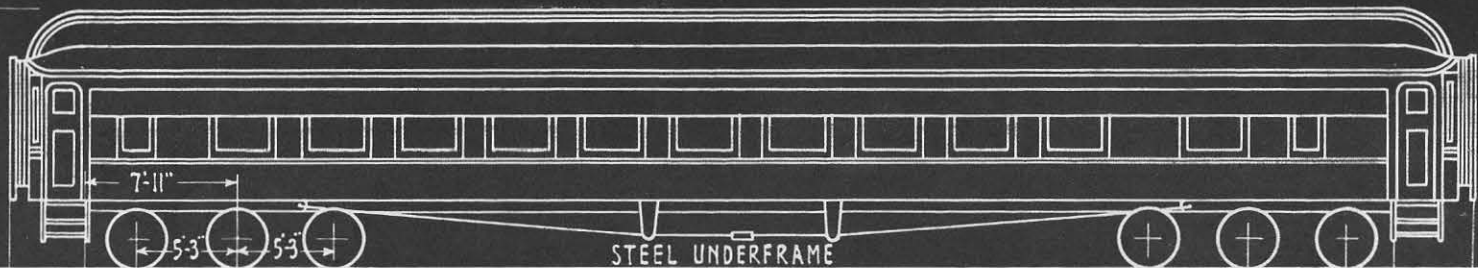
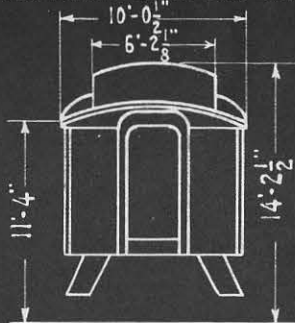

CHANGED TO 1ST. CLASS COACH 1933  
 OLD NO. 1078 & 1079  
 CHG'D. TO 914, 915, 1938

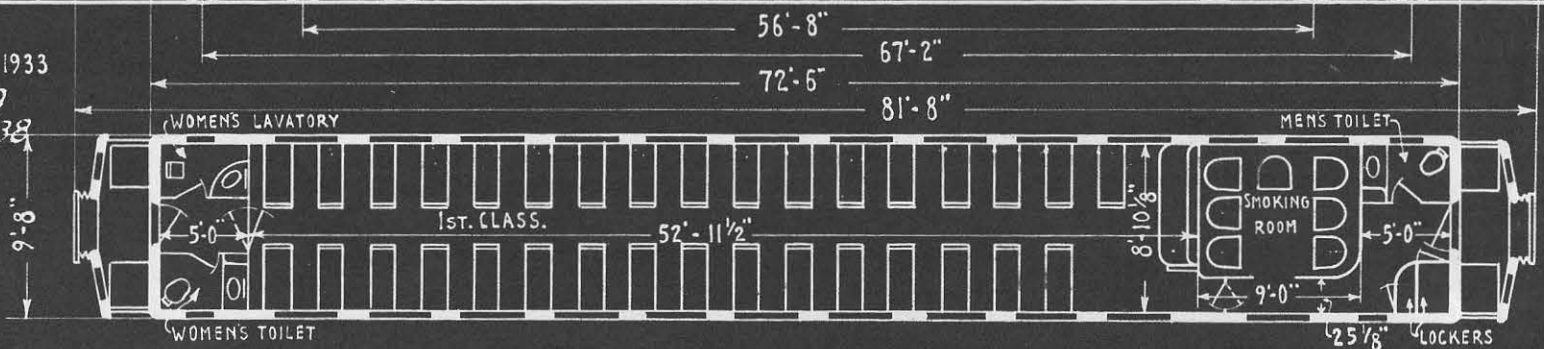

A.F.E. 25478, 27635.

PB

WEIGHT.....	154500 LBS.	TRUCK CENTERS.....	56'-8"
LENGTH OVER FRAMING.....	72'-6"	WHEEL BASE-TRUCKS.....	10'-6"
" " BUFFERS.....	81'-8"	" " -TOTAL.....	67'-2"
WIDTH " FRAMING.....	9'-8"	WHEELS - ROLLED STEEL.....	36 1/2" DIA.
" " CROWN MLDG.....	10'-0 1/2"	JOURNAL SIZE.....	5" x 9"
SEATING CAPACITY.....	76	KIND OF TRUCK.....	METAL FACED

AIR BRAKE.....	2-16" CYL.....	NEW YORK.
" SIGNAL.....	"	"
HEATING.....	VAPOR	
WATER SYSTEM.....	AIR PRESSURE	

FINISH EXTERIOR.....	SHEET STEEL
" INTERIOR.....	WOOD PAINTED.
HEAD LINING.....	3 PLY VENEER PAINTED.
LIGHTING.....	AXLE GEN.....
COUPLER.....	SHORT SHANK.....
DRAFT GEAR.....	A-5-P.....

9-21-33, 1-22-38, 5-26-43





BUILT BY B. & O., 1910  
 STEEL UNDERFRAME, SHEATHING & VESTIBULE APPLIED 1925, 1926.

# FIRST CLASS COACH Nos 920 to 927.

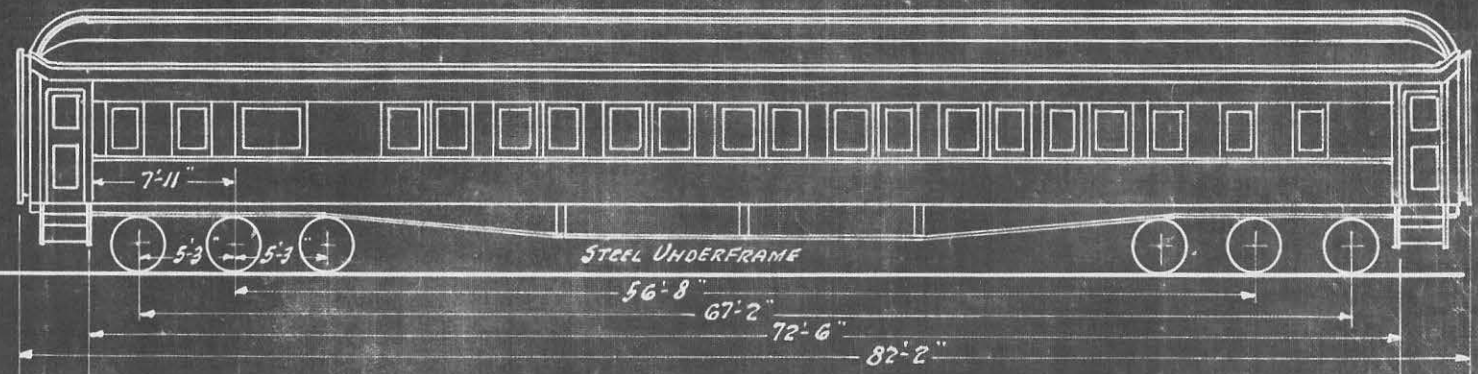
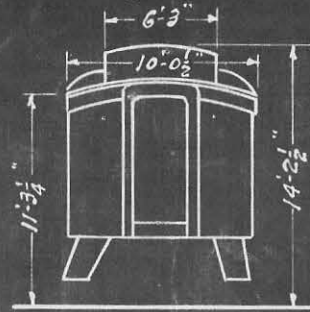

x 922, 927  
 HAVE 5x7 "E" SWIV. BUTT CLR.

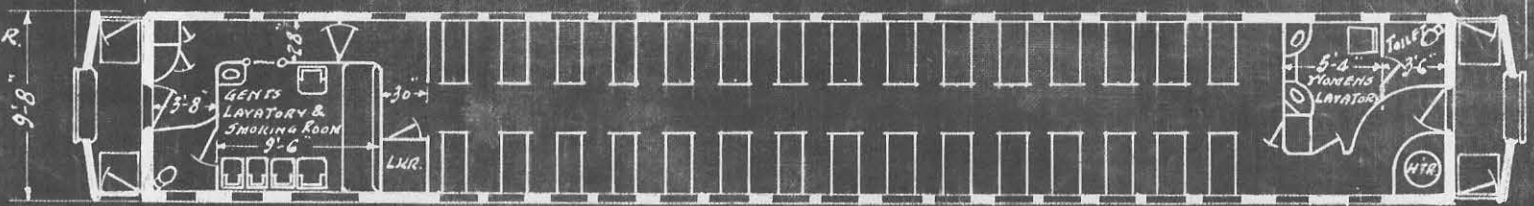

A.F.E. 30085, 30621.

PB

WEIGHT	167000 LBS.	TRUCK CENTERS	56'-8"	AIR BRAKE	2-14x12" CYL. NEW YORK	FINISH-EXTERIOR	SHEET STEEL
LENGTH OVER FRAMING	72'-6"	WHEEL BASE - TRUCK	10'-6"	" SIGNAL	" "	" -INTERIOR	WOOD-ORIENTAL LTD. COLOR.
" " BUFFERS	82'-2"	" " -TOTAL	67'-2"	HEATER	BAKER	HEAD LINING	3 PLY VENEER
WIDTH	9'-8"	WHEELS	ROLLED STEEL 36" DIA.	HEATER PIPING	14" FT.	LIGHTING	AXLE GEN. ELECTRIC.
" " CROWN MLDG.	10'-0 1/2"	KIND OF TRUCK	METAL FACED.	VAPOR HEAT.		DRAFT GEAR	MINER
SEATING CAPACITY	70	JOURNALS SIZE	5" x 9"	CLASP BRAKE	SIMPLEX	COUPLER	x SHORT SHANK 9 1/2" BUTT.
				WATER SYSTEM	PRESSURE		

REV. 5-13-38. 5-26-43  
 3-1-26. REV. 10-20-26. REV. 11-28-20. REV. 3-9-29. REV. 3-11-29. REV. 6-1-30. REV. 4-14-39

5-1-24. Rev. 9-24-24. Rev. 6-1-25. Rev. 7-30-25. Rev. 3-1-26. Rev. 10-20-26. Rev. 6-1-30. 5-26-43

BUILT BY B. & O. 1907.  
STEEL UNDERFRAME & SHEATHING APPLIED 1925

# FIRST CLASS COACH No 928

90.

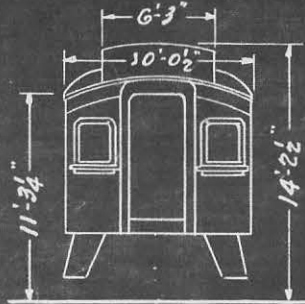

928 FORMERLY 919

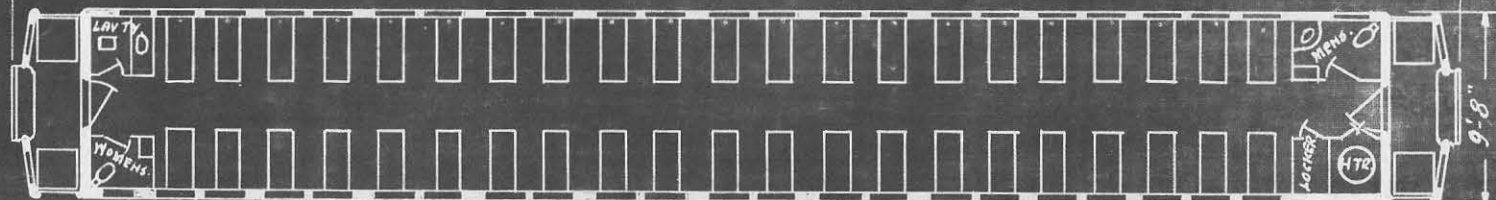
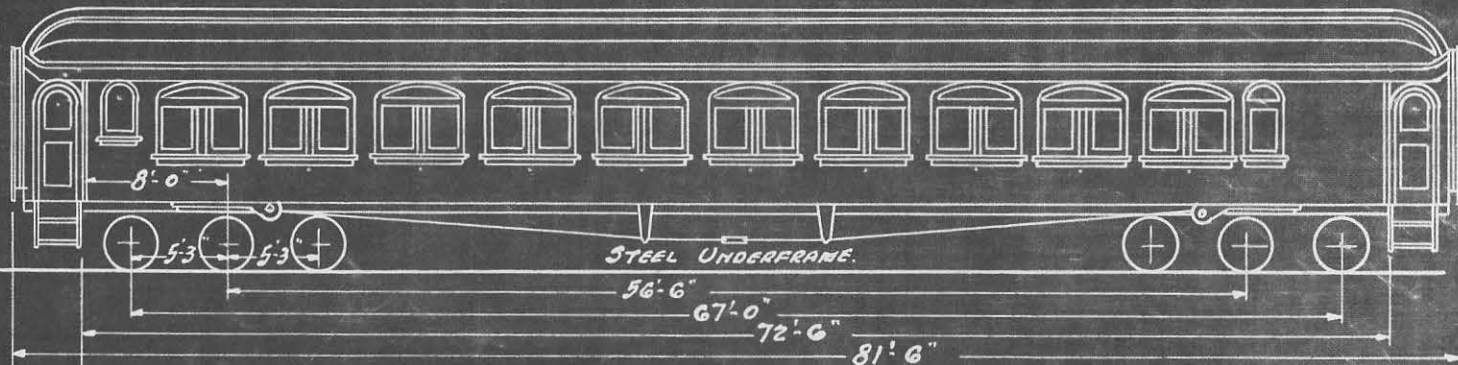

FORMERLY SLEEPER No 8213, A.F.E 26736.

WEIGHT	158100 LBS.	TRUCK CENTERS	56'-6"	AIR BRAKE	2-14" CYL. — NEW YORK	FINISH, EXTERIOR	SHEET STEEL.
LENGTH OVER FRAMING	72'-6"	WHEELBASE-TRUCK	10'-6"	" SIGNAL	" "	" INTERIOR	" "
" " BUFFERS	81'-6"	" " -TOTAL	67'-0"	HEATER	BAKER	HEAD LINING	" "
WIDTH " FRAMING	9'-8"	WHEELS STEEL TIRED	36" DIA.	VAPOR HEAT.		LIGHTING	AXLE GEN. — ELECTRIC.
" " CROWN MLDG.	10'-0 1/2"	JOURNALS SIZE	5" x 9"	CLASP BRAKE	SIMPLEX.	DRAFT GEAR	MINER
SEATING CAPACITY	84.	KIND OF TRUCK	METAL FACED			COUPLER	SHORT SHANK — 9 1/2" BUTT.

FB



BUILT BY PULLMAN MFG. CO. 1937.

FIRST CLASS AIR CONDITIONED STEEL COACHES 938 TO 949.

91

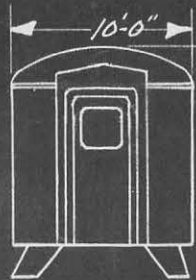

13'-6"

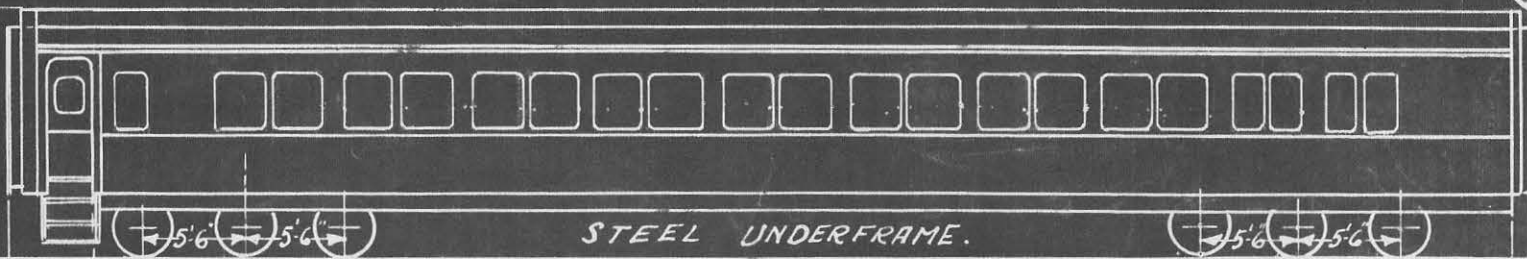

STEEL UNDERFRAME.

5'-6" 5'-6"

5'-6" 5'-6"

69'7 1/2" 58'7 1/2"

78'-6 1/2"

84'-1 1/2" OVER BUFFERS.

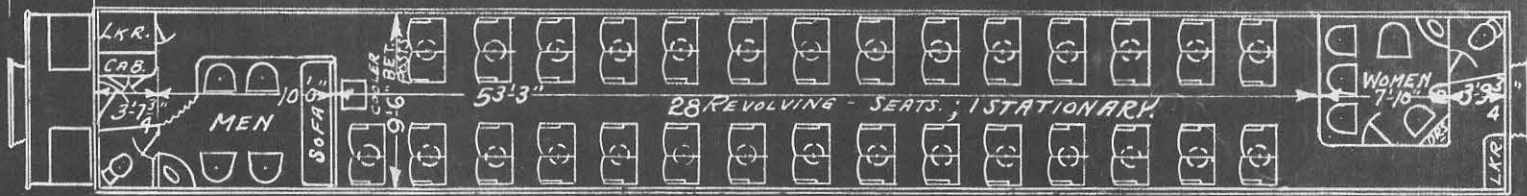

L.R. CAB.

MEN

SOFA

9'-6" V-BELT

53'-3"

28 REVOLVING - SEATS; 1 STATIONARY.

WOMEN

L.R.

A.F. E. 52276.

WEIGHT	LBS.	134,200
LENGTH OVER FRAMING		78'-6 1/2"
" " BUFFERS		84'-1 1/2"
WIDTH " FRAMING		10'-0"
TOTAL HEIGHT FROM TOP OF RAIL		13'-6"
SEATING CAPACITY		58

TRUCK CENTERS		58'-7 1/2"
TRUCK WHEELBASE		11'-0"
TOTAL		69'-7 1/2"
KIND OF TRUCK		CAST STEEL
WHEELS		ROLLED STEEL 36" DIA.
JOURNALS		5" x 9"
ROLLER BEARINGS		AM. ST. FOLS.

AIR BRAKE		4-10x8" CYLS. TRUCK MD.
AIR SIGNALS		"
VAPOR HEAT		THERMOS. CONT.
RADIATION		VULCUM FINN TYPE
CLASP BRAKES		SIMPLEX
AIR CONDITIONING		PULLMAN MECH.
" " DUCT		CENTER
WATER SYSTEM		PRESSURE

FINISH EXTERIOR		STEEL SHEATH.
" INTERIOR		STEEL PAINTD.
HEAD LINING		FLAT STEEL CEILING
GEN.		AXLE 7 1/2 KW. V-BELT DRIVE
LIGHTING		INDIRECT. ELECTRIC
DRAFT GEAR		A-5 X B MINER
COUPLER		SHORT SHANK 9 1/2 BUTT.
VEST. DIAPHRAM		FOWLER SPRINGS
BUFFER		MINER B-10-X

10-5-37. 12-21-37. 4-24-40 5-26-43

#B

BUILT BY B. & S. CAR CO. 1914.  
AIR CONDITIONED 1935. - 41336

# FIRST CLASS STEEL COACH 950 TO 961. <sup>Δ</sup>962, 963, 965, 966

AIR CONDITIONED.

92

4-12-35. 5-15-36. REV. 5-2-41 12-15-41 11-12-42 5-26-43

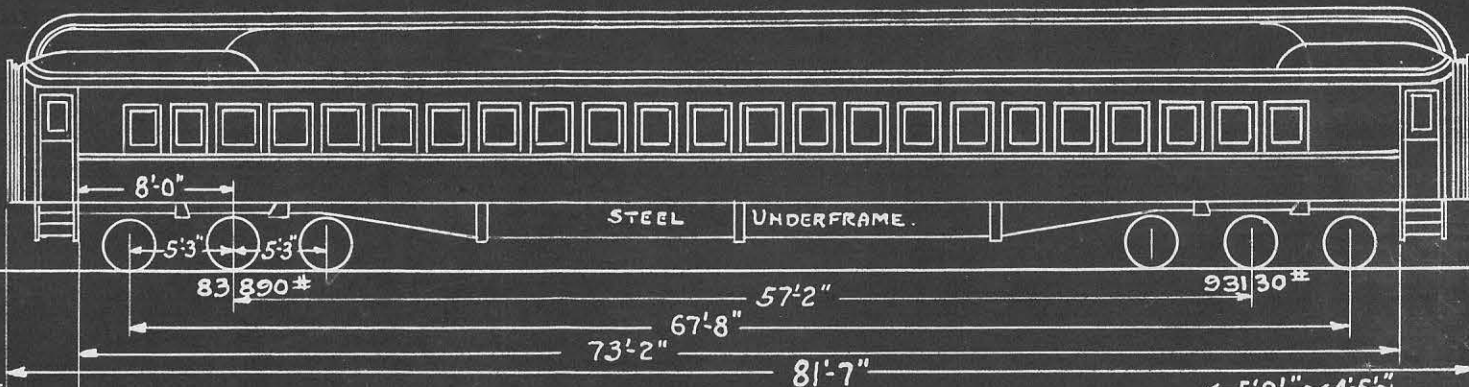
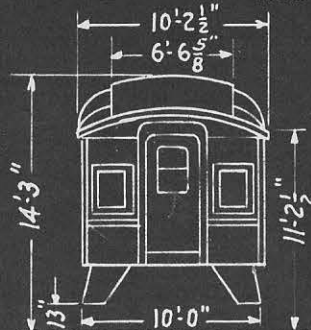

\* CARS EQUIPPED WITH MINER DRAFT GEAR A-5-X MINER BUFFER B-10-X TYPE "D" COUPLER 5x7" SHANK-9 1/2" BUTT CAR. NOS ~~950~~, 958, 961, 962, ~~963~~, 965

+ CAR 950 - MINER DRAFT GEAR & SWIVEL BUTT COUPLER "E" 952, 955, 956, 957, 959, ~~960~~, 966

A CARS EQUIPPED WITH WESTINGHOUSE FRICTION DRAFT GEAR + SWIVEL BUTT COUPLER 963, 953 965

A.F.E. 25822, 49137, 50489.

Δ 955, 956 HAVE 10" x 8" TRUCK MOUNTED AIR BR. CYLS.

Δ 955, 956 HAVE C.S. TRUCKS OF 11" x 10" WIA. BASE 966 HAS WELDED STEEL TRUCK 10 1/2"

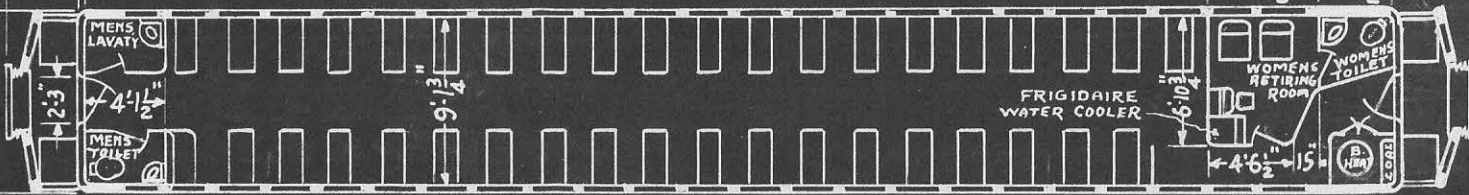

PB

WEIGHT - WITH ICE & BAT. 177 020*	TRUCK CENTERS 57'-2"	AIR BRAKE 18"x12" CYL. @ NEW YORK	FINISH - EXTERIOR SHEET STEEL
LENGTH OVER FRAMING 73'-2"	WHEEL BASE - TRUCK ± 10'-6"	" SIGNAL " "	" - INTERIOR " "
" " BUFFERS 81'-7"	" " - TOTAL 67'-8"	HEATER GOLD'S DOUBLE COIL	HEAD LINING 3/16" AGASOTE
WIDTH " FRAMING 10'-0"	WHEELS - STEEL 36" DIA.	" PIPING 1 1/4"	LIGHTING - AXLE GEN. - ELECTRIC
" " CROWN ML'DG 10'-2 1/2"	JOURNALS SIZE 5" x 9"	RESERVOIRS 16"x42" & 22"x54"	DRAFT GEAR*± FRICTION
SEATING CAPACITY 78	KIND OF TRUCK ± METAL FACED.	WATER SYSTEM PRESSURE	COUPLER*±A SWIVEL 6 1/2" BUTT
AXLE GEN. DRIVE " DICK"	VAPOR HEAT THERMOSTATIC CONTROL	AIR COOLING SYSTEM ICE	CLASP BRAKE SIMPLEX.

SIDE DOOR.

11-22-37 11-22-39 4-24-40 12-15-41 11-12-42 5-26-43

BUILT BY B&S. CAR Co. 1914.  
AIR COND. NEWTRUCKS REMODELED 1937.

FIRST CLASS STEEL COACH NOS. 964, 967 to 973,  
AIR CONDITIONED

93

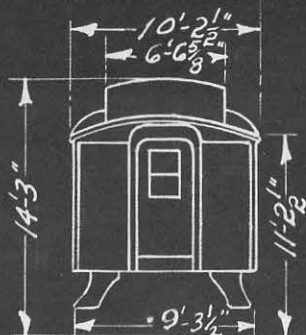

△ WEST'USE GEAR & SWIVEL BUTT C PLR- 969, 970, 972.  
○ MINER GEAR & SWIVEL BUTT C PLR 964, 968,

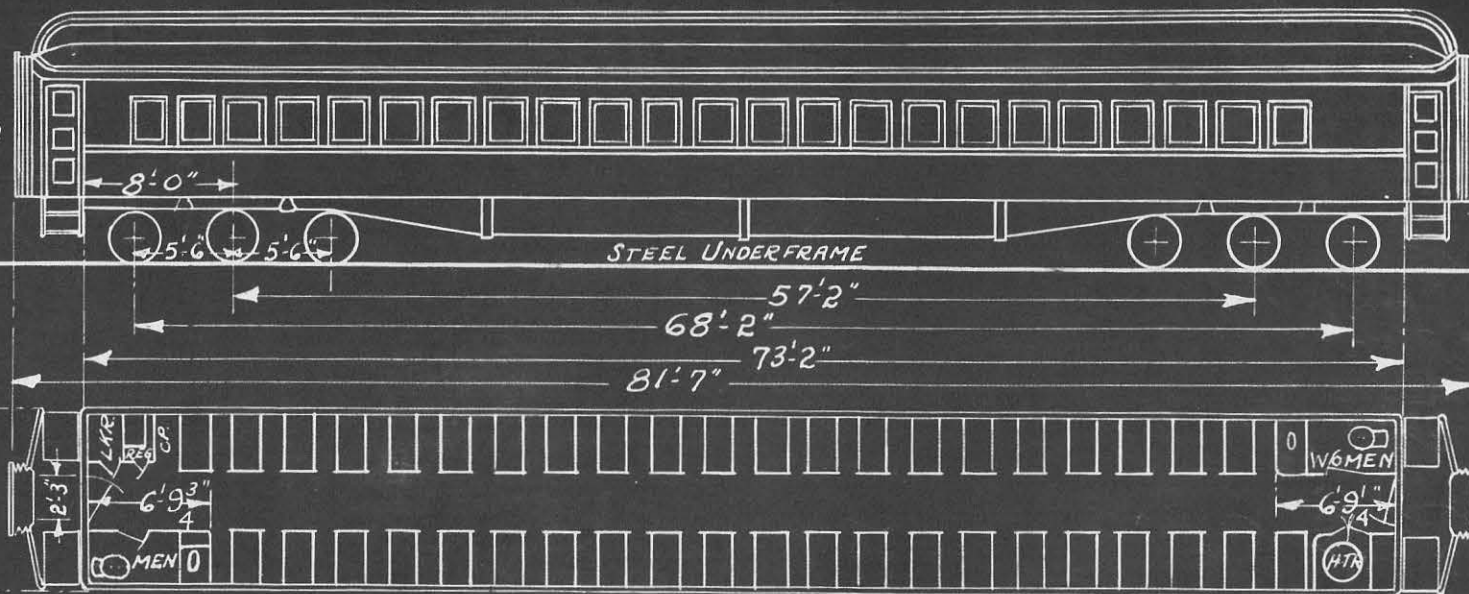

AFF 52277&53111

PB

WEIGHT LIGHT	Lbs. 175,000	TRUCK CENTERS	57'-2"	AIR-BRAKES	4-10"x8" CYL. TR. MTD.	OUTSIDE FINISH	STEEL
" BATT. & ICE-LOADED	184,000	" WHEEL BASE	11'-0"	HEATER	GOLD'S DOUBLE COIL 1 1/4" PIPE	INSIDE	"
LENGTH OVER BUFFERS	81'-7"	TOTAL "	68'-2"	WATER SYSTEM	PRESSURE	HEAD LINING	FLAT STEEL CEILING
" Posts	73'-2"	WHEELS	ROLLED STEEL 36" DIA.	AIR COND.	ICE ACTIVATED.	LIGHTING	AXEL GEN. - ELEC.
WIDTH	" ANGLES 10'-0"	KIND OF TRUCK	CAST STEEL	" DUCT	SINGLE CENTER	DRAFT GEAR	△ - FRICTION
" CROWN MLDG.	10'-2 1/2"	JOURNALS	5"x9"	VAPOR HEAT	FINN RADIATION	COUPLER	△ - SWIVEL 9 1/8" BUTT.
SEATING CAPACITY	85	TRUCK MTD. GEN. CARS	967 to 973	CLASP BRAKES	SIMPLEX.		

CENTER DUCT



OCT. 1, 37, 11-22-39 4-24-40 REV. 5-2-41 12-15-41 - 11-12-42 5-26-43

BUILT BY B.S. CAR CO. 1914  
AIR COND. NEW TRUCKS REMODELED 1937.

# CAFE COACH STEEL NOS. 974, 975, 976, AIR CONDITIONED

94

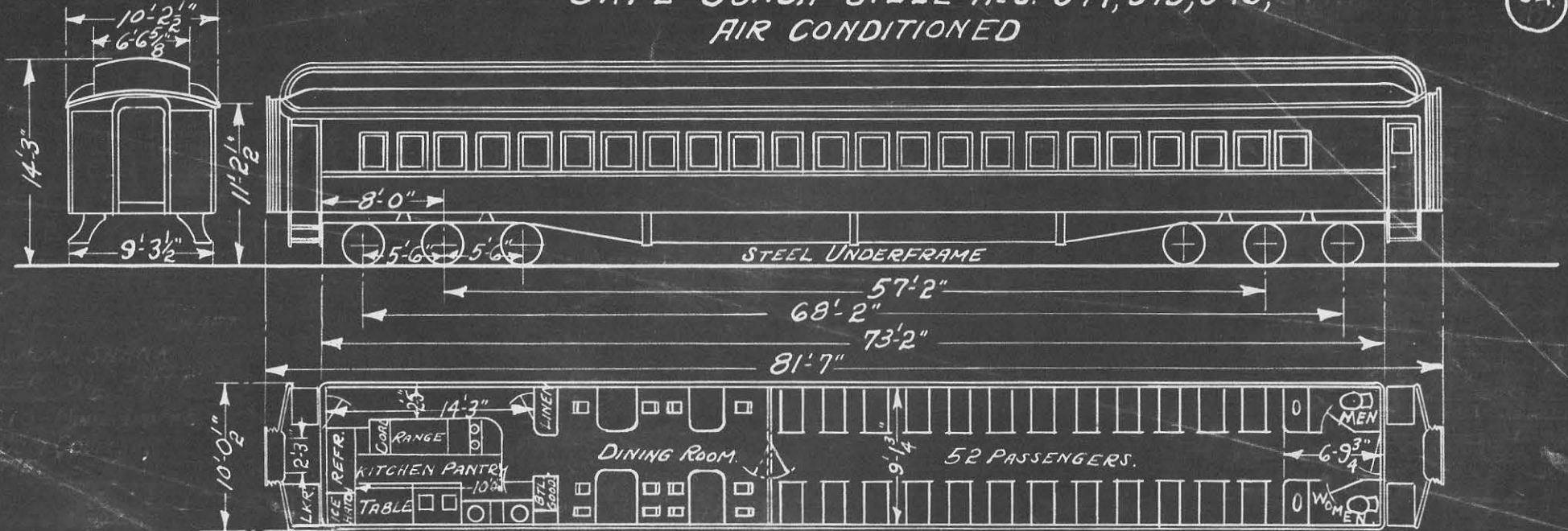

A.F.E. 52277, & 53111

PB

WEIGHT — 184,200 — LBS.	TRUCK CENTERS — 57'2"	AIR BRAKES — 4-10"x8" CYL. TR. MTD.	OUTSIDE FINISH — — STEEL
" BATT. & ICE LOADED	" WHEEL BASE — 11'0"	CLASP BRAKES — SIMPLEX	INSIDE " " "
LENGTH OVER BUFFERS — 81'7"	TOTAL " " — 68'2"	WATER SYSTEM — PRESSURE	HEAD LINING — FLAT STEEL CEILING
" " POSTS — 73'2"	WHEELS — ROLLED STEEL 36" D.	VAPOR HEAT — FINN RADIATION	LIGHTING — AXEL GEN. — ELEC. —
WIDTH " ANGLES — 10'0"	KIND OF TRUCK — CAST STEEL	AIR COND. — ICE ACTIVATED	DRAFT GEAR — MINOR FRICTION
" " CROWN MLDG. 10'2 3/8"	JOURNALS — — 5"x9"	" " DUCT — SINGLE CENTER	COUPLER — 5"x7" "E" SWIV. BUTT.
SEATING CAPACITY — 52			

BUILT BY B.O.S CAR CO 1914  
AIR COND. NEW TRUCKS REMODELED 1939

# FIRST CLASS STEEL COACH No. 977

AIR CONDITIONED

95

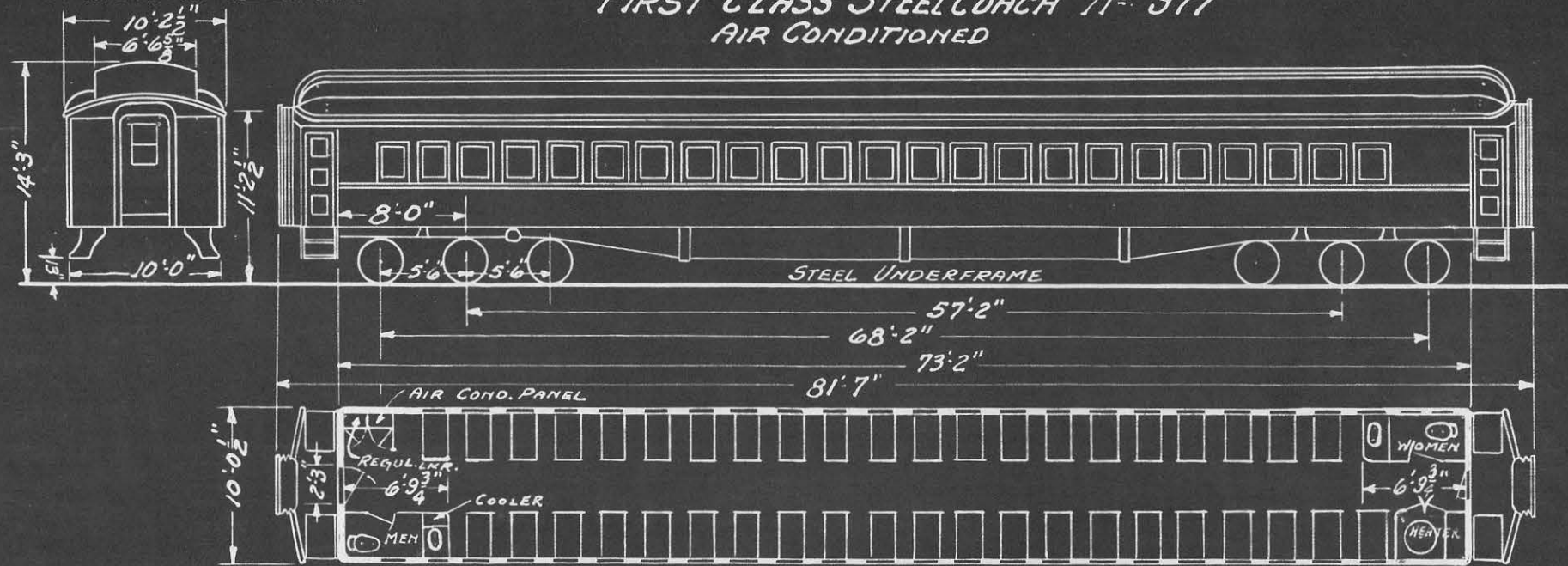

4-24-40 REV. 5-2-41 5-26-43

A.F.E 5311

PB

WEIGHT (LIGHT) —————	176,200 LBS.	TRUCK CENTERS —————	57'-2"	AIR BRAKES —————	4-10x8" CYL. TR. MT'D.	OUTER FINISH —————	STEEL
" LOADED (BATT & ICE) ———	185,200 LBS.	" WHEEL BASE —————	11'-0"	HEATER —————	GOLD'S DOUBLE COIL 1/4" PIPE	INSIDE " —————	"
LENGTH OVER BUFFERS ———	81'-7"	TOTAL " —————	68'-2"	WATER SYSTEM —————	PRESSURE	HEAD LINING ———	FLAT STEEL CEILING
" " POSTS —————	73'-2"	WHEELS —————	ROLLED STEEL 36" DIA.	AIR COND. —————	ICE ACTIVATED	LIGHTING —————	ELECTRIC
WIDTH " ANGLES —————	10'-0"	KIND OF TRUCK —————	CAST STEEL	" " DUCT —————	SINGLE CENTER	DRAFT GEAR ———	MINER
" " CROWN MLD'G. ———	10'-2 1/2"	JOURNALS —————	5"x9"	VAPOR HEAT —————	FIN RADIATION	COUPLER —————	5x7 "E" SWIVEL BUTT.
SEATING CAPACITY —————	84			CLASP BRAKE —————	SIMPLEX		

BUILT BY B & S CAR CO. 1914  
 AIR COND. NEW TRUCKS, REMODELED 1940

# SMOKER & FIRST CLASS STEEL COACH 978 & 979

AIR CONDITIONED.

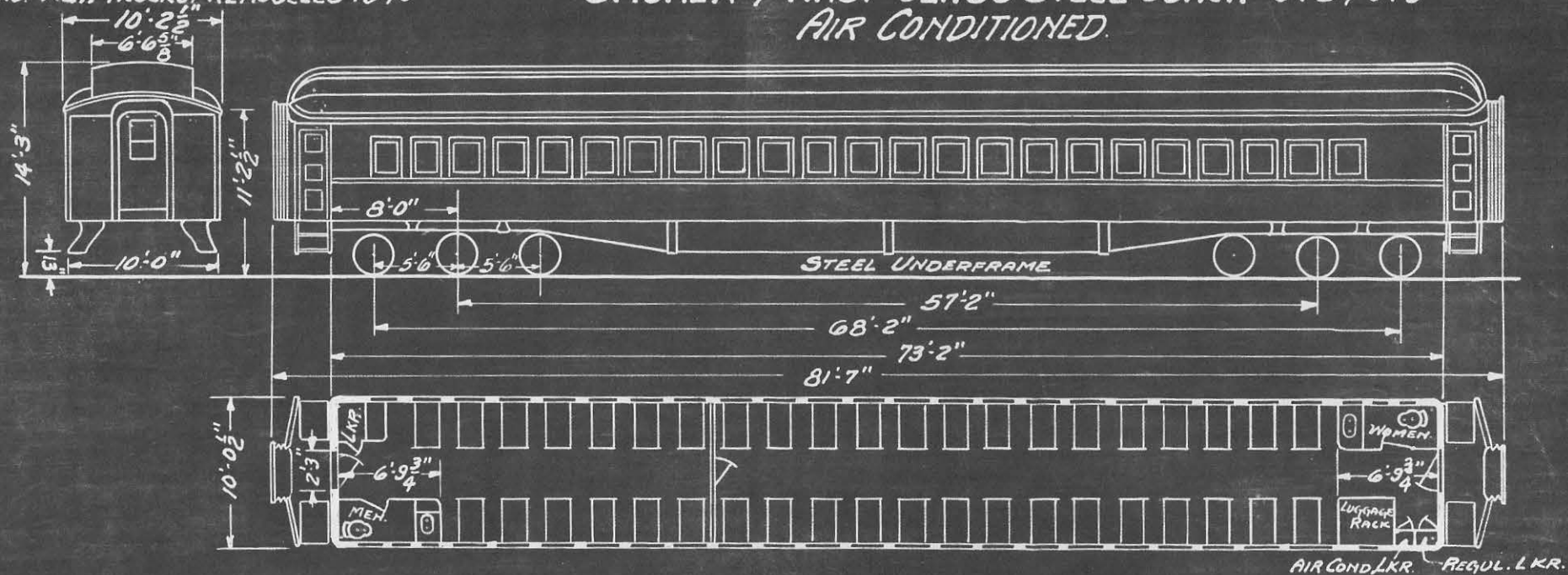

PB

WEIGHT LIGHT	173800 #	TRUCK CENTERS	57'-2"	AIR BRAKES	4-10" x 8" Cyl. Tr. Mtd.	OUTSIDE FINISH	STEEL
" LOADED (BATT. & ICE)	184000	" WHEEL BASE	11'-0"	" WATER SYSTEM	PRESSURE	INSIDE "	"
LENGTH OVER BUFFERS	81'-7"	TOTAL "	68'-2"	" AIR COND.	ICE ACTIVATED	HEADLINING	FLAT STEEL CEILING
" " POSTS	73'-2"	WHEELS	ROLLED STEEL 36" DIA.	" " DUCT	SINGLE (CENTER)	LIGHTING	ELECTRIC
WIDTH " ANGLES	10'-0"	KIND OF TRUCK	CAST STEEL	VAPOR HEAT	FINN. RADIATION	DRAFT GEAR	(A-5-XB) MINER
" " CROWN MLDG.	10'-2 1/2"	JOURNALS	5" x 9"	GLASP BRAKES	SIMPLEX	COUPLER	5" x 7" "E" SWIVEL BUTT.
SEATING CAPACITY	83						

center duct

4-24-40 12-15-41 11-12-42 5-26-43



BUILT BY PULLMAN.  
PURCH. FROM PULLMAN 1938.

# FIRST CLASS COACHES 990 TO 995.

97

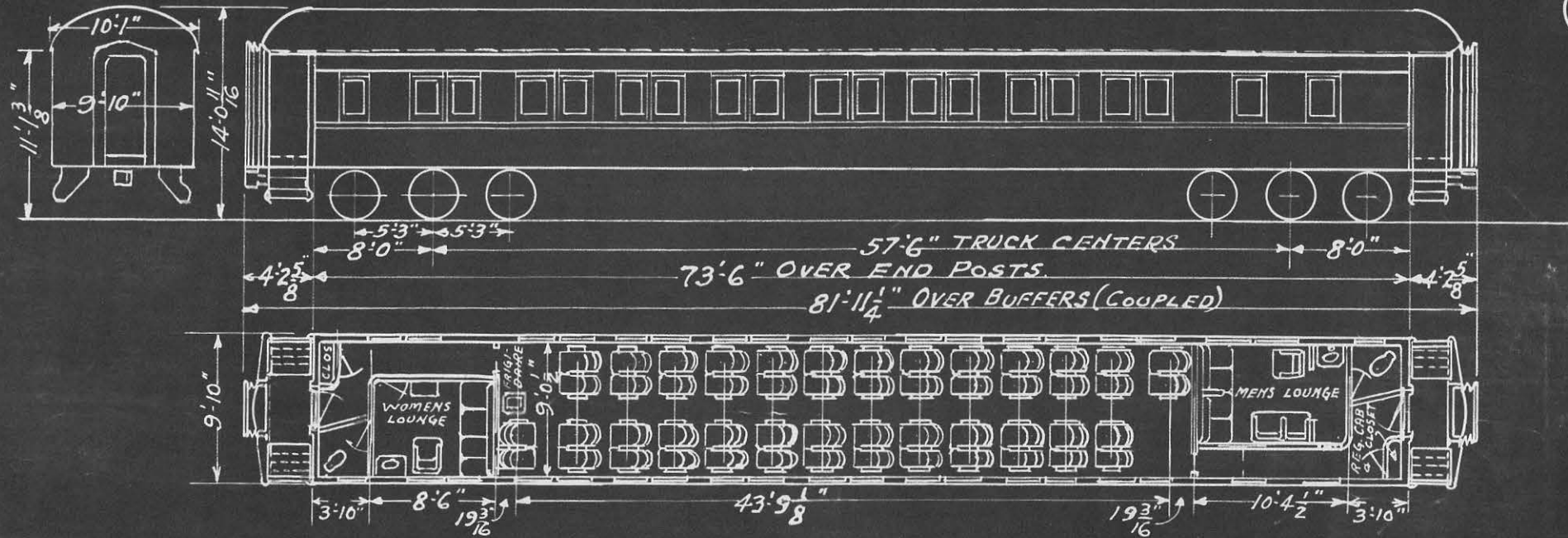

AFE 54624.

PBA

WEIGHT	170600 LBS.
LENGTH OVER FRAMING	73'-6"
" " BUFFERS	81'-11 1/4"
WIDTH OVER FRAMING	9'-8 1/2"
" " EAVES	10'-1"
INSIDE LENGTH	72'-10"
" " WIDTH	9'-0 1/2"

TRUCK CENTERS	57'-6"
" WHEEL BASE	10'-6"
TOTAL " "	68'-0"
KIND OF TRUCK	CAST STEEL PULL 240A
WHEELS	ROLLED STEEL - 36 1/2 DIA.
JOURNALS	5" x 9"
SEATING CAPY	52

AIR BRAKES	1-18" CYL - UCB4 UCBC
WATER SYSTEM	PRESSURE
AIR CONDITIONED	ICE
AIR DUCTS	SIDE DECK
HEATING	FIN RAD. - VAPOR
CLASP BRAKE	SIMPLEX

OUTSIDE FINISH	STEEL.
INSIDE " "	" "
HEADLINING	FLAT STEEL CEILING.
LIGHTING	AXLE GEN - ELECTRIC
DRAFT GEAR	WESTINGHOUSE N-10-F
COUPLER	TYPE "D"

8-20-35 4-24-40 5-26-43

BUILT BY PACIFIC RY. EQUIP. CO. -1942

# FIRST CLASS COACH No 999

98

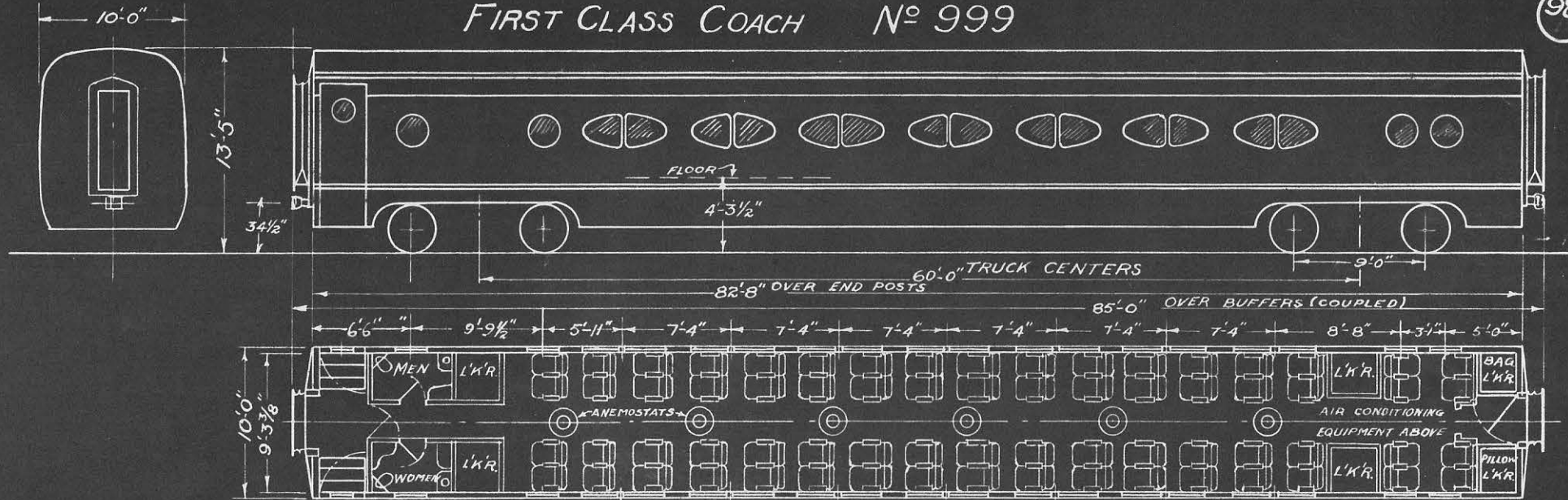

A.F.E. 57213

PB

3-19-42 5-26-43

WEIGHT	106,920 LBS	TRUCK CENTERS	60'-0"	AIR BRAKE	4-10"x8" CYLS. TRUCK MTD.	WATER SYSTEM	PRESSURE
LENGTH OVER FRAMING	82'-8"	TRUCK WHEELBASE	9'-0"	TRUCK	BUILT UP (CROMANSIL) WELDED	FINISH - EXTERIOR	STAINLESS STEEL
" " BUFFERS	85'-0"	TOTAL	69'-0"	VAPOR HEAT	THERMOS. CONTROL	" - INTERIOR	PLYWOOD
WIDTH - INSIDE	9'-3 3/8"	WHEELS - ROLLED STEEL	36"	COUPLER	AAR TIGHT-LOCK	HEADLINING	ALUMINUM ALLOY
" - OUTSIDE	10'-0"	JOURNALS	5 1/2"x10"	CLASP BRAKES	SIMPLEX	GENERATOR	AXLE 20KW-VBELT DRIVE
TOTAL HEIGHT (FROM TOP OF RAIL)	13'-5"	ROLLER BEARING	TIMKEN	AIR CONDITIONING	MECHAN. (FRIGIDAIRE)	LIGHTING	FLOURESCENT & INCANDESC.
SEATING CAPACITY	68	BUFFER	MINER - B-18-X	" " DUCT	CENTER	DRAFT GEAR	MINER - CL. A-4XB

BUILT BY A.C.&F. CO. 1913.  
STEEL SHEATHING APPLIED 1925

# SLEEPER, SMOKER, COACH Nos 1000, 1001.

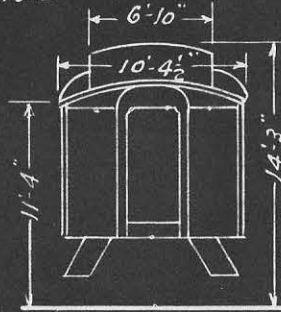

CHANGED TO SLEEPER, SMOKER, COACH - 1933.  
FORMERLY CAR Nos 662, 663.

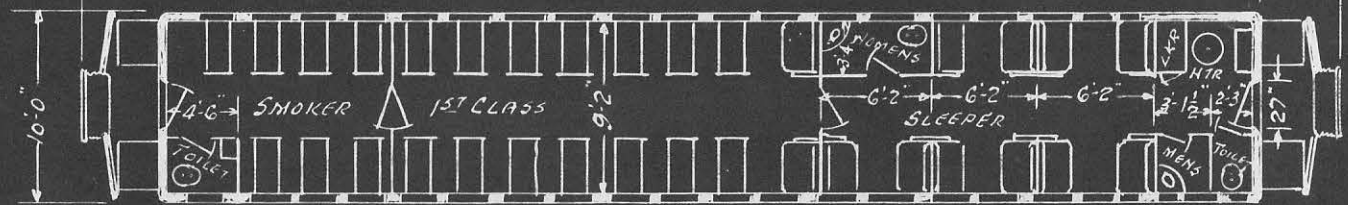
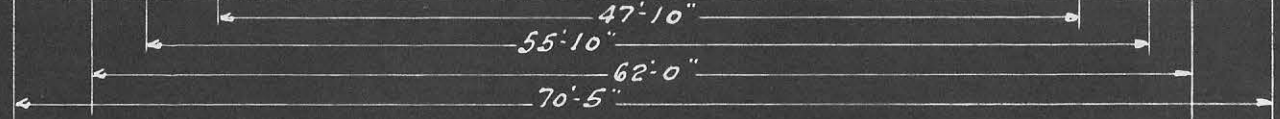
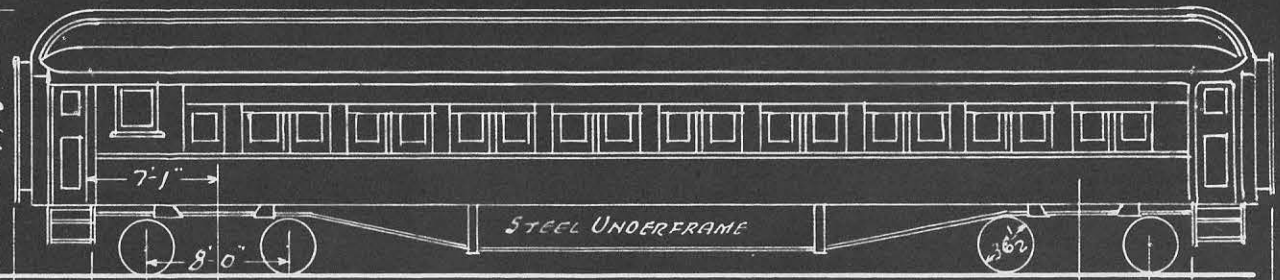

A.F.E. 28202, 29880, 32959, 47369.

PB

9-20-33. 5-26-43

WEIGHT	125000 LBS	TRUCK CENTERS	47'-10"	AIR BRAKE	18" x 12" CYL.	FINISH, EXTERIOR	STEEL SHEATHING
LENGTH OVER FRAMING	62'-0"	WHEEL BASE - TRUCKS	8'-0"	HEATER	GOLD DUPLEX A.C.&F. CO.	" INTERIOR	BIRCH MAH'Y 5TH.
" " BUFFERS	70'-5"	" " - TOTAL	55'-10"	WATER SYSTEM	PRESSURE	HEAD LINING	3 PLY POPLAR VENEER
WIDTH " FRAMING	10'-0"	WHEELS - ROLLED STEEL	36 1/2" DIA.			LIGHTING	ELECTRIC
" " CROWN MLDG.	10'-4 1/2"	JOURNALS - SIZE	5" x 9"			LAMPS	BERRY LITE
SEATING CAPACITY	66	KIND OF TRUCK	METAL FACED			DRAFT GEAR	MINER FRICTION A-5-X
						COUPLER	SHORT SHANK 9 3/8" BUTT.
						BUFFER	MINER FRICTION B-10-X.



BUILT BY A.C.&F. Co. 1913  
 STEEL SHEATH'G. APPLIED 1924, 1927.

# SLEEPER, SMOKER, COACH Nos 1002 TO 1004.

100

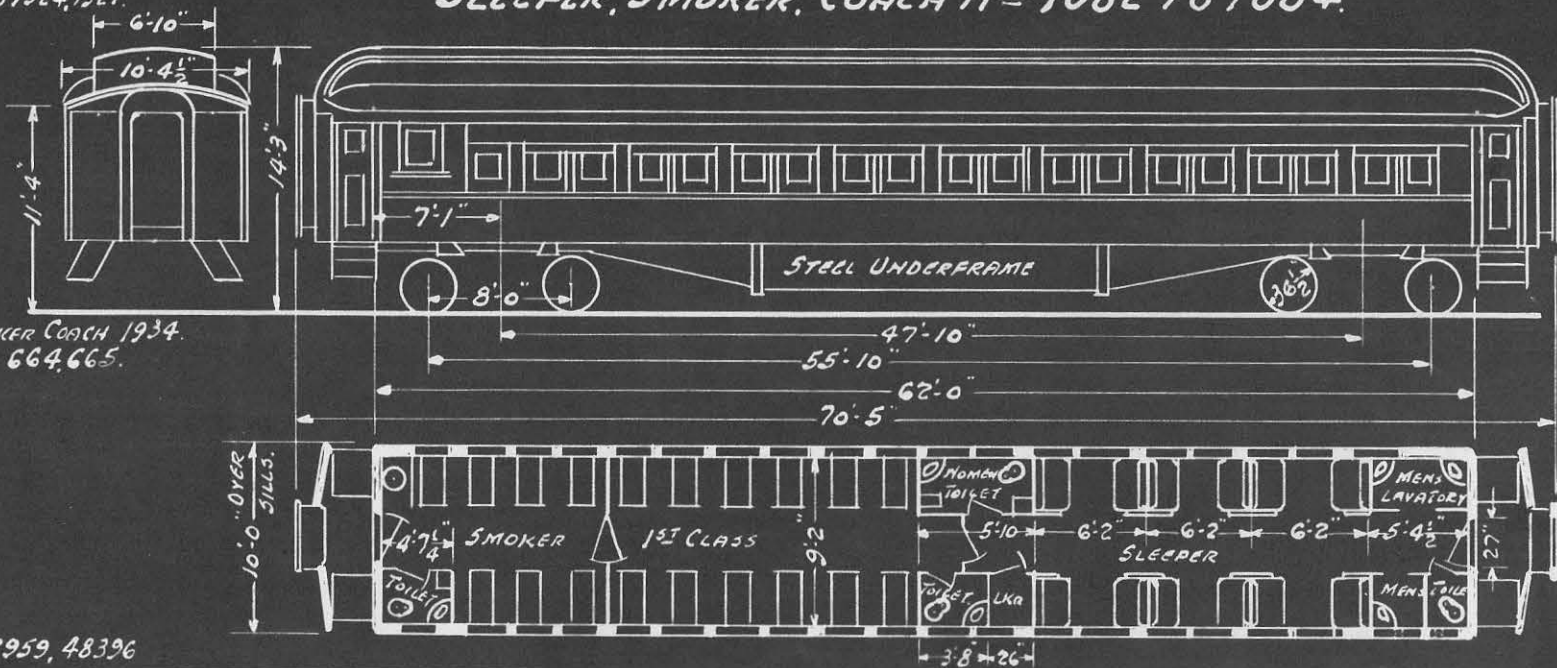

CHANGED TO SLEEPER, SMOKER COACH 1934.  
 FORMERLY CAR Nos 661, 664, 665.

A.F.E 28202 25986, 32959, 48396

10.15.34. 5-26-43

WEIGHT	123000 LBS.	TRUCK CENTERS	47'-10"	AIR BRAKE	18" x 12" CYL.	FINISH EXTERIOR	STEEL SHEATH'G.
LENGTH OVER FRAMING	62'-0"	WHEEL BASE - TRUCKS	8'-0"	HEATER	GOLD DUPLEX A.C.&F. Co.	INTERIOR	BIRCH, MAH'Y 5 1/4"
" " BUFFERS	70'-5"	" - TOTAL	55'-10"	WATER SYSTEM	PRESSURE.	HEAD LINING	3 PLY POPLAR VENEER.
WIDTH " FRAMING	10'-0"	WHEELS - ROLLED STEEL	36 1/2" DIA.	* CAR No 1002 EQUIPPED WITH MINER		LIGHTING	AXLE GEN. - ELECTRIC.
" " CROWN MLDG.	10'-4 1/2"	JOURNALS - SIZE	5" x 9"	FRICTION DRAFT GEAR	A-5-X. AND	LAMPS	BERRY LITE.
SEATING CAPACITY	62.	KIND OF TRUCK	METAL FACED.	MINER FRICTION BUFFER	B-10-X.	DRAFT GEAR	* FARLOW 6" x 8" SPRING.
						COUPLER	LONG SHANK 6 1/2" BUTT.

BUILT BY PULLMAN 1030 TO 1037, 1929

1038, 1039, 1925  
1040, 1041, 1926

# DINING CAR NOS 1030 TO 1049, 1050, 1051

101

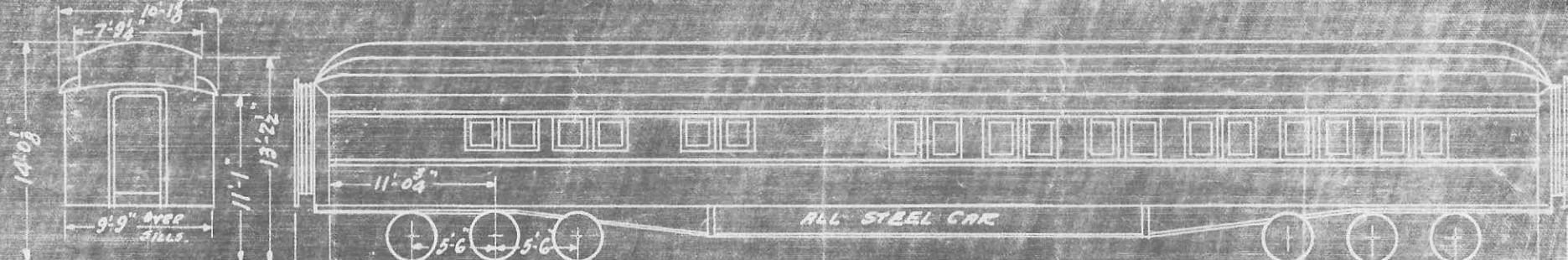

BUILT BY PULLMAN 1042 TO 1047, 1929

1048, 1049, 1929

1050, 1051, 1930

AIR CONDITIONING APPLIED-1934-PULL. C. M. CO.

AIR CONDITIONING APPLIED

X WEST GEAR ON

1031, 1032, 1033, 1035, 1037,  
1040, 1043, 1046, 1047,  
1049 TO 51.

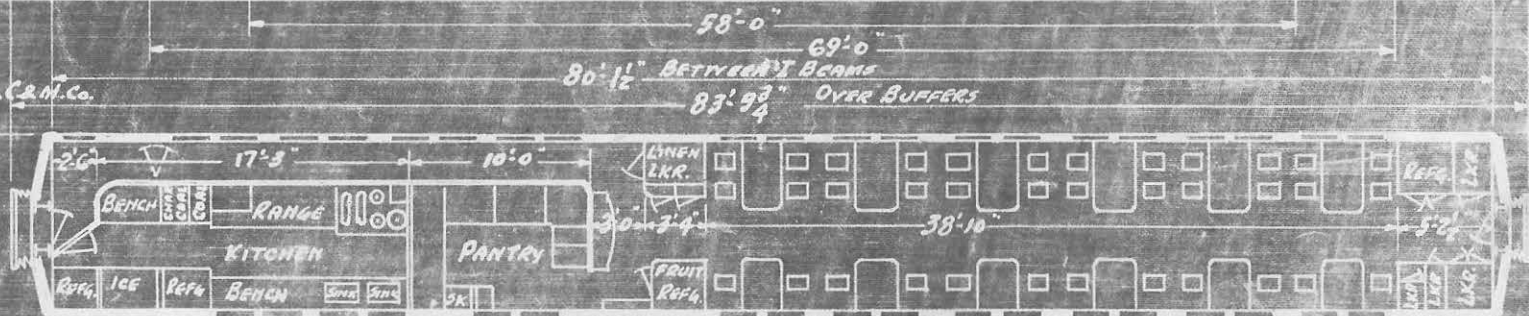

A.F.F. 25219, 27130, 30174, 37735, 40211, 40782, 50490, 57557

WEIGHT	199 700 LBS.	TRUCK CENTERS	58'0"	AIR BRAKE	TWO-UG-1612	NEW YORK	FINISH EXTERIOR	SHEET STEEL
LENGTH BETWEEN I BEAMS	80'1 1/2"	WHEEL BASE TRUCK	11'0"	AIR SIGNAL	"	"	" INTERIOR	"
" OVER BUFFERS	83'9 3/4"	" TOTAL	69'0"	HEATING	VAPOR.	"	HEAD LINING	"
WIDTH " FRAMING	9'9"	WHEELS	ROLLED STEEL 36" DIA.	CLASH BRAKE	SIMPLEX	"	LIGHTING	AXLE GEN. ELECTRIC
" " CROWN MLOG.	10'1 1/8"	JOURNALS	SIZE 5 1/2" x 10"	FRIGIDAIRE-ICE CREAM CABINET-CAR NOS	1042 TO 1051, 1030 TO 1041.	"	DRAFT GEAR	X MINER A-5 P.Y.
SEATING CAPACITY	36.	KIND OF TRUCK	PULLMAN TYPE	AXLE GEN FOR V BELT DRIVE	"	"	BUFFING DEVICE	MINER B-10.
		AIR CONDITIONED CAR NOS	1030 TO 51.					

5-26-30  
 Rev. 6-1-29, Rev. 1-3-30, Rev. 1-29-30, Rev. 6-1-30, Rev. 1-2-35, Rev. 5-1936, 12-15-41  
 7-1-24, Rev. 2-26-25, Rev. 6-1-25, Rev. 3-1-26, Rev. 7-16-26, Rev. 4-1-28, Rev. 11-28-28

BUILT BY B.S. 1911 REMODELED G.N.R. 1922.  
 STEEL UNDERFRAMED SHEATHED & VESTIBULE APPLIED, 1930.  
 AIR CONDITIONED, 18, NEW TRUCKS 1937.

# CAFE-OBSERVATION CAR Nos. 1057 & 1058.

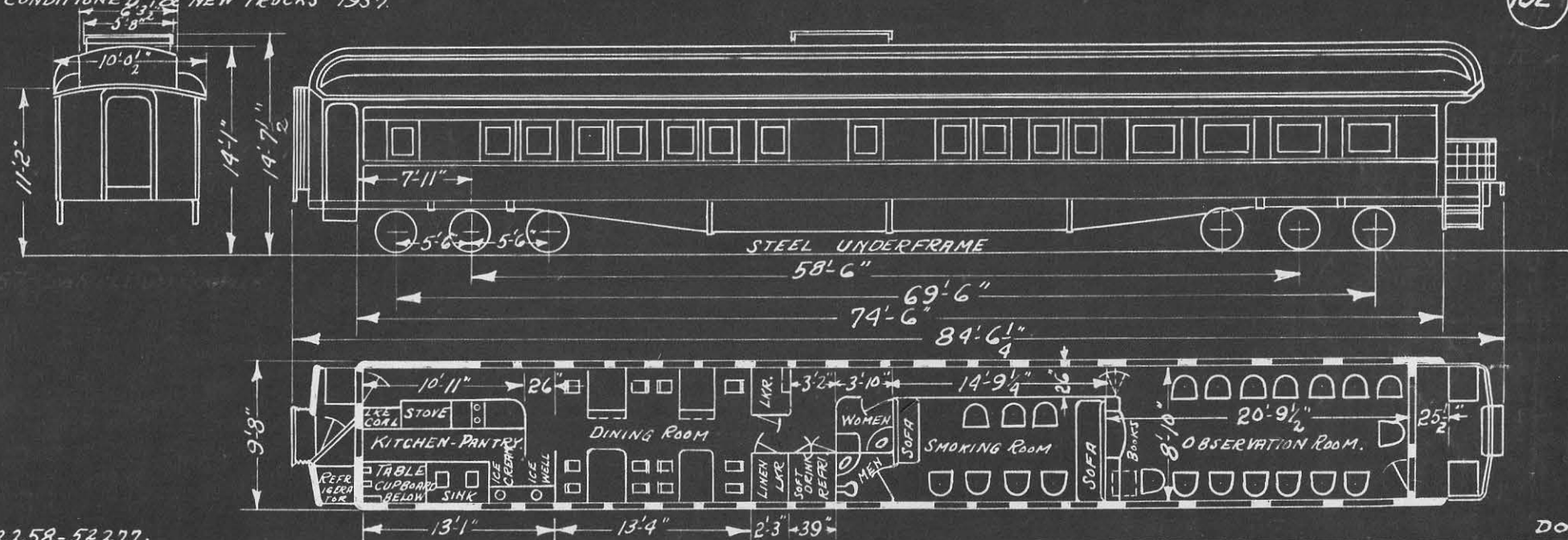

OCT 1, 1937. REV. 5-2-41 5-26-43

A.F.E. 42258-52277.

1057 WEIGHT	Lbs. 185,300
1058 " "	" "
1057 " LOADED ICE & BAT.	192,000
1058 " " " " "	" "
LENGTH OVER FRAMING	74'-6"
LENGTH OVER BUFFERS	84'-6 1/4"
WIDTH OVER FRAMING	9'-8"
WIDTH OVER CROWN MLDG.	10'-0 1/2"

TRUCK CENTERS	58'-6"
WHEEL BASE TRUCK	11'-0"
" " TOTAL	69'-6"
" ROLLED STEEL	36" DIA.
JOURNAL SIZE	5" x 9"
KIND OF TRUCK	CAST STEEL

AIR BRAKES	18" x 12" CYL.
AIR SIGNALS & VAPOR HEAT	" "
RADIATION	FINN TYPE
WATER SYSTEM	PRESSURE
CLASP BRAKE	SIMPLEX.
AIR COND.	ICE ACTIVATED.
" " DUCT	OUTSIDE SINGLE.

FINISH EXTERIOR	STEEL SHEATHING
" INTERIOR	VARIOUS WOODS.
HEAD LINING	3-PLY VENEER PAINTED
LIGHTING	AXEL GEN. - ELECT.
DRAFT GEAR	A-5 x B. - MINER
COUPLER	5" x 7" "E" SWIV. BUTT
SEATING CAP.	27.



BUILT BY B. & S. 1911.  
 STEEL UNDERFRAME, SHEATHING & VESTIBULE APPLIED 1923.  
 REBUILT 1924. AIR CONDITIONED & NEW TRUCKS 1937.

# CAFE-OBSERVATION Nos. 1062.

103.

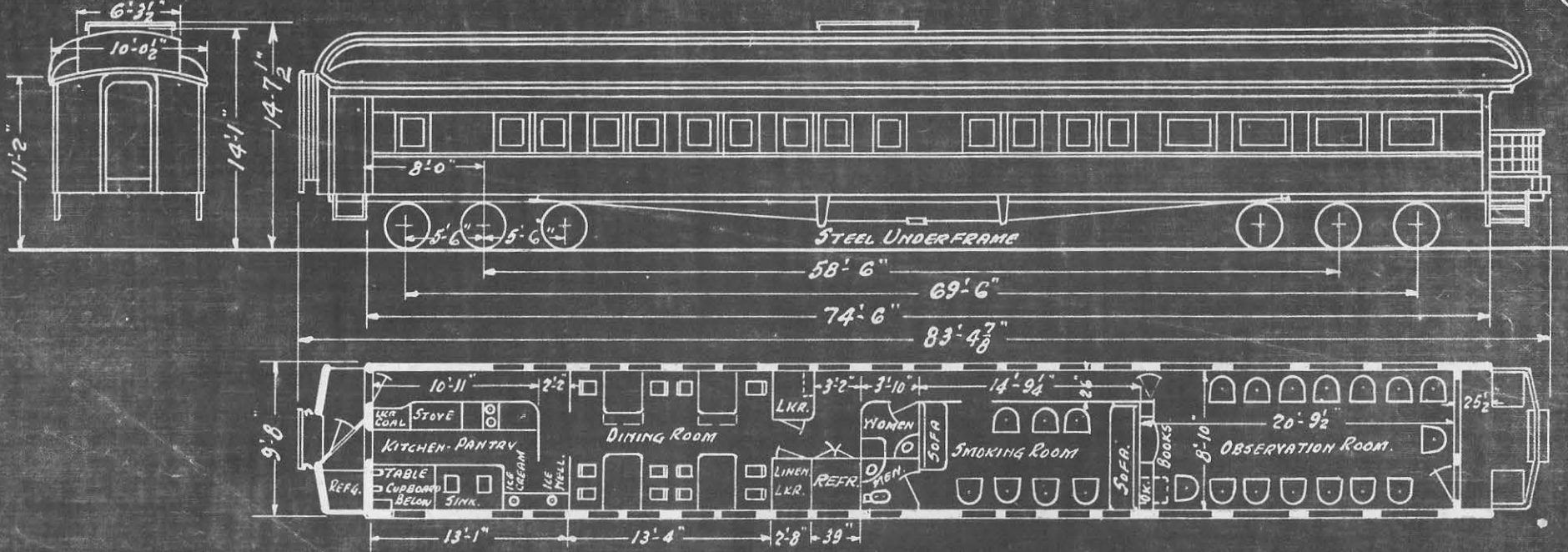

A.F.E 20785 & 25985. 52277.

DD

WEIGHT - LIGHT	TRUCK CENTERS	58'-6"	AIR BRAKE - 2-16"x12" CYL. - NEW YORK.	FINISH-EXTERIOR	SHEET STEEL.
LENGTH OVER FRAMING	WHEELBASE-TRUCK	11'-0"	SIGNAL	" INTERIOR	VARIOUS WOODS.
" " BUFFERS	" " - TOTAL	69'-6"	AIR COND. - ICE ACTIVATED	HEAD LINING	3 PLY VENER PRINTD
WIDTH " FRAMING	WHEELS ROLLED STEEL	36" DIA.	VAPOR HEAT	LIGHTING	AXLE GEN. ELECTRIC.
" " CROWN MLDG.	JOURNALS-SIZE	5"x9"	COUPLER - SHORT SHANK	DRAFT GEAR	MINER
SEATING CAPACITY	KIND OF TRUCK	CAST STEEL	CLASP BRAKE	BATT. 2000"	ICE

5-1-24. Rev. 12-15-24. Rev. 3-1-26. Rev. 1-29-30. Rev. 6-1-30. 5-26-43

BUILT BY B. & S. 1911

STEEL UNDERFRAME, SHEATHING & VEST. APPLIED 1923.

CHANGED FROM COMPT. OBS. CAR 1933, 1934. AIR

# CAFE-OBSERVATION CAR Nos 1063, 1064.

104

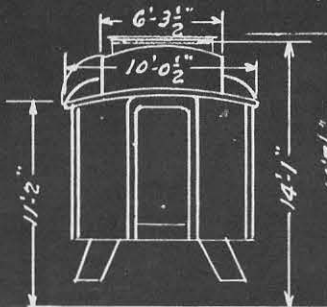

FORMERLY CAR Nos 1110, 1113.

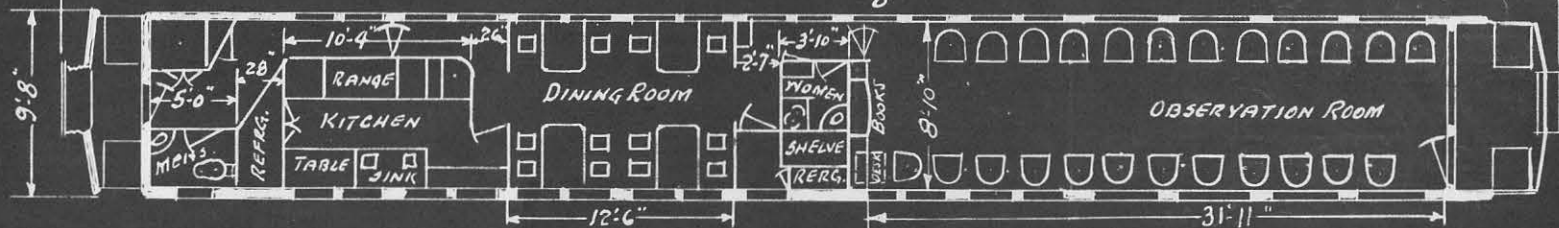
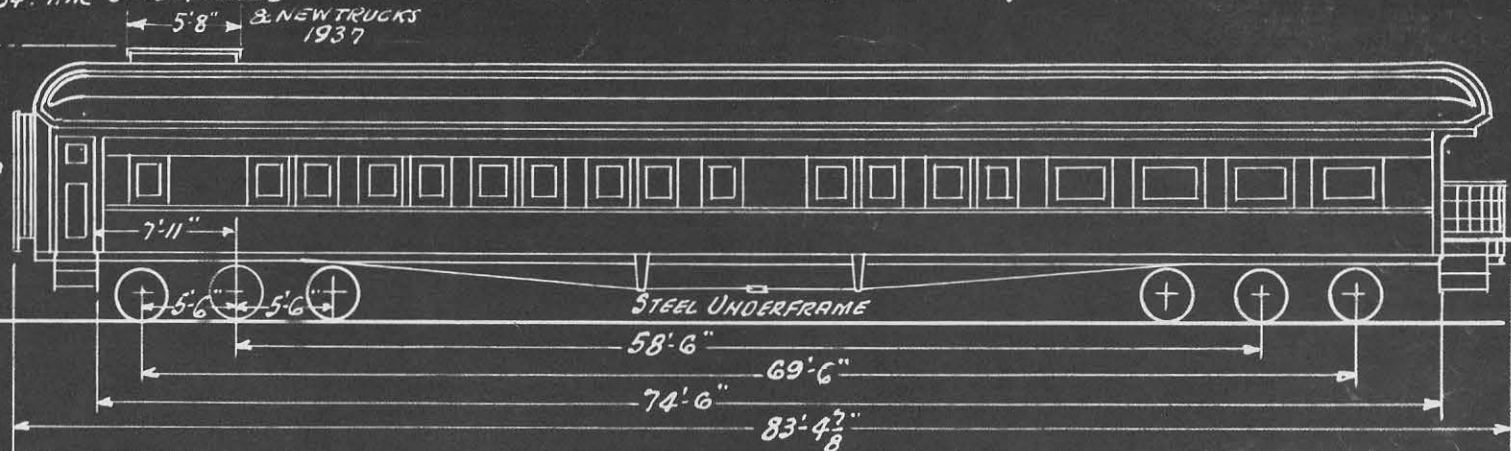

A.F.E. 20785, 47453, 52277.

WEIGHT LIGHT	175,300 LBS.
LENGTH OVER FRAMING	74'-6"
" " BUFFERS	83'-4 7/8"
WIDTH " FRAMING	9'-8"
" " CROWN MLDG.	10'-0 1/2"
BATT. 2000 #	ICE 3760 #
SEATING CAPACITY	24

TRUCK CENTERS	58'-6"
WHEEL BASE-TRUCK	11'-0"
" " TOTAL	69'-6"
WHEELS - ROLLED STEEL	36" DIA.
KIND OF TRUCK	CAST STEEL
JOURNALS - SIZE	5 x 9"

AIR BRAKE	2-16x12" CYL.
AIR SIGNAL	
AIR COND.	ICE ACTIVATED
" " DUCT	OUTSIDE SINGLE
CLASP BRAKE	SIMPLEX
WATER SYSTEM	PRESSURE
VAPOR HEAT	

FINISH - EXTERIOR	STEEL SHEATH'G.
" - INTERIOR	VARIOUS WOODS
HEAD LINING	3 PLY VENEER PAINTED
LIGHTING	AXLE GEN. ELECTRIC.
DRAFT GEAR	MINER A-5-P.
COUPLER	5x7 "E" SWIVEL BUTT.

12.21.33. REV. 8.13.35. REV. 9-28-37. REV. 5-2-41. 5-26-43

BUILT BY PULLMAN - 1929.  
PURCH. G. N. - 1941.

# COACHES 1070, 1076.

105

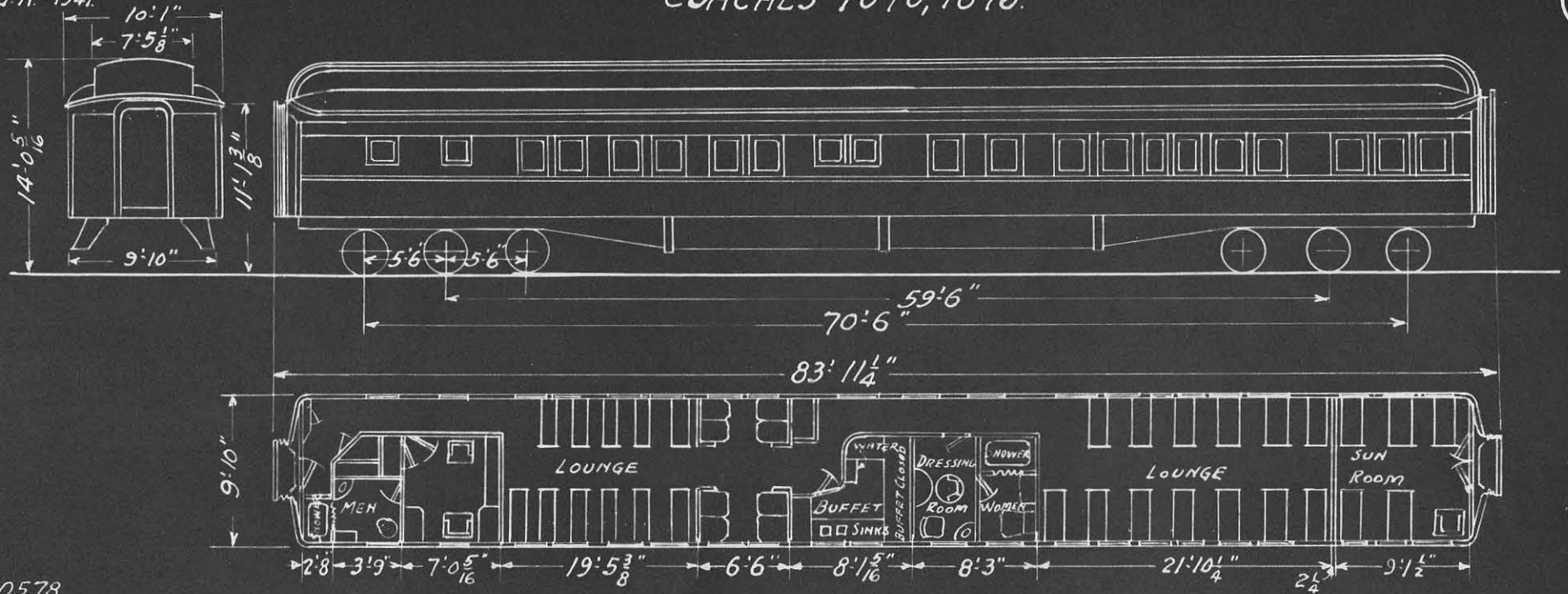

5-26-93 6-7-43

AFE 60578

PB

WEIGHT	184000 LBS.	TRUCK CENTERS	59' 6"	AIR BRAKES	N.Y. 2-16" x 12" CYLS.	OUTSIDE FINISH	STEEL
LENGTH OVER COUPLER FACES	83' 11 1/4"	" WHEEL BASE	11' 0"	CLASP BRAKES	SIMPLEX.	INSIDE "	NAT. WALNUT.
WIDTH " CROWN MLDG	10' 1"	TOTAL "	70' 6"	WATER SYSTEM	PRESSURE.	LIGHTING	AXLE GEN. ELECTRIC.
" " FRAMING	9' 10"	WHEELS	ROLLED STEEL 36 1/2"	HEATING	VAPOR CAR HTG. Co.	DRAFT GEAR	WESTINGHOUSE
SEATING CAPACITY	59	KIND OF TRUCK	CAST STEEL	AIR CONDITIONING	ICE	COUPLERS	A.S.F. TYPE "D".
WIDTH INSIDE	9' 0 1/2"	JOURNALS	5" x 9"				



BUILT BY PULLMAN-1929  
PURCH. G.N.-1941

OBSERVATION-LOUNGE CAR Nos. 1071 to 1075.

106

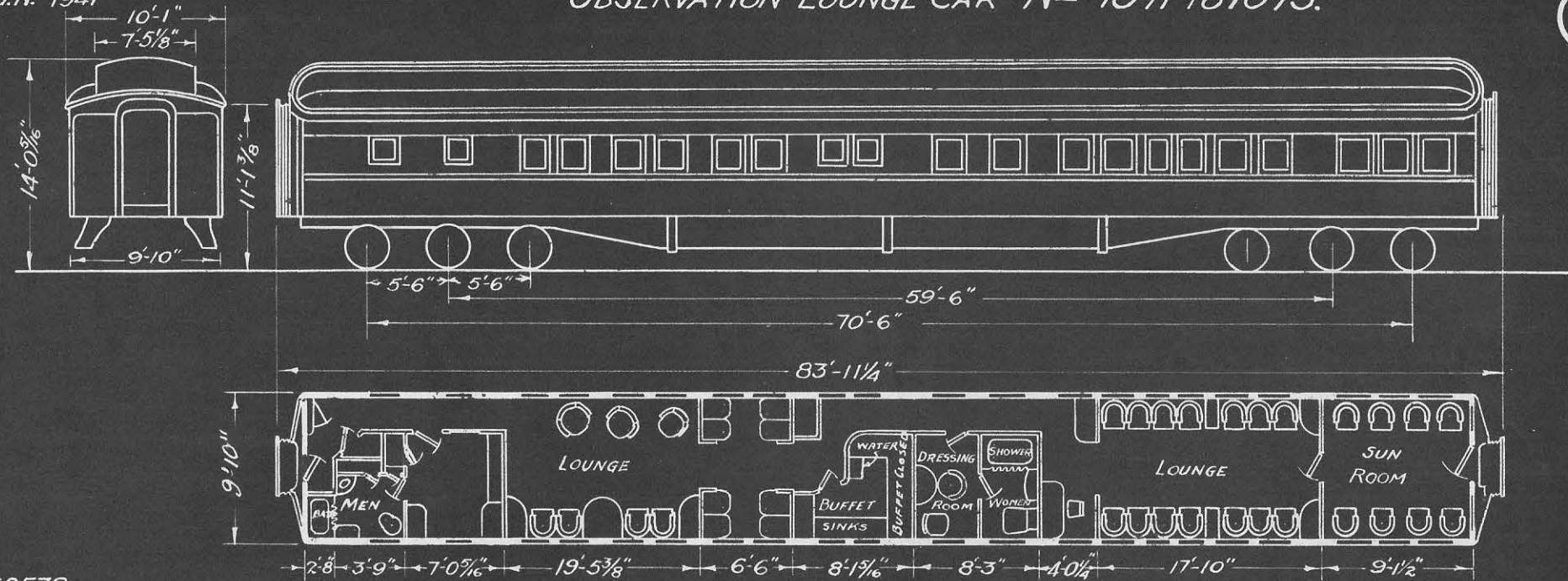

A.F.E. 60578.

PC

WEIGHT	177900 LBS.	TRUCK CENTERS	59'-6"	AIR BRAKES	N.Y. 2-16" x 12" CYLS.	OUTSIDE FINISH	STEEL
LENGTH OVER COUPLER FACES	83'-11 1/4"	" WHEELBASE	11'-0"	CLASP BRAKES	SIMPLEX	INSIDE FINISH	NAT. WALNUT
WIDTH OVER CROWN MOLDING	10'-1"	TOTAL	70'-6"	WATER SYSTEM	PRESSURE	LIGHTING	AXLE GEN. - ELECTRIC
" " ANGLES	9'-10"	WHEELS	ROLLED STEEL 36 1/2"	HEATING	VAPOR CAR H.T.G. CO.	DRAFT GEAR	WESTINGHOUSE
SEATING CAPACITY	37	KIND OF TRUCK	CAST STEEL	AIR CONDITIONING	ICE	COUPLERS	A.S.F. TYPE "D"
WIDTH - INSIDE	9'-0 1/2"	JOURNALS	5" x 9"				

5-26-43 6-7-43

BUILT BY PULLMAN CO. 1920.

# COACHES Nos 1083, 1084

167

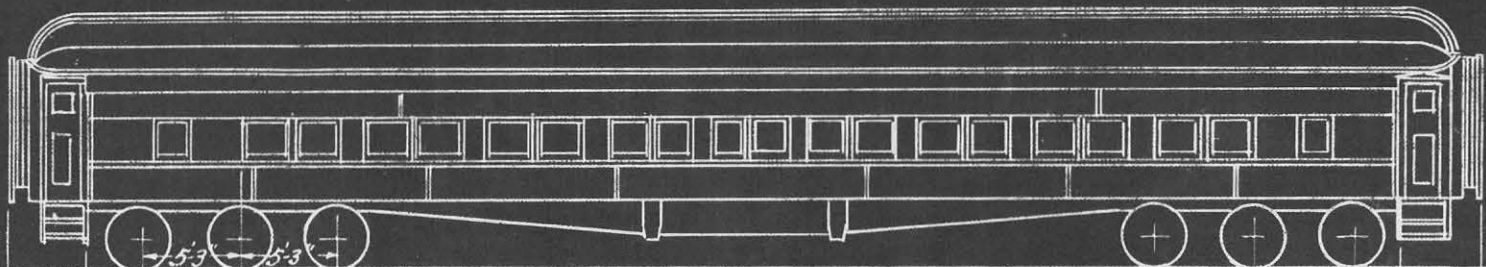
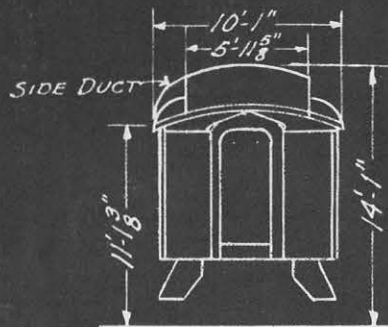

LEASED FROM PULLMAN CO.  
PURCH. " " " 1942

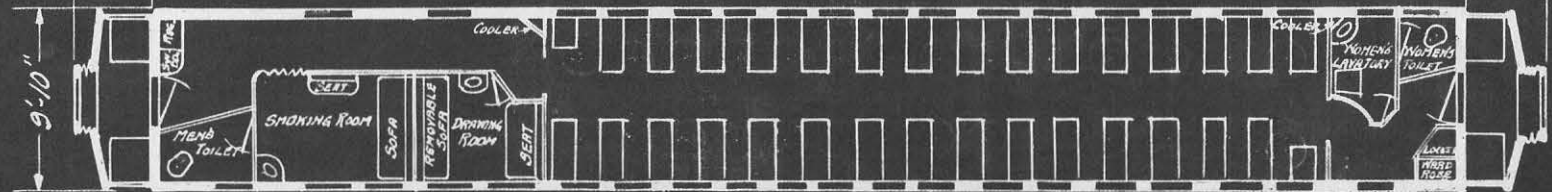
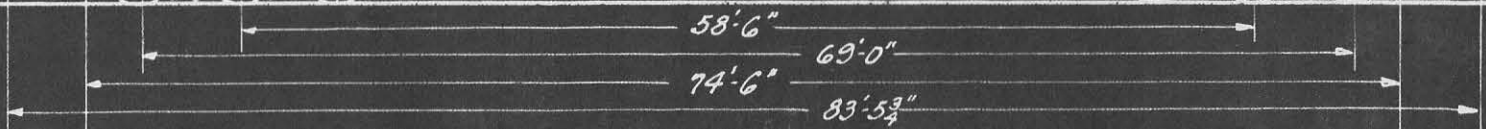

6-4-40, 5-26-43 7-31-44.

AFE 64359.

6 TON PULLMAN MECH. AIR COND. - NO HOLDOVER TANK.

PB

WEIGHT -----	163 800 LB.	TRUCK CENTERS -----	58'-6"	AIR BRAKE -----	1-18X12 WAB	FINISH-EXTERIOR -----	METAL PAINTED
LENGTH OVER FRAMING -----	74'-6"	WHEEL-BASE-TRUCKS -----	10'-6"	" SIGNAL -----	WAB	" - INTERIOR -----	STEEL
" " BUFFERS -----	83'-5 3/4"	" " - TOTAL -----	69'-0"	HEATING -----	AUTO-VAPOR	HEAD LINING -----	METAL
WIDTH " FRAMING -----	9'-8"	WHEELS-ROLLED STEEL -----	36 1/2"	WATER SYSTEM -----	PRESSURE	LIGHTING -----	ELEC-GENERATOR.
" " CROWN MLDG. -----	10'-1"	JOURNAL SIZE -----	5" x 9"	CHAIRS -----	27-MOHAIR PLUSH	COUPLER	
SEATING CAPACITY -----	62	KIND OF TRUCK -----	PULLMAN TYPE	SEATS- 4 LEATHER- 6 CLOTH FABRIC		DRAFT GEAR	

BUILT BY B & S Co. 1909.

STEEL UNDERFRAME & SHEATHING APPLIED 1924 1926

AIR CONDITIONED & REMODELED 1937.

COACHES 1085 & 1086.

108

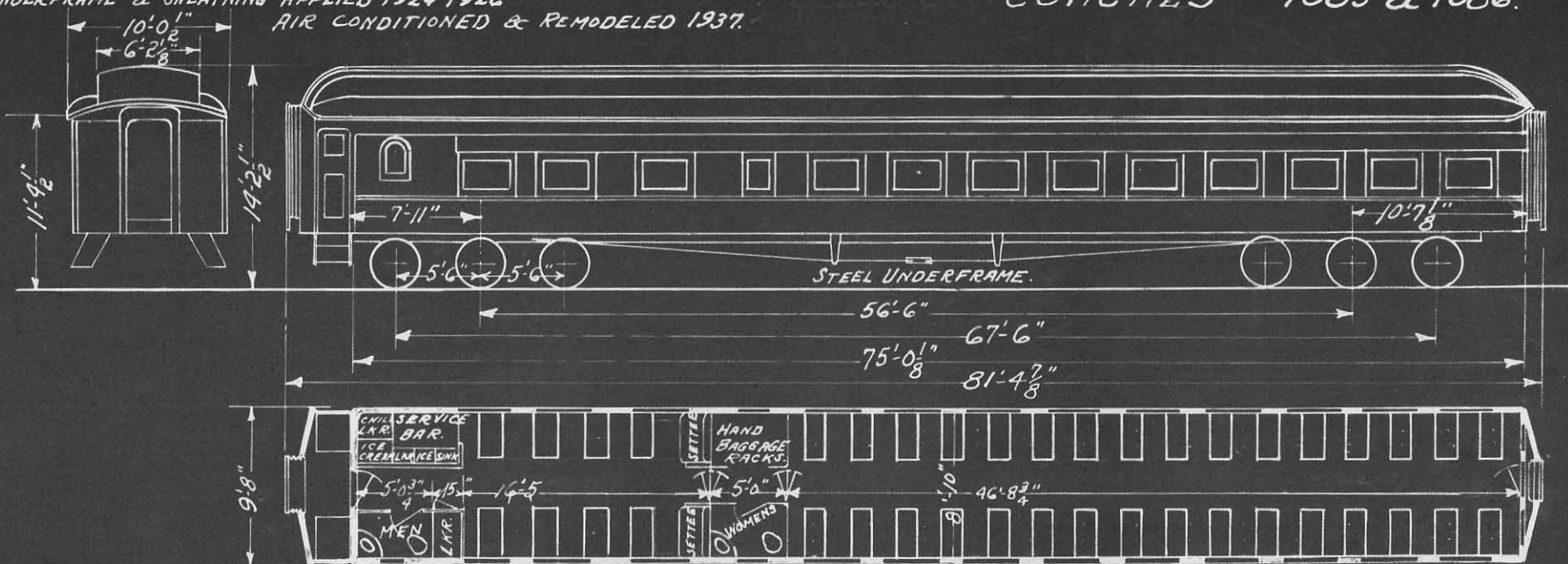

A.F.E. 25066, 27635, 52277.

PB

WEIGHT - 1085 - LIGHT	172,800	TRUCK CENTERS	56'-6"	AIR BRAKE	2-16"x12" CYL NEW-Y.	FINISH EXTERIOR	SHEET STEEL
" - 1086 - "	171,800	WHEEL BASE - TRUCK	11'-0"	AIR SIGNAL	" "	" INTERIOR	WOOD PAINTED
" 1085 LOADED ICE & BATT.		" " TOTAL	67'-6"	AIR COND.	ICE ACTIVATED	HEAD LINING	STEEL CEILING.
" 1086 " " " "		WHEELS - ROLLED STEEL	36 1/2" DIA.	AIR DUCT	CENTER DUCT	LIGHTING	AXLE GEN. - ELECTRIC
LENGTH OVER FRAMING	75'-0 1/8"	KIND OF TRUCK	CAST STEEL.	WATER SYSTEM	PRESSURE	DRAFT GEAR	MINER
" " BUFFERS	81'-9 7/8"	JOURNALS - SIZE	5"x9"	COUPLER	SHORT SHANK - 9 1/8" BUTT.	CHAIRS - OBS. RM.	(WICKER REVOLVING)
WIDTH " FRAMING	9'-8"	BUFFERS OBS. END	FOWLER IMP. TYPE	HEAT	VAPOR	SEATING	" " - 84 Pass.
" " CROWN MLDG.	10'-0 1/2"	HAND BRAKE OBS. END	MINER	RADIATION	FINN TYPE		

AUG. 27, 1937. 5-26-43



BUILT BY B. & S 1910  
 STEEL UNDERFRAME, SHEATHING & VESTIBULE APPLIED 1925.

# SLEEPING CAR No 1099.

EQUIPPED FOR CHINESE SERVICE.

109

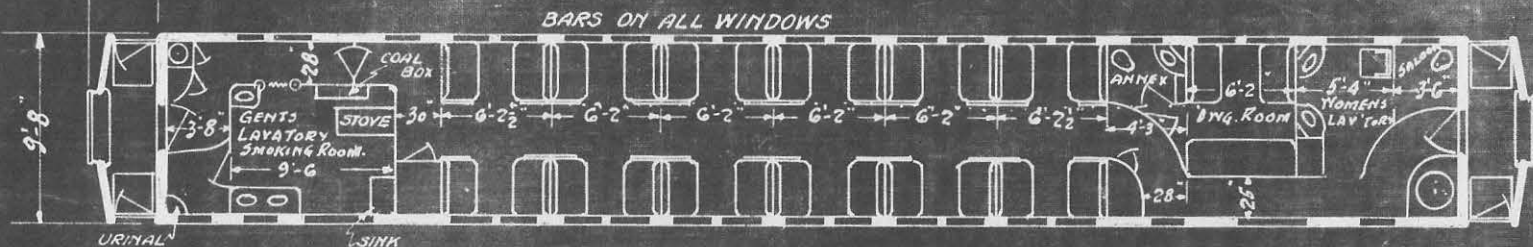
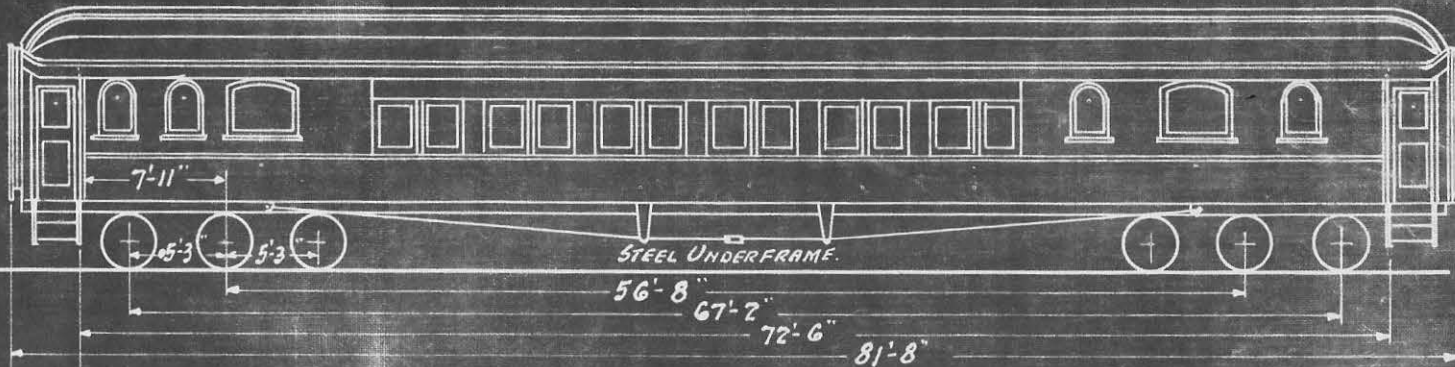
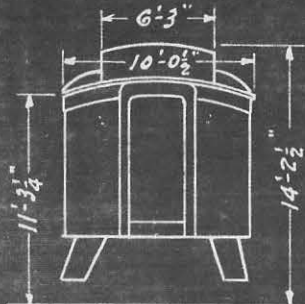

A.F.F. 26736

WEIGHT	15660 LBS.
LENGTH OVER FRAMING	72'-6"
" " BUFFERS	81'-8"
WIDTH " FRAMING	9'-8"
" " CROWN MLDG.	10'-0 1/2"
NUMBER OF SECTIONS	12.
PASSENGERS	48.

TRUCK CENTERS	56'-8"
WHEEL BASE-TRUCK	10'-6"
" " -TOTAL	67'-2"
WHEELS	STEEL 36 DIA.
KIND OF TRUCK	METAL FACED.
JOURNALS SIZE	5" x 9"

AIR BRAKE	2-14 x 12" CYL.
" SIGNAL	" "
HEATER	BAKER
HEATER PIPING	1 1/4 FT
EMPIRE DECK	
WATER SYSTEM	PRESSURE.
CLASP BRAKE	SIMPLEX.

FINISH-EXTERIOR	SHEET STEEL
" -INTERIOR	MAHOGANY & VERMILION.
HEAD LINING	3 PLY VENEER PAINTED
LIGHTING	AXLE GEN. ELECTRIC
DRAFT GEAR	A-S-P-X MINER
COUPLER	SHORT SHANK 9 1/2" BUTT.
BERRYLYTE FIXTURES	

6-1-25. REV. 3-1-26. REV. 12-6-26. REV. 6-1-30. REV. 10-19-38 5-26-43

3754

Built by G.N.Ry.-1948, St. Cloud.

MAIL & BAGGAGE CAR No. 1108

110

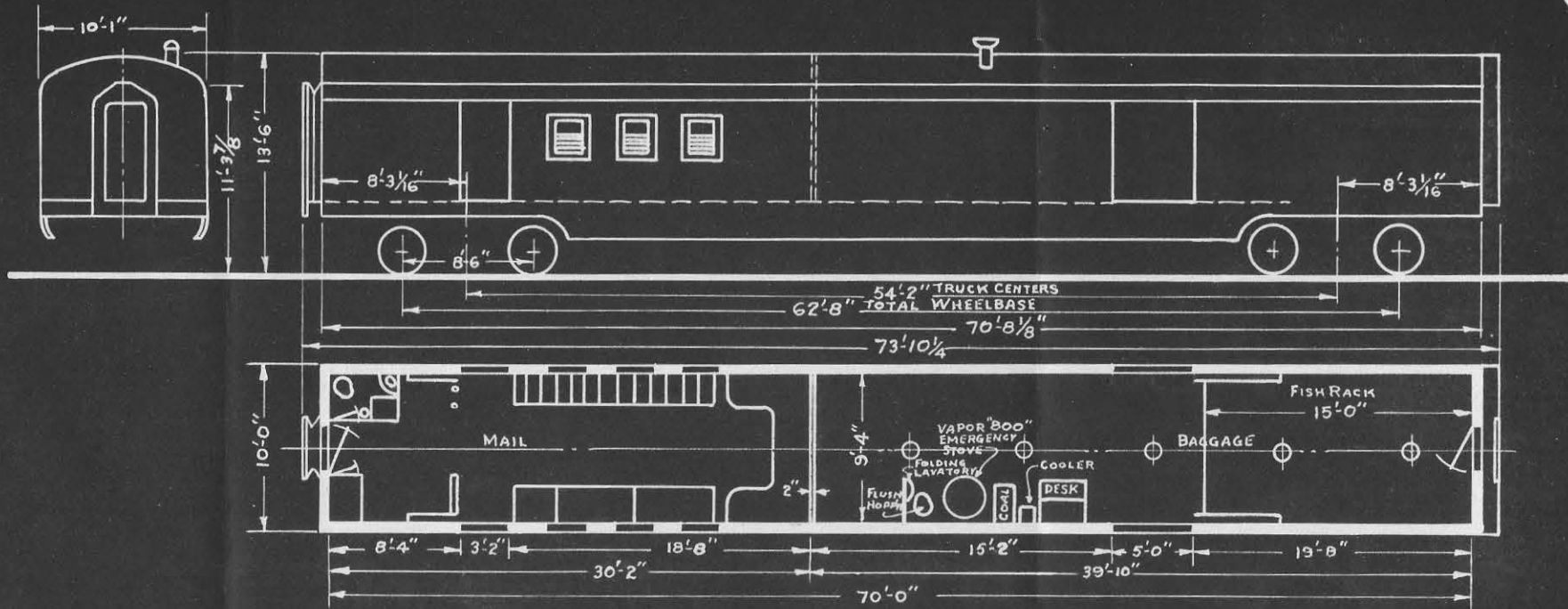

AFE 75803

MB

Weight \_\_\_\_\_ 111400 Lbs.  
 Length Over Framing \_\_\_\_\_ 70'-8"  
 " " Buffers \_\_\_\_\_ 74'-4 1/4"  
 Width " Framing \_\_\_\_\_ 10'-0"  
 " " Crown Midg. \_\_\_\_\_ 10'-1"  
 Seating Capacity \_\_\_\_\_ None  
 Bagg. Capy. \_\_\_\_\_ 40000, Mail Capy. \_\_\_\_\_ 10000

Truck Centers \_\_\_\_\_ 54'-2"  
 Wheelbase- Truck \_\_\_\_\_ 8'-6"  
 " - Total \_\_\_\_\_ 62'-8"  
 Wheels \_\_\_\_\_ Rolled Steel \_\_\_\_\_ 36"  
 Journals \_\_\_\_\_ Timken R. Brg. \_\_\_\_\_ 6" x 11"  
 Kind Of Truck \_\_\_\_\_ Cast Steel

Air Brake \_\_\_\_\_ H.S.C. \_\_\_\_\_ Electro-Pneu  
 " " Cyls. Trk. Mtd. \_\_\_\_\_ 4-12" x 10"  
 " Conditioning \_\_\_\_\_ None  
 Heating \_\_\_\_\_ Vapor  
 Water System \_\_\_\_\_ Gravity  
 Wheel Slip Control \_\_\_\_\_ ABS Co.

Finish- Exterior \_\_\_\_\_ Painted Steel  
 " - Interior \_\_\_\_\_ " "  
 Lighting \_\_\_\_\_ 5 KW. Axle Gen. \_\_\_\_\_ Electric  
 Draft Gear \_\_\_\_\_ DP-6 \_\_\_\_\_ Waugh  
 Coupler \_\_\_\_\_ Short Shank \_\_\_\_\_ Titelock

2-17-48.

5-26-43  
 5-1-24, REV. 12-15-24, REV. 6-1-25, REV. 3-1-26, REV. 6-1-30, REV. 4-16-32, REV. 8-2-38.

BUILT BY A. C. & F. Co. 1910-2000 To 2009  
 " " " " B. & S. 1912-2012 To 2046  
 " " " " " " 1914 2047 To 2089, 1900 To 1931.

## EXPRESS REFRIGERATOR CAR Nos 1900 To 1931, 1932, 2000 To 2089,

EXCEPT 1907, 1923, 2030, 2041, 2012

110

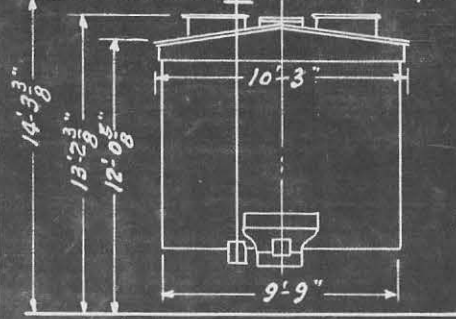

BUILT BY G. N. 1912-2010, 2011  
 " " " " 1919-1918.  
 STEEL UNDERFRAME APPLIED 1924, 1925, 1926.

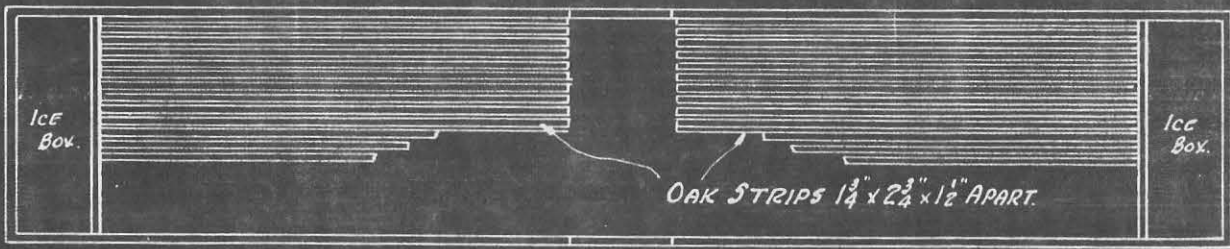
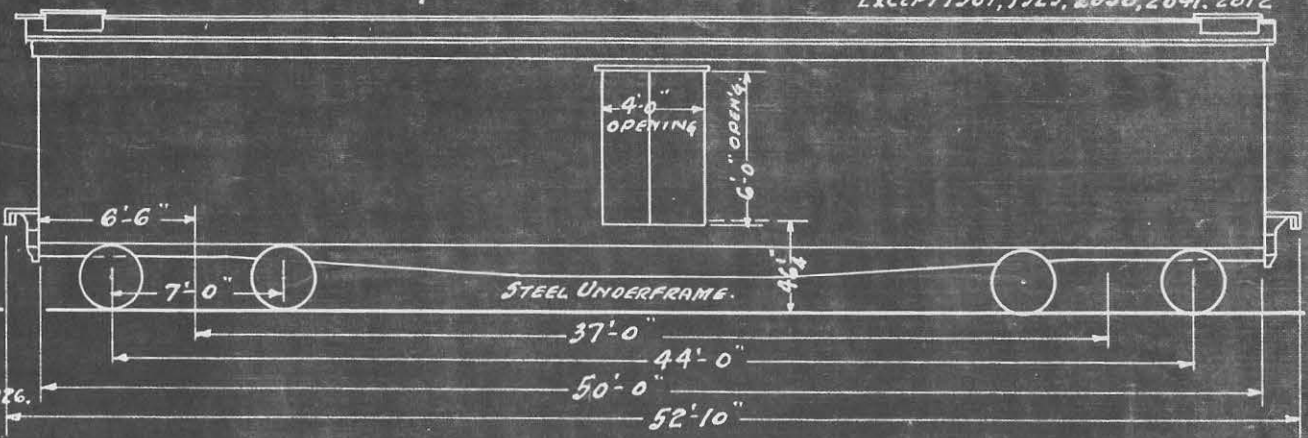

A.F.E 21809, 25559, 26841, 27642.

BR

WEIGHT	78800 LBS.
LENGTH OVER FRAMING	50'-0"
" " BUFFERS	52'-10"
WIDTH " FRAMING	9'-9"
" " LEAVES	10'-3"
CAPACITY	70000 LBS.

TRUCK CENTERS	37'-0"
WHEELBASE-TRUCKS	7'-0"
" " -TOTAL	44'-0"
WHEELS	STEEL TIRED 33" DIA.
JOURNALS SIZE	5 1/2" x 10"
KIND OF TRUCK	METAL.

AIR BRAKE	14x12" CYL.	NEW YORK.
BODY BOLSTER		CAST STEEL.
ROOFING		DOUBLE BOARD.
DRAFT GEAR	A-5-P.	FRICTION MINER.
COUPLER		

SYNON REFRIGERATOR SYSTEM  
 TOTAL ICE CAPACITY 11800 LBS.  
 INSIDE DIMEN'S. 48'-10 1/2" LONG, 8'-10 1/4" WIDE, x  
 7'-6 1/2" HIGH. BETWEEN ICE BOXES 42'-5 1/2"  
 CUBIC CAPY. BETWEEN ICE BOXES 28396 Cu. Ft.



BUILT BY A.C. & F. Co. 1907.

# EXPRESS REFRIGERATOR CAR Nos. 1950 TO 1979.

EXCEPT 1957, 1958, 1974.

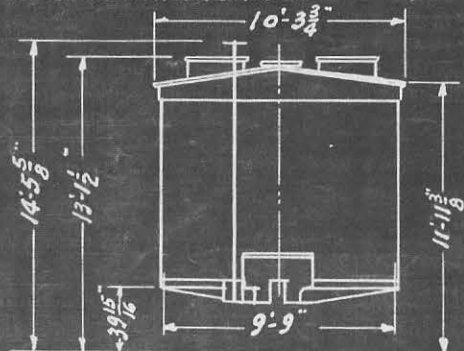

STEEL UNDERFRAME APPLIED 1925.

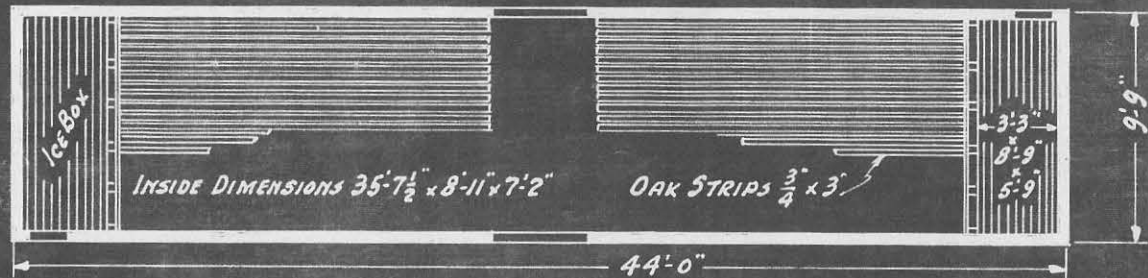
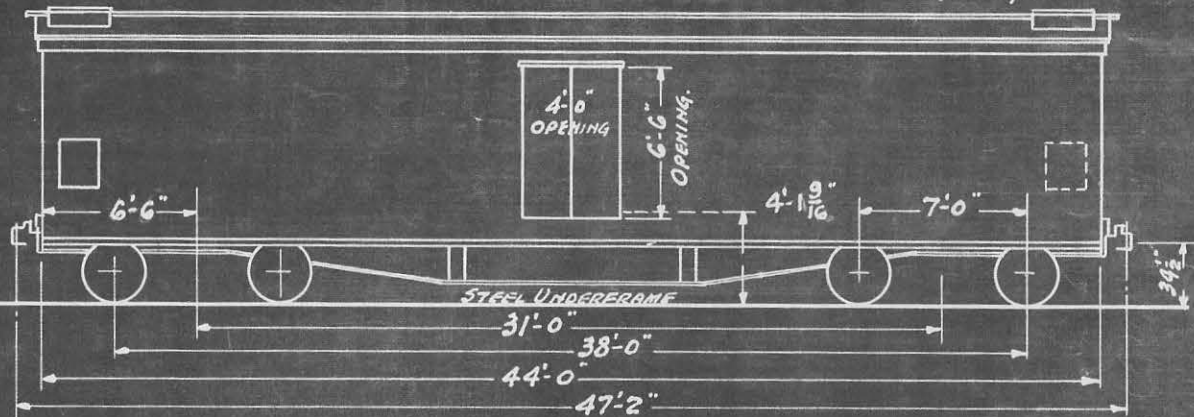

A.F.E 27642.

WEIGHT	71,200 LBS.
LENGTH OVER FRAMING	44'-0"
" " COUPLERS	47'-2"
WIDTH OVER FRAMING	9'-9"
" " EAVES	10'-3 3/4"
CAPACITY	70000 LBS.

TRUCK CENTERS	31'-0"
WHEEL BASE-TRUCK	7'-0"
" " TOTAL	38'-0"
WHEELS	STEEL 33 DIAM.
JOURNALS	SIZE 5 1/2" x 10"
KIND OF TRUCK	METAL

ROOFING	DOUBLE BOARD.
BODY BOLSTER	BUILT UP.
AIR BRAKE	14" x 12" CYL. NEW YORK
DRAFT GEAR	A-5-P. FRICTION MINER

REFR. SYSTEM	"BOHN."
DOORS	LA FLARE.
CUBIC CAPACITY	2272 CU. FT.
ICE CAPACITY TOTAL	12420 LBS.

G-1-25. REV. 3-1-26. REV. 6-1-30. REV. 4-16-32. REV. 9-12-32. 5-26-43

EXPRESS REFRIGERATOR CAR Nos 2090 TO 2139.

112.

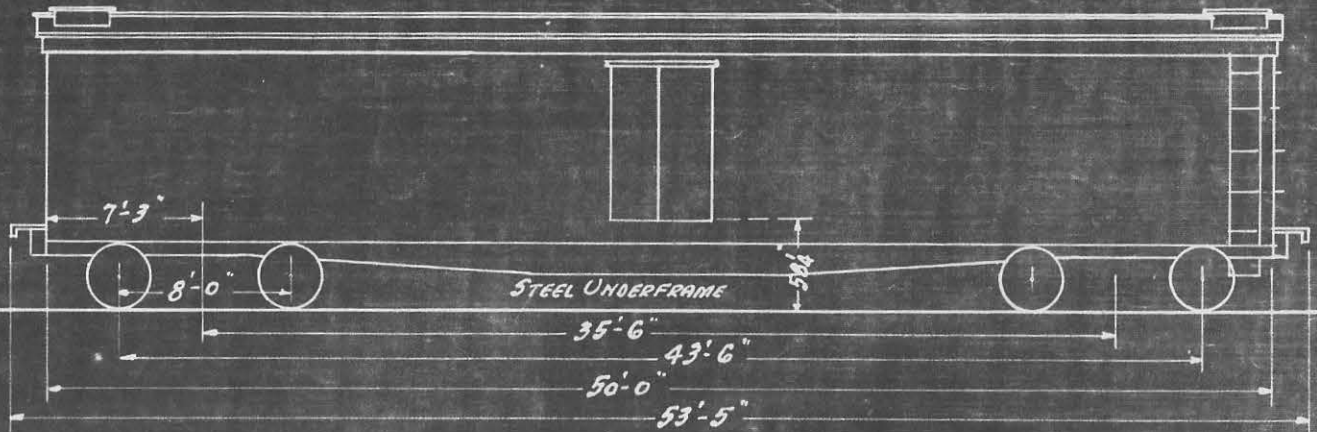
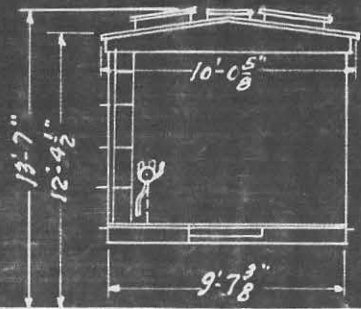

CAR Nos 2091 & 2092 INSULATED WITH BALSAM WOOL. WT. 83630 LBS. BALANCE FLAXLINUM.

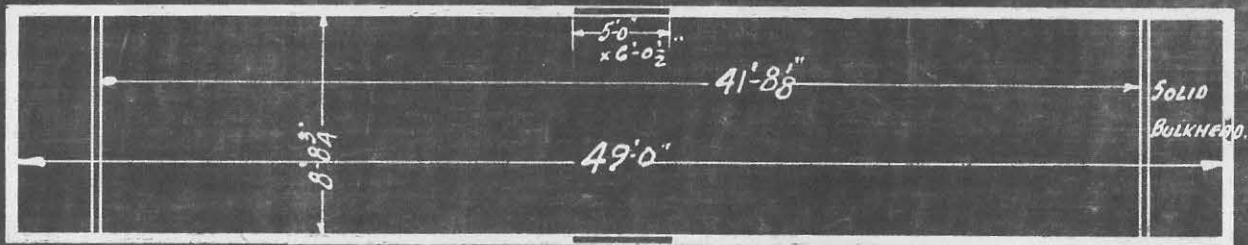

A.F.E. 25057.

WEIGHT	84000 LBS.	TRUCK CENTERS	35'-6"	AIR BRAKE	14" x 12" CYL. NEW YORK.	TOTAL ICE CAPACITY	12600 LBS.
LENGTH OVER FRAMING	50'-0"	WHEEL BASE - TRUCKS	8'-0"	BODY BOLSTER	BUILT UP.	INSIDE DIMENS.	49'-0" LONG 8'-8 3/8" WIDE x
" " BUFFERS	53'-5"	" " - TOTAL	43'-6"	ROOFING	MURPHY V.L.A.	7'-1 5/8" HIGH. BETWEEN ICE BOXES	41'-8 3/8"
WIDTH " FRAMING	9'-7 3/8"	WHEELS	ROLLED STEEL 33" DIA.	DRAFT GEAR	A-5-P FRICTION MINER.	CUBIC CAPY. BETWEEN ICE BOXES	2455 CU. FT.
" " EAVES	10'-0 5/8"	JOURNALS	SIZE 5 1/2" x 10"	COUPLER	TYPE "D" 6" x 8" SHANK.		
CAPACITY	70000 LBS.	KIND OF TRUCK	COMMONWEALTH C.S.	SIDE BEARING	YING		
				DOOR FIXTURES	MINER.		

BR

BUILT BY BARNEY & SMITH 1910  
 STEEL UNDERFRAME & VEST. APPLIED 1922.

# OFFICIAL CAR A-1

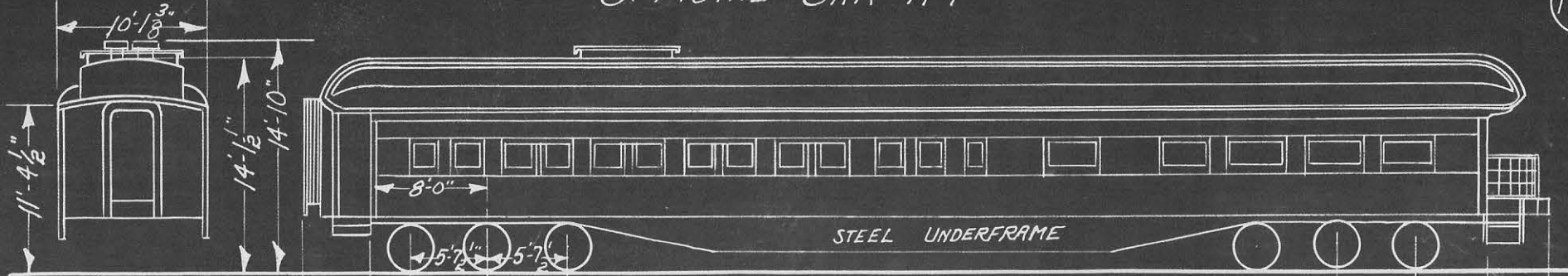

STEEL SHEATHING APPLIED 1924  
 FISH BELLY UNDERFRAME " 1930  
 AIR CONDITIONED 1938.

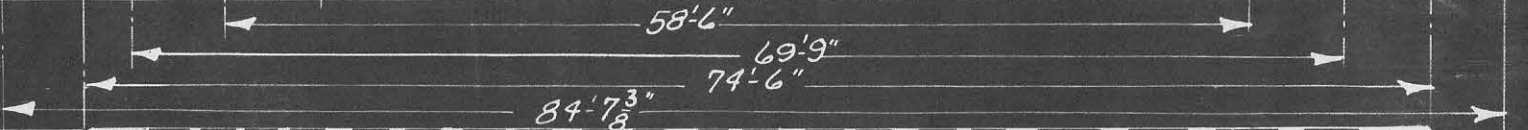

FORMERLY COMP. OBVS. CAR 9021.  
 A.F.E. 20784, 26818, 53905.



2-20-38, REV. 5-2-41 5-26-43

WEIGHT	199080 LB.	TRUCK CENTERS	58'-6"	AIR BRAKES	4-10"x10" CYLS.	OUTSIDE FINISH	SHEET STEEL
" WITH BATT. & ICE	204680 "	" WHEELBASE	11'-3"	AIR SIGNAL	NEW YORK.	INSIDE	" MAHOGANY
LENGTH OVER FRAMING	74'-6"	TOTAL	69'-9"	HEATER	Golds Comb. Double Coil	HEAD LINING	STEEL & 3PLY VENEER.
" " BUFFERS	84'-7 3/8"	WHEELS	ROLLED STEEL 36" DIA.	VAPOR HEAT	MANUAL & AUTO.	LIGHTING	AXEL GEN. 7 1/2 KW.
WIDTH " FRAMING	9'-8"	KIND OF TRUCK	COMMONWEALTH.	CLASP BRAKE	SIMPLEX	RECTIFIER	50 A. 32 V.
" " CROWN MLDG.	10'-1 3/8"	JOURNALS	SIZE 5 1/2"x10"	AIR CONDITIONING	ICE ACT.	DRAFT GEAR	MINER.
INSIDE LENGTH	72'-8 3/4"			SERVICE BOX	FRIGIDAIRE	COUPLER	SWIVEL BUTT.



REV. 12-15-24, REV. 6-1-25, REV. 9-1-26, REV. 1-24-27, REV. 2-6-29, REV. 6-1-30, 5-26-43  
 REV. 6-20-22, REVISED 10-30-15, REV. 10-1-22, FORMERLY A.I. REV. 1-27-23

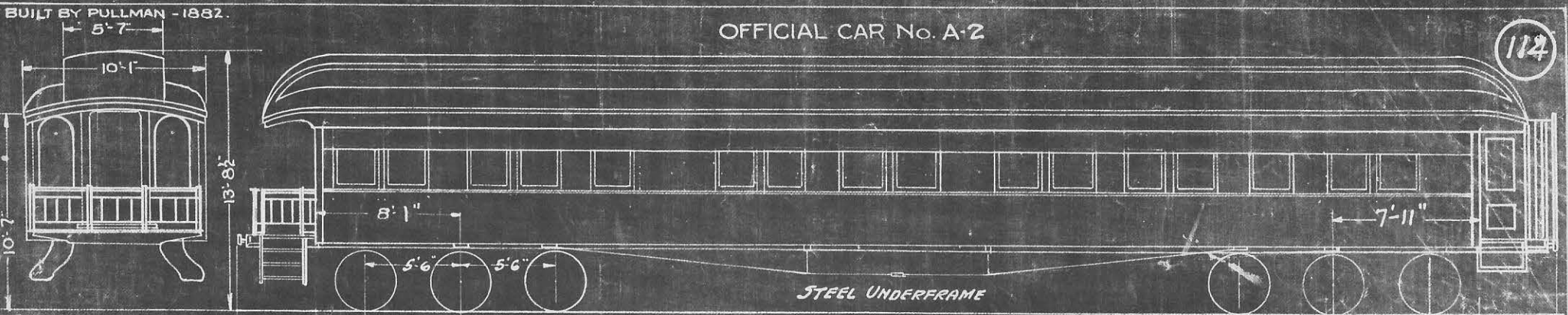

STEEL UNDERFRAME APPLIED 1924.  
 STEEL SHEATHING APPLIED 1927.  
 TRUCKS FORMERLY ON MAIL CAR No 29

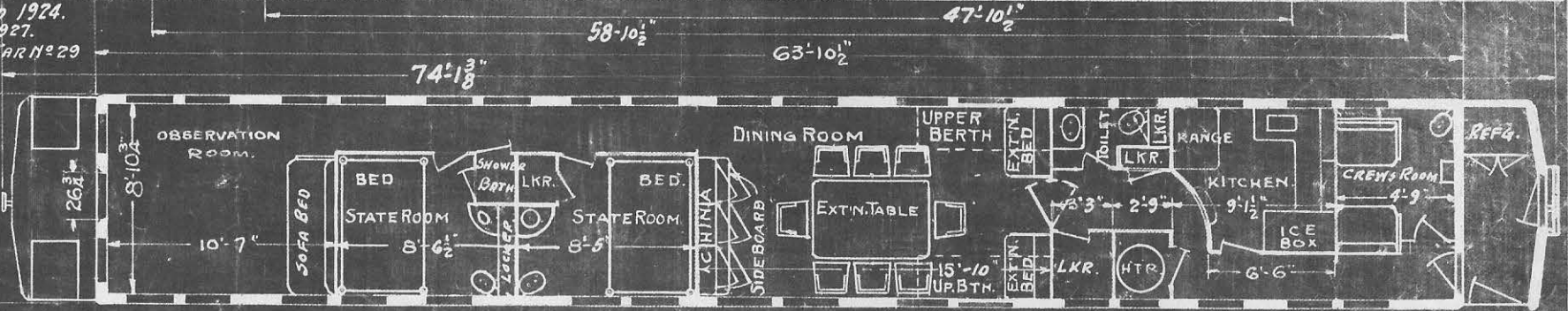

A.F.F. 26676.33040.

WEIGHT, LBS.	154,300.	TRANSOM CENTERS;	47'-10 1/2"	AIR BRAKE, 18" CYL.	NEW YORK CO.	FINISH, EXTERIOR,	SHEET STEEL
LENGTH OVER FRAMING;	63'-10 1/2"	TOTAL WHEEL BASE;	58'-10 1/2"	AIR SIGNAL, (MAKER)	NEW YORK CO.	FINISH, INTERIOR;	OAK & MAHOGANY.
LENGTH OVER BUFFERS;	74'-1 3/8"	TRUCK WHEEL BASE;	11'-0"	HEATER, (MAKER)	BAKER.	HEAD LINING;	OAK & MAHOGANY.
WIDTH OVER FRAMING;	9'-8"	WHEELS, STEEL,	DIAM. 36 1/2"	HEATER PIPING;	DOUBLE COIL COMB.	LIGHTING;	ALEX. GEN. ELECTRIC
WIDTH OVER CROWN M'LD'G;	10'-1"	KIND OF TRUCK	CAST STEEL	CLASP BRAKE	14'-	DRAFT GEAR	MILNER
		JOURNALS, SIZE,	5 1/2" x 10"		622 FT.	COUPLER	SHORT SHANK 9 1/2" BUTT.

BUILT BY B & S. Co. 1906  
 STEEL UNDERFRAME APPLIED & INTERIOR ARR'GT. ADDED 1927.

OFFICIAL CAR No. A-3, 115

115

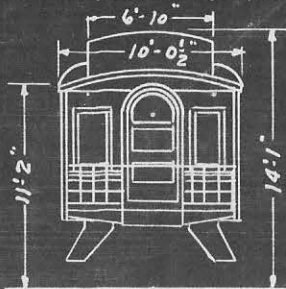

FORMERLY COACH No. 587

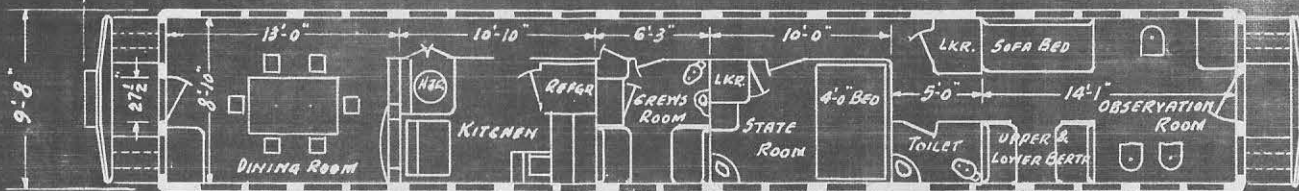
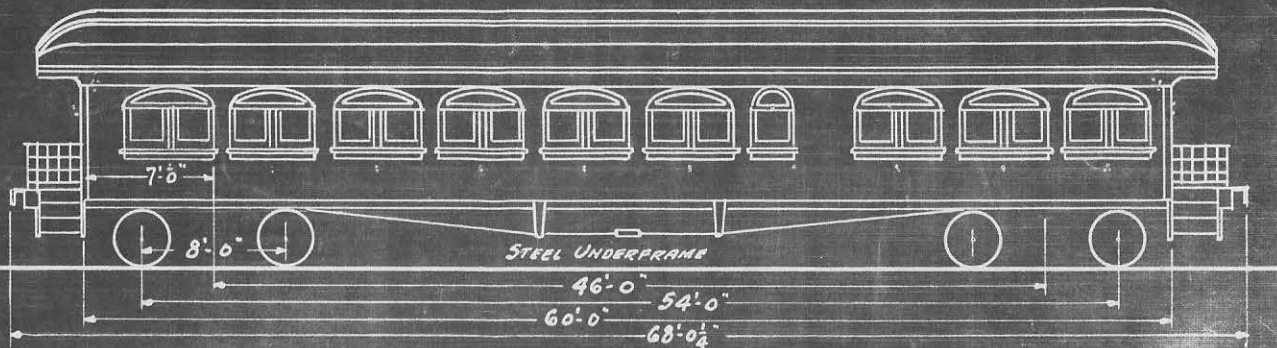

R.F.F. 32960, 33085.

WEIGHT	114900 LBS.	TRUCK CENTERS	46'-0"	AIR BRAKE	16x12" CYL.	FINISH - EXTERIOR	GROOVED SHEATHING.
LENGTH OVER FRAMING	60'-0"	WHEEL BASE - TRUCKS	8'-0"	" SIGNAL		" INTERIOR	VARIOUS WOODS.
" BUFFERS	68'-0"	" TOTAL	54'-0"	HEATER	BAKER.	HEADLINING	3 PLY VENEER PAINTED
WIDTH	9'-8"	WHEELS	ROLLED STEEL 36" DIA.	WATER SYSTEM	GRAVITY & PRESSURE.	LIGHTING	AXLE GEN. ELECTRIC.
" CROWN M'LG.	10'-0 1/2"	JOURNALS - SIZE	5x9"			DRAFT GEAR	A.S.X. MINER
		KIND OF TRUCK	METAL FACED.			COUPLER	SHORT SHANK 9 1/2" BUTT.
						INTERIOR PAINTED	ORIENTAL LTD. COLOR.

2-10-27. REV. 11-27. REV. 6-1-30. REV. 9-30-33. 5-26-43

BUILT BY B & S. Co. 1906.  
 STEEL UNDERFRAME APPLIED & INTERIOR ARRANG. ADDED 1927.

# OFFICIAL CAR No A-5.

116.

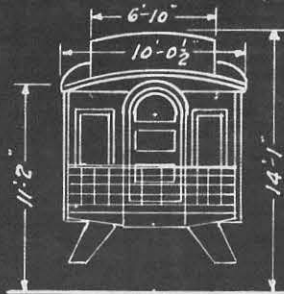

FORMERLY COACH No 585

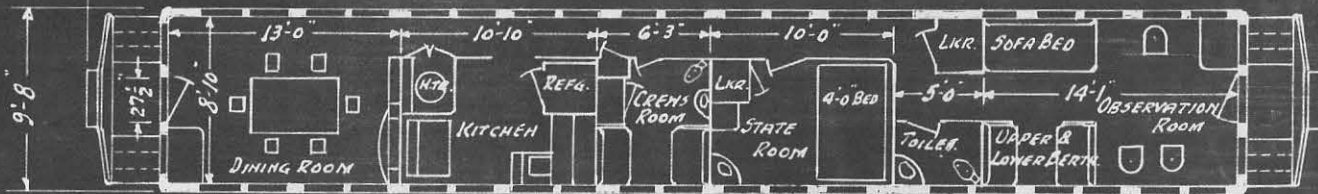
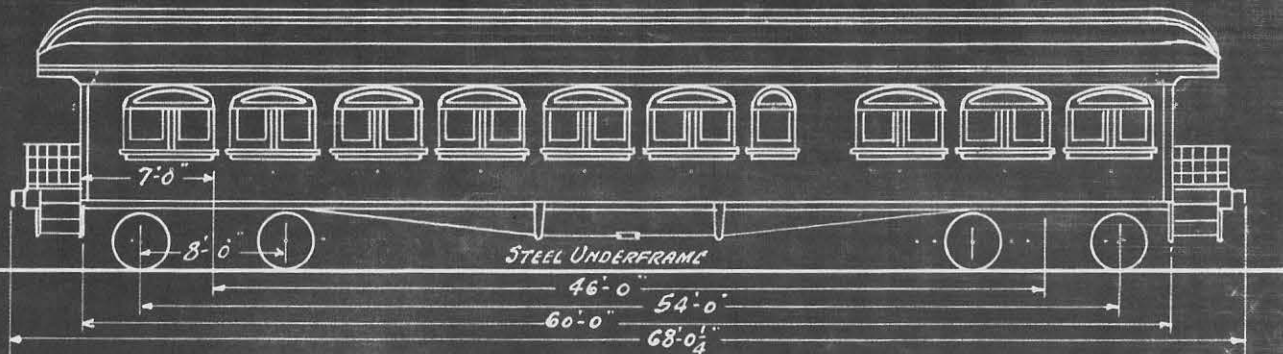

A.F.E. 32960, 33085.

WEIGHT	116400 LBS.
LENGTH OVER FRAMING	60'-0"
" " BUFFERS	68'-0 1/4"
WIDTH " FRAMING	9'-8"
" " CROWN MLDG.	10'-0 1/2"

TRUCK CENTERS	46'-0"
WHEEL BASE - TRUCKS	8'-0"
" " TOTAL	54'-0"
WHEELS - ROLLED STEEL	36" DIA.
JOURNALS - SIZE	5 x 9"
KIND OF TRUCK	METAL FACED

AIR BRAKE	16" x 12" CYL
" SIGNAL	"
HEATER	BAKER
WATER SYSTEM	GRAVITY & PRESSURE.

FINISH - EXTERIOR	GROOVED SHEATHING.
" INTERIOR	VARIOUS WOODS.
HEADLINING	3PLY VENEER PAINTED
LIGHTING	AXLE GEN. ELECTRIC
DRAFT GEAR	A. S. X MINER
COUPLER	SHORT SHANK 9 1/8" BUTT.

INTERIOR PAINTED - ORIENTAL LTD. COLOR.

11-1-27. REV. 6-1-30. REV. 9-30-33. 5-26-43



BUILT BY B. & S. 1911  
 STEEL UNDERFRAME, SHEATHING & VESTIBULE APPLIED 1923.  
 INTERIOR REBUILT 1924 & 1926.

# EXHIBIT OFFICIAL CAR NO. A. 7.

117.

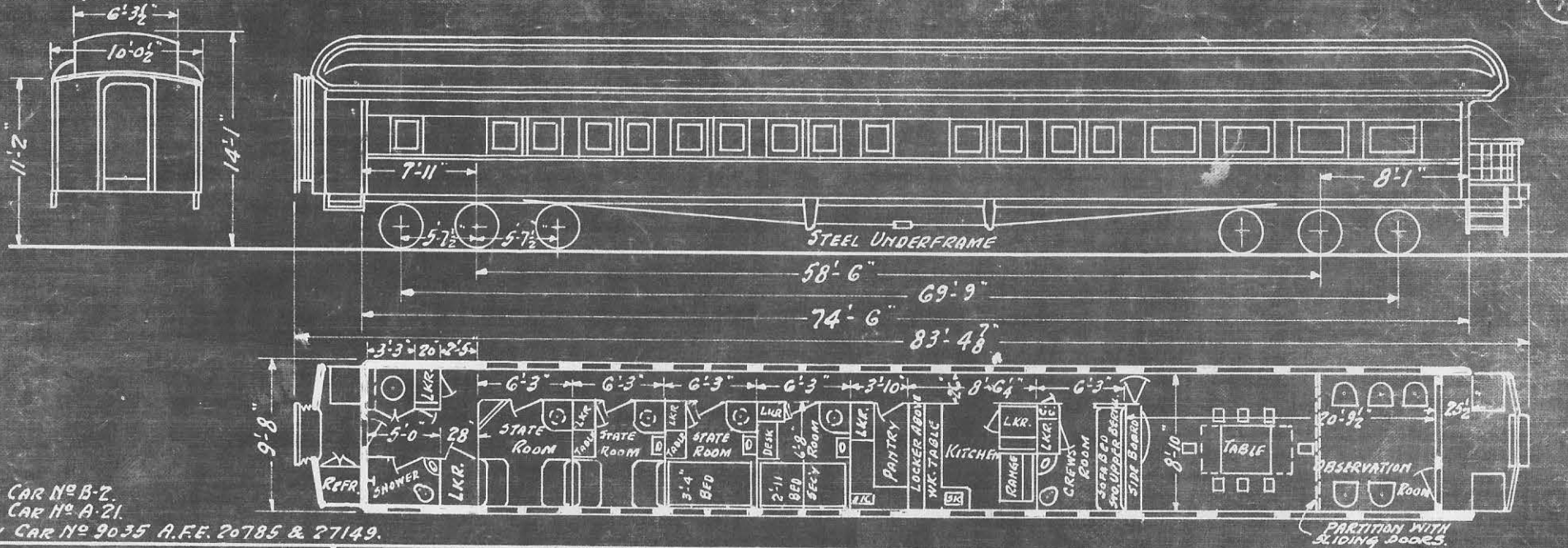

FORMERLY CAR NO. B-2.  
 FORMERLY CAR NO. A-21.  
 FORMERLY CAR NO. 9035 A.F.E. 20785 & 27149.

WEIGHT	177800 LBS.	TRUCK CENTERS	58'-6"	AIR BRAKE	2-16x12 Cyl. New York Co.	FINISH EXTERIOR	STEEL SHEATH'G.
LENGTH OVER FRAMING	74'-6"	TOTAL WHEEL BASE	69'-9"	AIR SIGNAL	" " "	" INTERIOR	VARIOUS WOODS
" " BUFFERS	83'-4 7/8"	TRUCK	11'-3"	HEATER	GOLDS COMB. DOUBLE COIL	HEAD LINING	3 PLY VENEER PAINT'D.
WIDTH	9'-8"	WHEELS	STEEL TIRED - DIAM. 36.	HEATER PIPING	1 1/4" 600 FT.	LIGHTING	AXLE RIG - ELECTRIC.
" " FRAMING	9'-8"	NUMBER OF WHEELS	TWELVE.	EMPIRE DECK		DRAFT GEAR	MINER
" " CROWN MLDG.	10'-0 1/2"	JOURNALS - SIZE	5 1/2 x 10"	CLASP BRAKE	SIMPLEX	COUPLER	SWIVEL BUTT.
		KIND OF TRUCK	COMMONWEALTH.	WATER SYSTEM	PRESSURE.		

REV. 6-1-30. REV. 3-3-34. REV. 4-25-41. 5-26-43  
 12-5-24. (REV. 12-22-24. REV. 5-26-25. REV. 3-1-26. REV. 3-20-26. REV. 10-6-26. REV. 2-5-27. REV. 8-10-27)

BUILT BY B. & O. 1909.

STEEL UNDERFRAME, SHEATHING & VESTIBULE APPLIED 1923.

INTERIOR REARRANGED 1927-1930.

# OFFICIAL CAR No A-8.

118.

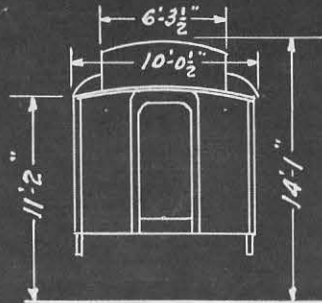

CHANGED FROM 1107 TO A-8-1930.

TRUCKS FROM MAIL CAR No 34.

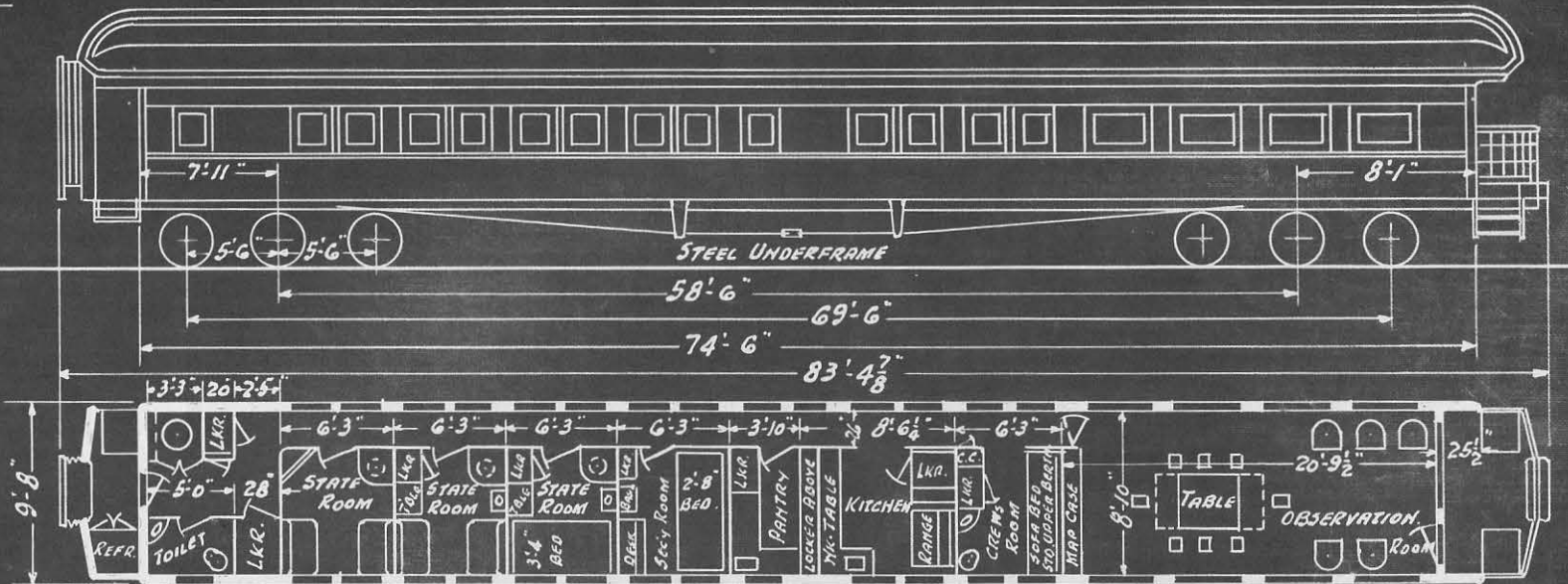

2-8-30. REV. 6-1-30. 5-26-43

WEIGHT	16110 LBS.	TRUCK CENTERS	58'-6"	AIR BRAKE	2-16" x 12" CYL.	FINISH EXTERIOR	STEEL SHEATHING
LENGTH OVER FRAMING	74'-6"	TOTAL WHEEL BASE	69'-6"	HEATER	GOLD'S COMB. DOUBLE COIL	" INTERIOR	VARIOUS WOODS.
" " BUFFERS	83'-4 7/8"	TRUCK " "	11'-0"	HEATER PIPING	1 1/4" 600 FT.	HEAD LINING	3 PLY VENEER PAINTED.
WIDTH " FRAMING	9'-8"	WHEELS	ROLLED STEEL 36" DIA.	CLASP BRAKE	AMERICAN.	LIGHTING	AXLE RIG ELECTRIC.
" " CROWN MLDG.	10'-0 1/2"	KIND OF TRUCK	CAST STEEL.	WATER SYSTEM	PRESSURE.	DRAFT GEAR	MINER
		JOURNALS SIZE	5" x 9"	VAPOR HEAT		COUPLER	SHORT SHANK 9 3/8" BUTT.

BUILT BY PULL CO. 1905. REBUILT BY G.N.RY 1924.

# OFFICIAL CAR A-10.

119.

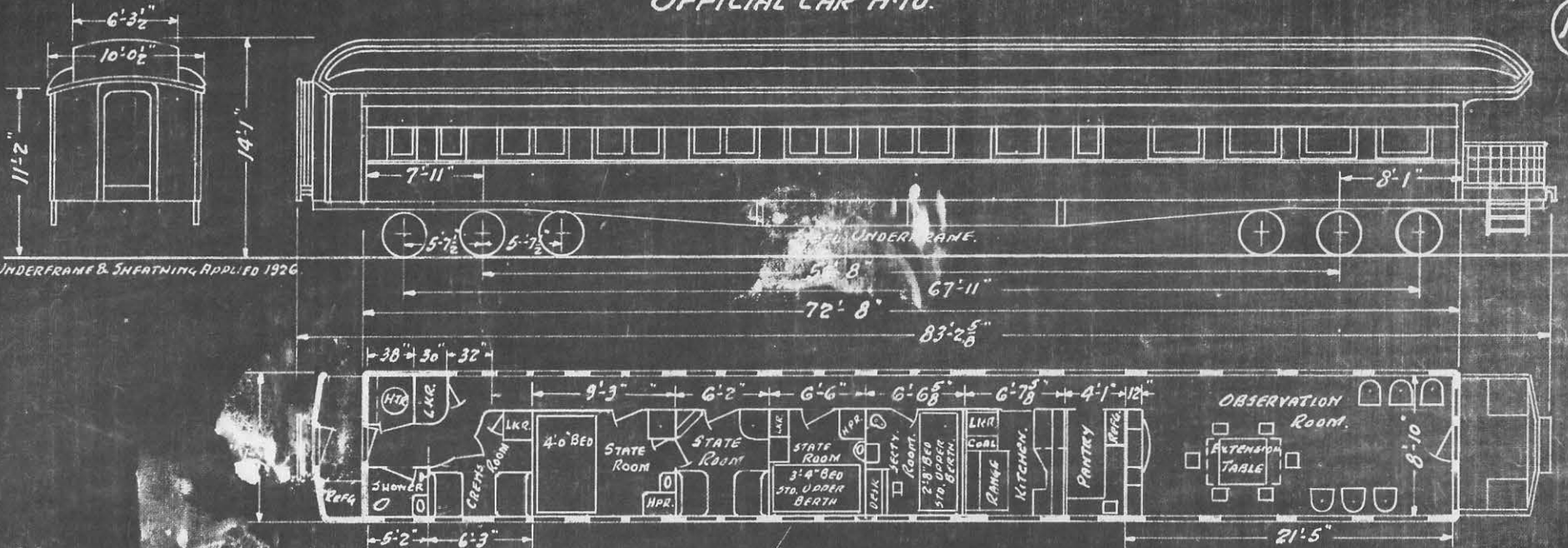

STEEL UNDERFRAME & SHEATHING APPLIED 1926.

A.F.E 25491. FORMERLY OBS. CAR No. 9006.

WEIGHT	171400 LBS.	TRUCK CENTERS	56'-8"	AIR BRAKES	18" x 12" CYL.	FINISH-EXTERIOR	STEEL SHEATHING.
LENGTH OVER FRAMING	72'-8"	WHEELBASE-TRUCK	11'-3"	" SIGNALS	"	" - INTERIOR	VARIOUS WOODS.
" " BUFFERS	83'-2 5/8"	" " -TOTAL	67'-11"	BAKER HEATER	GOLDS COMB'D. 592 FT. 1 1/2" PIPE.	" - HEAD LINING	PAINTED.
WIDTH " FRAMING	9'-8"	KIND OF TRUCKS	COMMON MILN.	VAPOR HEAT	"	LIGHTING	AXLE GEN. ELECTRIC.
" " CROMIN MLDG.	10'-0 1/2"	WHEELS	ROLLED STEEL - DIA. 36"			DRAFT GEAR	MINER
		JOURNALS	5 1/2" x 10"			COUPLER	SHORT SHANK 9 1/2" BUTT.

4-1-24. REV. 6-1-25. REV. 3-1-26. REV. 5-27-27. REV. 6-1-30. 5-26-43



BUILT BY AM. CAR & FRY CO. 1900.  
 UNDERFRAME APPLIED 1923. STEEL SHEATHING APPLIED 1924.

# OFFICIAL CAR A-18

120

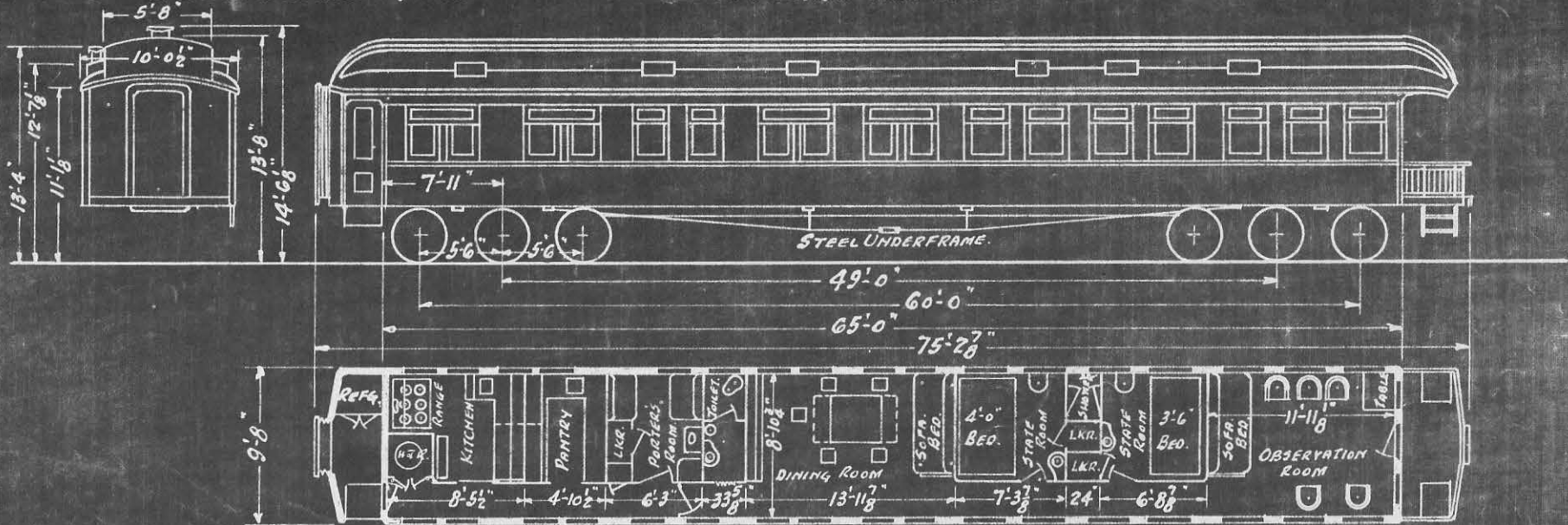

REV. 3-1-26. REV. 10-5-27. REV. 6-1-30. 5-26-43  
 4-1-24 FORMERLY A-18. REV. 5-1-24. FORMERLY A-30 REV. 5-26-25. REV. 6-1-25

## A.F.E. No 25490. TRUCKS FORMERLY ON MAIL CAR No 24.

WEIGHT	151400 LBS.	TRUCK CENTERS	49'-0"	AIR BRAKE	LN 18' CYL.	NEW YORK	OUTSIDE FINISH	STEEL SHEATHED.
LENGTH OVER FRAMING	65'-0"	WHEELBASE - TRUCKS	11'-0"	AIR SIGNAL	" "	" "	INSIDE	MAHOGANY & OAK
" BUFFERS	75'-2 3/8"	" TOTAL	60'-0"	CLASP BRAKE	AMERICAN	" "	HEAD LINING	CANVAS COVERED.
WIDTH " FRAMING	9'-8"	WHEELS ROLLED STEEL	DIA. 36	BAKER HEATER -			LIGHTING	AXLE GEN. ELECTRIC.
" " CROWN MLDG.	10'-0 1/2"	JOURNALS	5 1/2" x 10"	VAPOR HEAT.			VENTILATORS	GARLAND.
		KIND OF TRUCK	ALL STEEL.	WATER SYSTEM	GRAVITY & PRESSURE.		DRAFT GEAR	MINER

COUPLER — SHORT SHANK — 9 1/2" BUTT.

BUILT BY G.M.R.V. 1912

# OFFICIAL CAR NO A-20

121

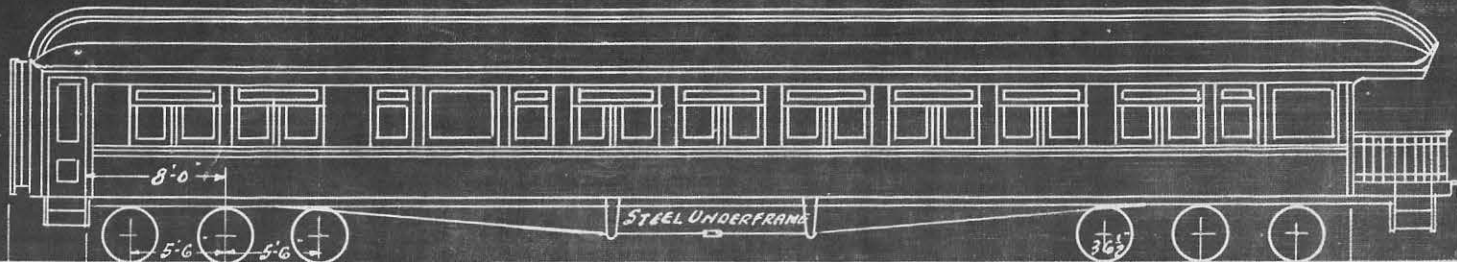
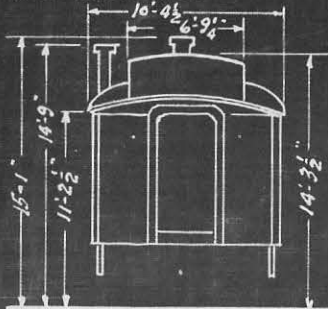

STEEL UNDERFRAME & VEST. APPLIED 1922.  
STEEL SHEATHING APPLIED 1924.  
INTERIOR REARRANGED 1927.

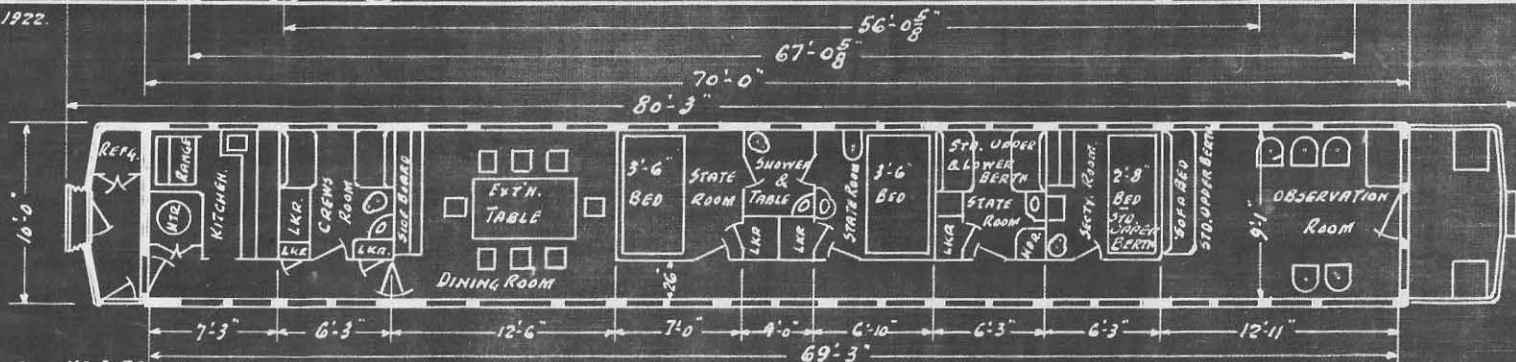

A.F.E 19167, 26622. FORMERLY CAR NO A-28.

WEIGHT	172700 LBS.	TRUCK CENTERS	56'-0 5/8"	AIR BRAKE	18" x 12" CYL.	NEW YORK	FINISH EXTERIOR	SHEET STEEL	
LENGTH OVER FRAMING	70'-0"	WHEEL BASE TRUCK	11'-0"	" SIGNAL	"	"	" INTERIOR	MAHOGANY	
" " BUFFERS	80'-3"	" " TOTAL	67'-0 5/8"	" BRAKE	L-3 TRIPLE VALVE	"	" HEAD LINING	3 PLY VENEER PAINTED	
WIDTH " FRAMING	10'-0"	WHEELS ROLLED STEEL	36 1/2" DIA.	" " "	AM. SLACK ADJUSTER	"	LIGHTING	AXLE GEN.	ELECTRIC
" " CROWN MLOG.	10'-4 1/2"	JOURNALS SIZE	5 1/2" x 10"	BAKER HEATER	GOLDS COMBINED	"	CLASP BRAKE	SIMPLEX	"
		KIND OF TRUCK	PULLMAN TYPE.	VAPOR HEAT.			DRAFT GEAR	MINER	"
							COUPLER	SHORT SHANK	9 5/8" BUTT.

2-26-27. REV. 3-9-27 No CHANGED FROM A-28. REV. 11-1-27. REV. G. 130 5-26-43.

BUILT AT ST. PAUL, 1905  
 STEEL UNDERFRAME APPLIED 1922.  
 STEEL SHEATHING APPLIED 1925.

OFFICIAL CAR NO A 22.

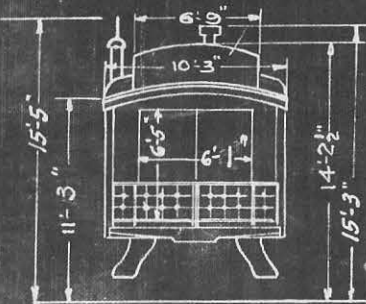

AUTO DOOR DIMENSIONS  
 CLEAR OPENING 6'-5" HIGH x  
 6'-1" WIDE.

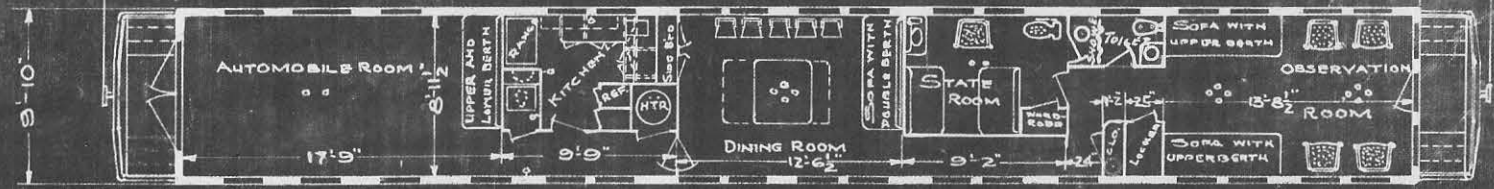
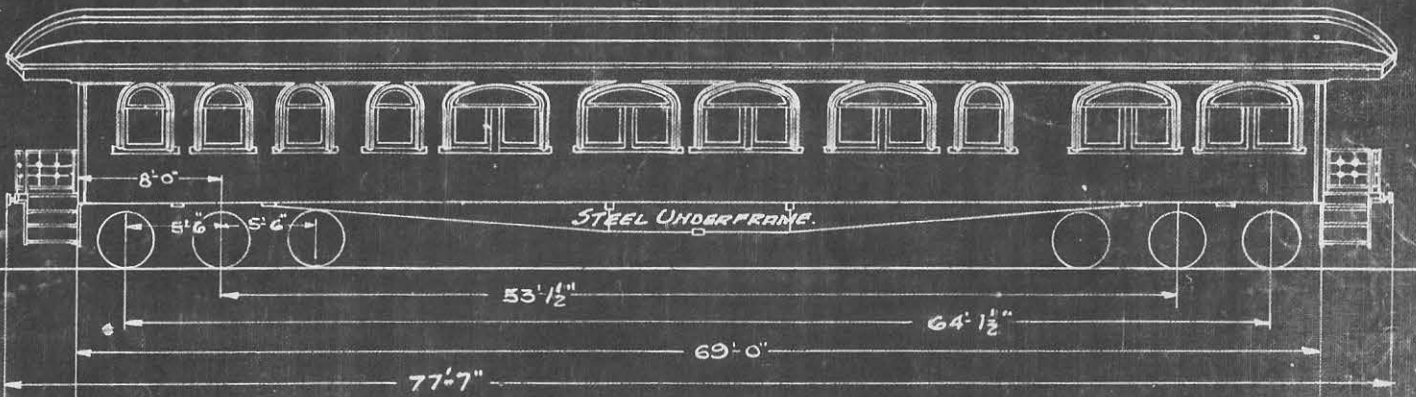

A.F.E 29015.  
 A.F.E 18899 TRUCKS FORMERLY ON MAIL CAR NO 28.

WEIGHT, LBS., ——— 161,700.	TRANSOM CENTERS, ——— 53'-1/2"	AIR BRAKE, ——— 18" x 12" CYL.	FINISH, EXTERIOR, ——— SHEET STEEL.
LENGTH OVER FRAMING, ——— 69'-0"	TOTAL WHEEL BASE, ——— 64'-1/2"	AIR SIGNAL, ———	FINISH, INTERIOR, ——— BIRCH & MAHOGANY.
LENGTH OVER BUFFERS, ——— 77'-7"	TRUCK WHEEL BASE, ——— 11'-0"	HEATER, (MAKER) ——— BAKER.	HEAD LINING, 3 PLY VENEER PAINTED.
WIDTH OVER FRAMING, ——— 9'-10"	WHEELS, ——— STEEL, ——— DIAM. 36 1/2"	CLASP BRAKES ——— AMERICAN	LIGHTING, ELECTRIC ——— AXLE GENERATOR
WIDTH OVER CROWN M'LD'G, ——— 10'-3"	KIND OF TRUCK ——— CAST STEEL.	HEATER PIPING, ——— 1/4" ——— 500 FT.	DRAFT GEAR ——— MINER
	JOURNALS, SIZE. ——— 5 1/2" x 10"		COUPLER ——— 1-SHORT SHANK ——— 9 1/8" BUTT 1-LONG SHANK

REV. 11-2-26. REV. 2-1-28. REV. 6-1-30. REV. 12-20-32. 5-26-43  
 REV. 6-8-22. REV. 11-20-22 SHOWER BATH ADDED. REV. 5-1-24. REV. 12-15-24. REV. G-1-25. REV. 3-1-26.



REBUILT G.N.R.V 1930.  
STEEL UNDERFRAME APPLIED 1927.

# OFFICIAL CAR NO A-23.

123

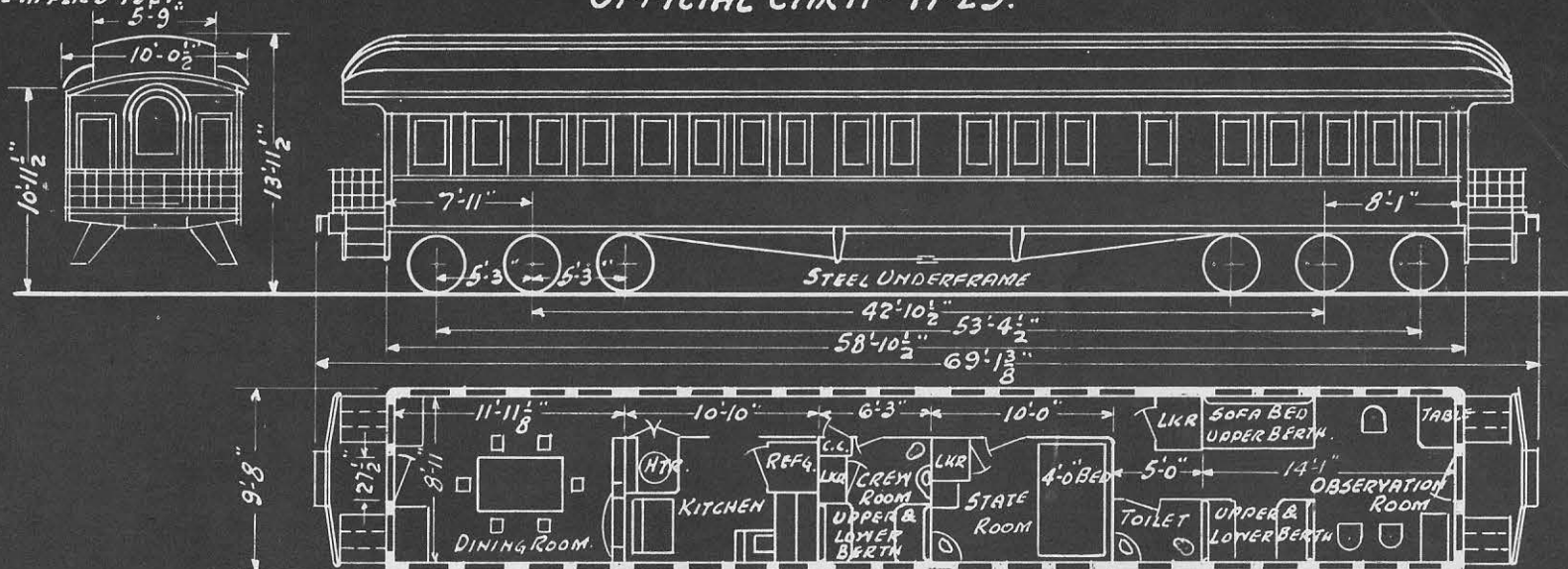

A.F.E 33770.

WEIGHT	123200 LBS.	TRUCK CENTERS	42'-10 1/2"	AIR BRAKE	18" x 12" CYL.	FINISH - EXTERIOR	GROOVED SHEATHING
LENGTH OVER FRAMING	58'-10 1/2"	WHEEL BASE - TRUCKS	10'-6"	" SIGNAL		" - INTERIOR	VARIOUS WOOD.
" " BUFFERS	69'-1 3/8"	" " - TOTAL	53'-4 1/2"	HEATER	BAKER.	HEADLINING	3 PLY VENEER PAINTED
WIDTH " FRAMING	9'-8"	WHEELS	ROLLED STEEL 36" DIA.	WATER SYSTEM	GRAVITY & PRESSURE.	LIGHTING	AXLE GEN. ELECTRIC.
" " CROWN MLDG.	10'-0 1/2"	JOURNALS - SIZE	5" x 9"			DRAFT GEAR	A.S.P.X. MINER.
		KIND OF TRUCK	METAL FACED.			COUPLER	SHORT SHANK 9 1/8" BUTT.
						INTERIOR PAINTED	

5-27-31. REV. 12-18-31. 5-26-43

5-26-43 REV. 10-1-22 REV. 5-1-24 REV. 6-1-25 REV. 3-1-26 REV. 9-16-30 REV. 4-14-38 REV. 5-2-41

# OFFICIAL CAR A25.

124

REBUILT BY G. N. RY. 1908  
 BUILT BY B. & S. 1883.  
 STEEL UNDERFRAME APPLIED 1923.

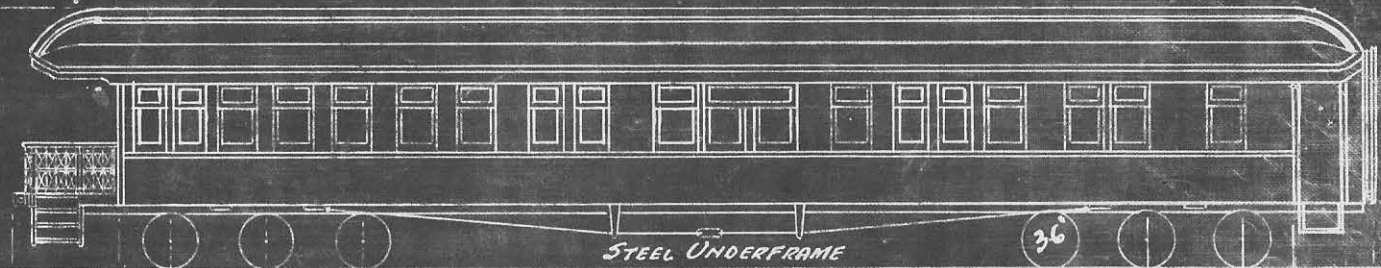
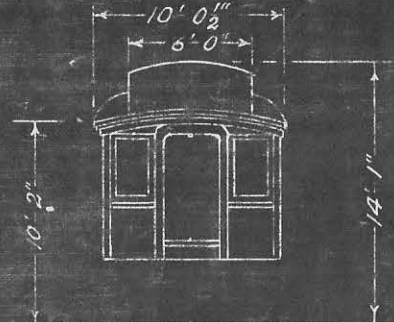

STEEL SHEATHING APPLIED 1925.

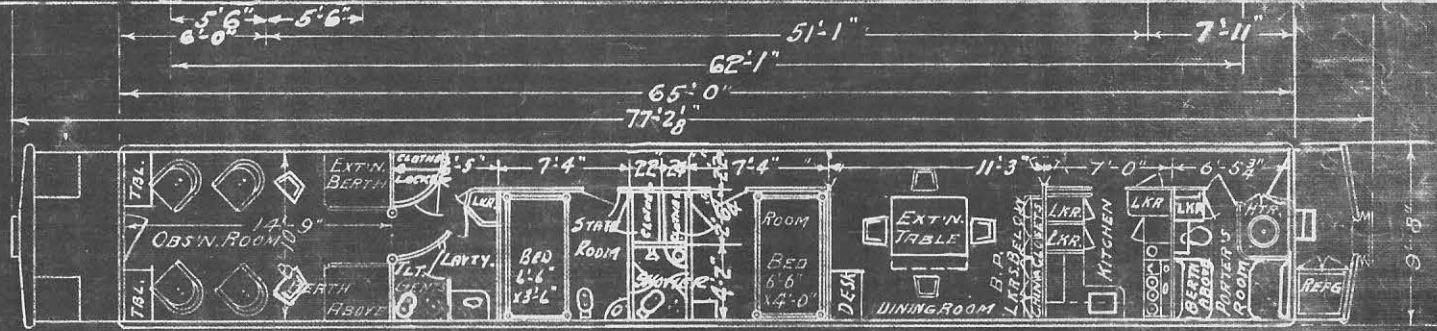

A.F.E. 22002, 23862, 19749.

WEIGHT <b>163300 Lbs.</b> LENGTH OVER FRAMING 65'-0" " " BUFFERS 77'-2 1/2" WIDTH " FRAMING 9'-8" " " CROWN MLDS. 10'-0 1/2" " " DECK 6'-0"	BOLSTER CENTERS 51'-1" TOTAL WHEEL BASE 62'-1" TRUCK " " 11'-0" STEEL TIED WHEELS, 36" DIAM. SIX WHEEL TRUCKS PULLMAN TYPE JOURNALS M.C.B. 5 1/2" x 10"	AIR BRAKES 18x12" CYL. AIR SIGNAL BAKER HEATER + VAPOR " PIPING 1/4" DIAM. 2-9", 3-12", 1-16" ELECTRIC FANS. 4-9", 2-12" EXHAUST "	OUTSIDE FINISH SHEET STEEL. INSIDE " MAHOGANY. HEADLINING STEEL. LIGHTING ELECTRIC AXLE LIGHT DRAFT GEAR A-5-P MINER COUPLER SWIVEL BUTT. CLASP BRAKES.
--	--	---	---

BUILT BY B. & S. 1911  
STEEL SHEATHED & UNDERFRAME APPLIED 1925.

# OFFICIAL CAR NO A-28

125.

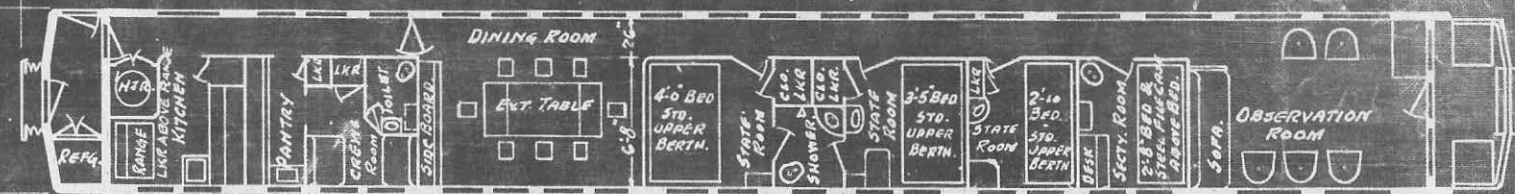
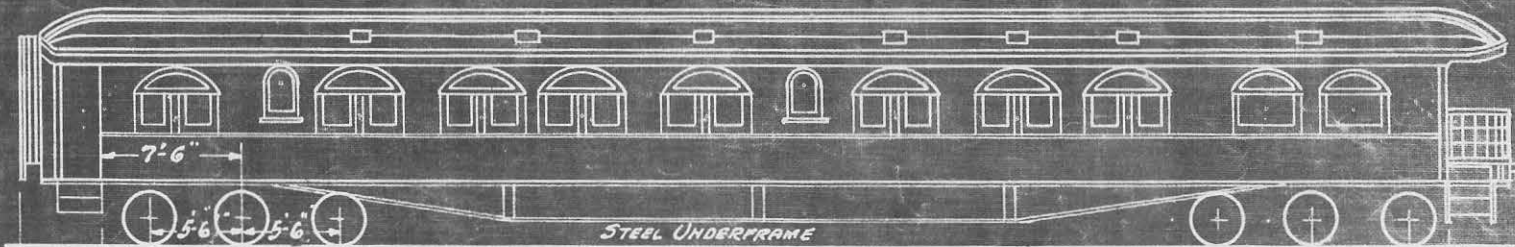
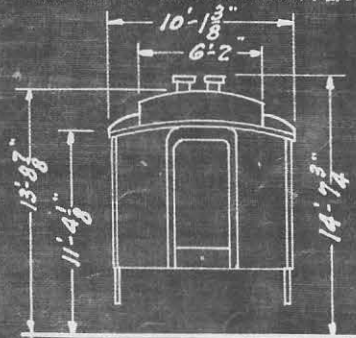

FORMERLY CAR NO 917. FORMERLY CAR NO A-30.

WEIGHT	200,000 LBS	TRUCK CENTER	59'-6"	AIR BRAKE	4-10"x12" CYLS. NEW YORK	OUTSIDE FINISH	SHEET STEEL
LENGTH OVER FRAMING	74'-6"	WHEELBASE-TRUCK	11'-0"	AIR SIGNAL	"	INSIDE	MAHOGANY.
" " BUFFERS	84'-6 1/2"	" " -TOTAL	70'-6"	CLASP BRAKE	SIMPLEX	HEAD LINING	STEEL & 3 PLY VENEER PAINTED
WIDTH " FRAMING	9'-8"	WHEELS	ROLLED STEEL 36" DIA.	BAKER HEATER	"	LIGHTING	AXLE GEN. ELECTRIC
" " CROWN MLDG.	10'-1 3/8"	JOURNALS	SIZE 5 1/2" x 10"	VAPOR HEAT	"	DRAFT GEAR	MINER
WEIGHT WITH BATTERY	202,000	KIND OF TRUCK	PULLMAN TYPE	WATER SYSTEM	GRAVITY & PRESSURE	COUPLER	SWIVEL BUTT.
				AIR CONDITIONING	ICE ACTIVATED.	RECTIFIER	50A. 32V.
				SERVICE BOX	FRIGIDAIRE		

REV. 12-18-31. REV. 5-15-36. REV. 2-4-38. REV. 5-2-41. 5-26-43.  
 REV. 3-9-27. NO CHANGED FROM NO A-30. REV. 5-20-27. REV. 11-1-27. REV. 5-20-28. REV. 5-29-31. REV. 12-3-31.  
 5-29-25. REV. 6-25. REV. 10-23-25. REV. 3-1-26. REV. 8-24-26. REV. 1-26-27. REV. 6-1-30.



BUILT BY B&S 1911, CONVERTED TO BUSINESS CAR  
 STEEL SHEATHED & UNDERFRAMED 1927, AIR CONDITIONED 1937.

# OFFICIAL CAR A-30

AUG. 27, 1937. REV. 11-26-37; 2-4-38. REV. 5-2-41 5-26-43

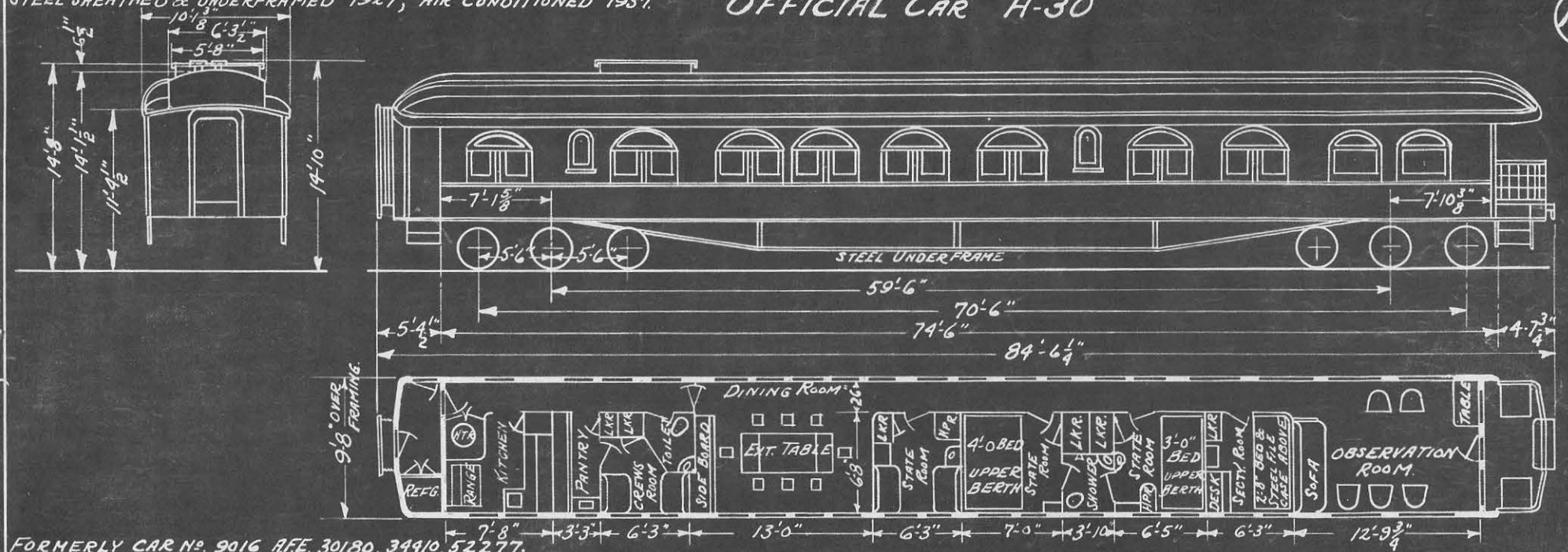

FORMERLY CAR NO. 9016 A.F.E. 30180, 34910, 52277.

WEIGHT	205500 LBS.	TRUCK CENTERS	59'-6"	AIR BRAKE	4-10"x12" CYL. AB.	NEW YORK	OUTSIDE FINISH	SHEET STEEL
WEIGHT LOADED - BAT.	208600 "	WHEEL BASE TRUCK	11'-0"	AIR SIGNAL	" "	" "	INSIDE	MAHOGANY
LENGTH OVER FRAMING	74'-6"	" " TOTAL	70'-6"	CLASP BRAKE	" "	" "	HEAD LINING	3 PLY VENEER
" " BUFFERS	84'-6 1/4"	WHEELS	36" DIA	BRAKE CYLS.	" "	" "	LIGHTING	AXLE GEN.
" " FRAMING	9'-8"	JOURNALS SIZE	5 1/2"x10"	VAPOR HEAT	" "	" "	MOTOR GEN. - AUX. UNIT	220 VOLT MOTOR
" " CROWN MLDG.	10'-1 3/8"	KIND OF TRUCK	PULLMAN TYPE.	WATER SYSTEM	" "	" "	SERVICE BOX	FRIGIDAIRE
AIR COND. - DUCT, OUTSIDE	SINGLE.			AIR COND.	" "	" "	DRAFT GEAR	" "
				BAKER HEATER	" "	" "	COUPLER	MINER SWIVEL BUTT.

BUILT BY B. & S. 1883  
STEEL UNDERFRAME & VESTIBULE APPLIED 1922.

# S. P. & S. OFFICIAL CAR No 99.

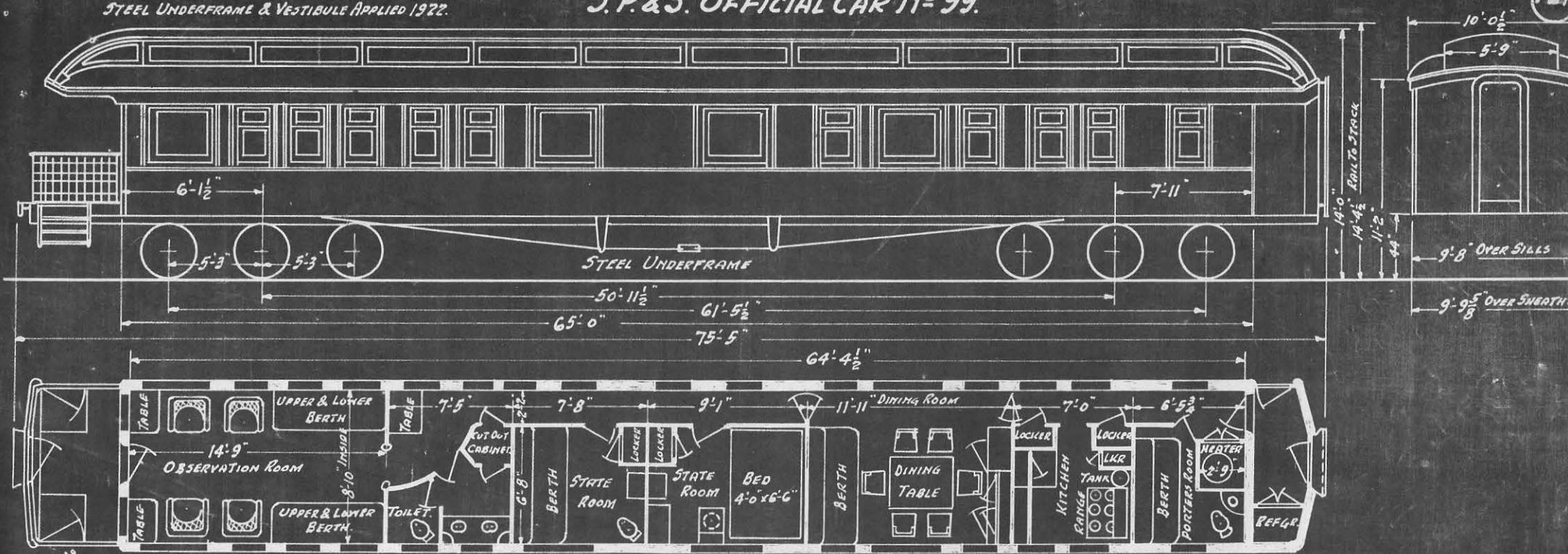

5-26-43  
Rev. 6-1-36  
7-8-25 (Rev. 3-1-26)

WEIGHT	139 260 LBS.	TRUCK CENTERS	50'-11 1/2"	AIR BRAKE	18" x 12" CYL	NEW YORK.	FINISH EXTERIOR	GROOVED SHEATHING
LENGTH OVER FRAMING	65'-0"	WHEEL BASE TRUCK	10'-6"	" SIGNAL	"	"	" INTERIOR	MAHOGANY NAT. FINISH
" " BUFFERS	75'-5"	" " TOTAL	61'-5 1/2"	HEATER	DOUBLE COIL	BAKER	" HEAD LINING	VENEER PAINTED.
WIDTH " FRAMING	9'-8"	WHEELS	STEEL 36" DIA.	HEATER PIPING	GOLD DIRECT 5YM.	512 FT. 1 1/2"	LIGHTING	AXLE GEN. ELECTRIC
" " CROWN MLDG.	10'-0 1/2"	JOURNALS	SIZE 5" x 9"	KIND OF TRUCK	METAL FACED.		DRAFT GEAR	MINER

BUILT BY B. & S. 1905.  
STEEL UNDERFRAME APPLIED 1925.

# AIR BRAKE INSTRUCTION CAR NO B-1.

128.

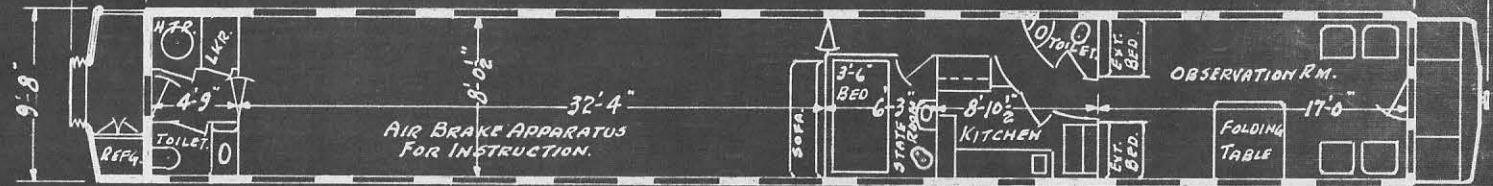
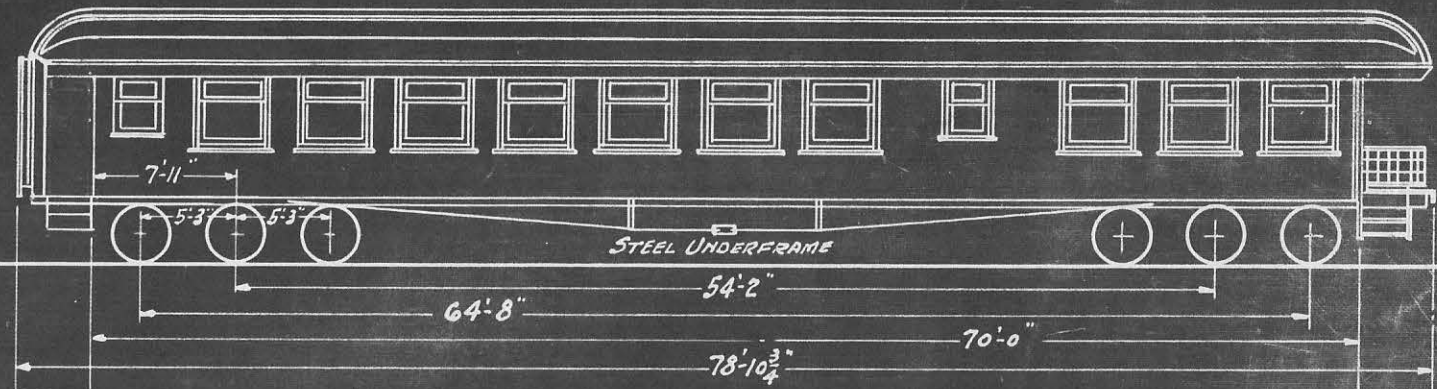
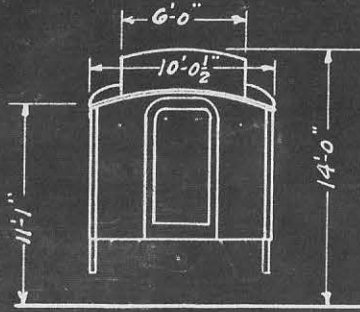

FORMERLY CAR NO 7573. A.F.E 26578.

6-1-25. REV. 3-1-26. REV. 6-1-30. 5-26-43

WEIGHT	162000 LBS.	KIND OF TRUCK	ALL METAL	FINISH-EXTERIOR	GROOVED SHEATHING
LENGTH OVER FRAMING	70'-0"	JOURNAL-SIZE	5" x 9"	" INTERIOR	MAHOGANY
" " BUFFERS	78'-10 3/4"	AIR BRAKE	2-16" x 12" CYL. U-12 VALVE. N.Y.	HEAD LINING	3-PLY VENEER PAINTED.
WIDTH " FRAMING	9'-8"	AIR SIGNAL	NEW YORK.	DRAFT GEAR	MINER
" " CROWN MLOG.	10'-0 1/2"	HEATER	B. & S. DOUBLE COIL	COUPLER	1-SHORT SHANK 2 1/2" BUTT. 1-LONG SHANK
TRUCK CENTERS	54'-2"	HEATER PIPING	1 1/4" 544 FT.		
WHEEL BASE-TRUCK	10'-6"	LIGHTING	AXLE GEN. ELECTRIC		
" " -TOTAL	64'-8"	WATER SYSTEM	GRAVITY.		
WHEELS	ROLLED STEEL 36" DIA.				



BUILT BY ST. LOUIS CAR CO. 1928.  
EQUIP. INSTALLED BY G. H. RY. 1928.

# HEATER CAR Nos 1 TO 4.

129

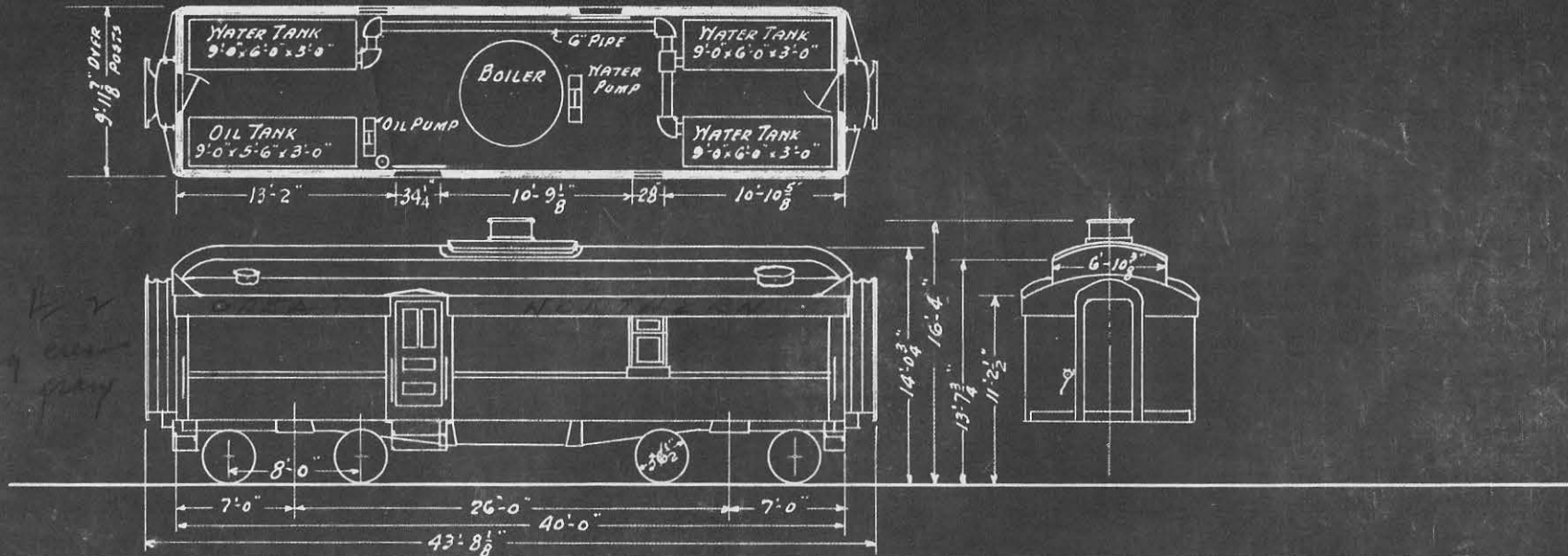

A.F.E. 34978.

8-11-28. REV. 12-14-28. REV. G. 1-30. 5-26-43

WEIGHT	161400 LBS.	TRUCK CENTER	26'-0"	BOILER	73 1/2" O.D. x 86 5/8" LONG.	FINISH - EXTERIOR	SHEET STEEL.
LENGTH OVER COUPLER FACES	43'-8 1/8"	WHEEL BASE - TRUCK	8'-0"	FLUES	480-1 1/2" DIA. x 58 1/2" "	" - INTERIOR	GROOVED SHEATHING.
" " FRAMING	40'-0"	" " TOTAL	34'-0"	OIL PUMP	WARREN SPL. 3" x 2" x 3"	BATTERY	MYAH-17.
WIDTH	9'-11 3/8"	WHEELS - ROLLED STEEL	36 1/2" DIA.	WATER PUMP	" " 4 1/2" x 2 1/2" x 4"	FUEL OIL CAPACITY	1100 GALS.
" " INSIDE	9'-4 1/4"	JOURNALS - SIZE	6" x 11"	AIR BRAKE	CYL. 18" x 12"	WATER	3570 "
LENGTH	39'-4 3/8"	KIND OF TRUCK	COMMONWEALTH C.S.	BOILER PRESS.	150 LBS.	DRAFT GEAR	MINER A-5-X.
		POR VALVES	2-1 1/2" OPEN.	HEATG. SUR. FIRE BOX	35 SQ. FT.	OIL PUMP GOV.	FISHER 3/8" ANGLE TYPE.
		STEAM GAUGE	ASHCROFT ELEC. CONTROL 300"	" " TUBES	922 "	FEED PUMP	" FISHER 1/2" ANGLE TYPE.
STEAM DRIVEN ELEC. GEN.	TYPE E.	RELIANCE JR. LOW WATER ALARM.		" " TOTAL	957 "	INSPIRATOR	HANCOCK No 25.

BUILT BY G.M. ST. PAUL SHOPS-1929

# HEATER CAR NO 5

130

BUILT FROM OLD DINER NO 1001

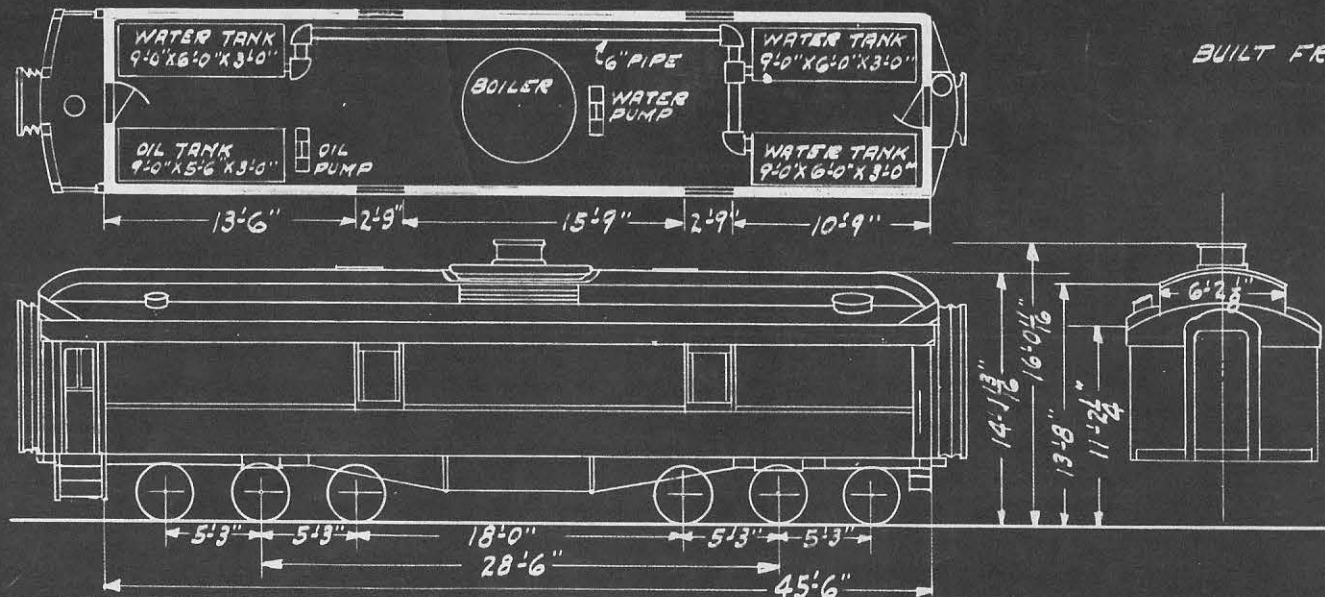

A.F.E. 39894

RELIANCE JR LOW WATER ALARM.

WEIGHT LIGHT	17500 LBS	WHEELS - ROLLED STEEL	36" DIA.	WATER PUMP	4 1/2" X 2 3/4" X 4" WARREN	FINISH INTERIOR	GROOVED SHEATH.
LENGTH OVER FRAMING	45'6"	JOURNAL SIZE	5 X 9"	AIR BRAKE	CYL-18" X 12"	BATTERY	EKIDE-M. VAH-17
WIDTH	9'8"	KIND OF TRUCK	METAL LEADED 6-WHEEL	CLASP BRAKES	SIMPLEX.	FUEL OIL CAPY	1100 GAL.
" INSIDE	8'10 1/8"	POP VALVES	2-1 1/2" SAFETY	BOILER PRESSURE	150# PR.	WATER	3570 "
LENGTH	44'-10 1/2"	STEAM GAUGE	ASHCROFT	HEATING SURFACE	FIRE BOX - 36-SQ-FT.	DRAFT GEAR	MINER-A-5-P
TRUCK CENTERS	28'6"	BOILER	72" I.D. VERT.	" " TUBES	901-SQ-FT.	OIL PUMP GOVERNOR	FISHER
" WHEEL BASE	10'6"	FLUES	356-2" TUBES.	" " TOTAL	937-SQ-FT.	FEED PUMP	" FISHER
TOTAL	39'0"	OIL PUMP	3" X 2" X 3" WARREN	FINISH EXTERIOR	SHEET STEEL	INSPIRATOR	TYPE-25 HANCOCK

11-21-29 Rev. G.1.30. 5-26-43

CAR NOS.	BUILDER	YEAR
# 6 & 7.	A.C.F.C.	1913.

# HEATER CARS No. 6 & 7.

Conv. From 200, 201 IN 1943.

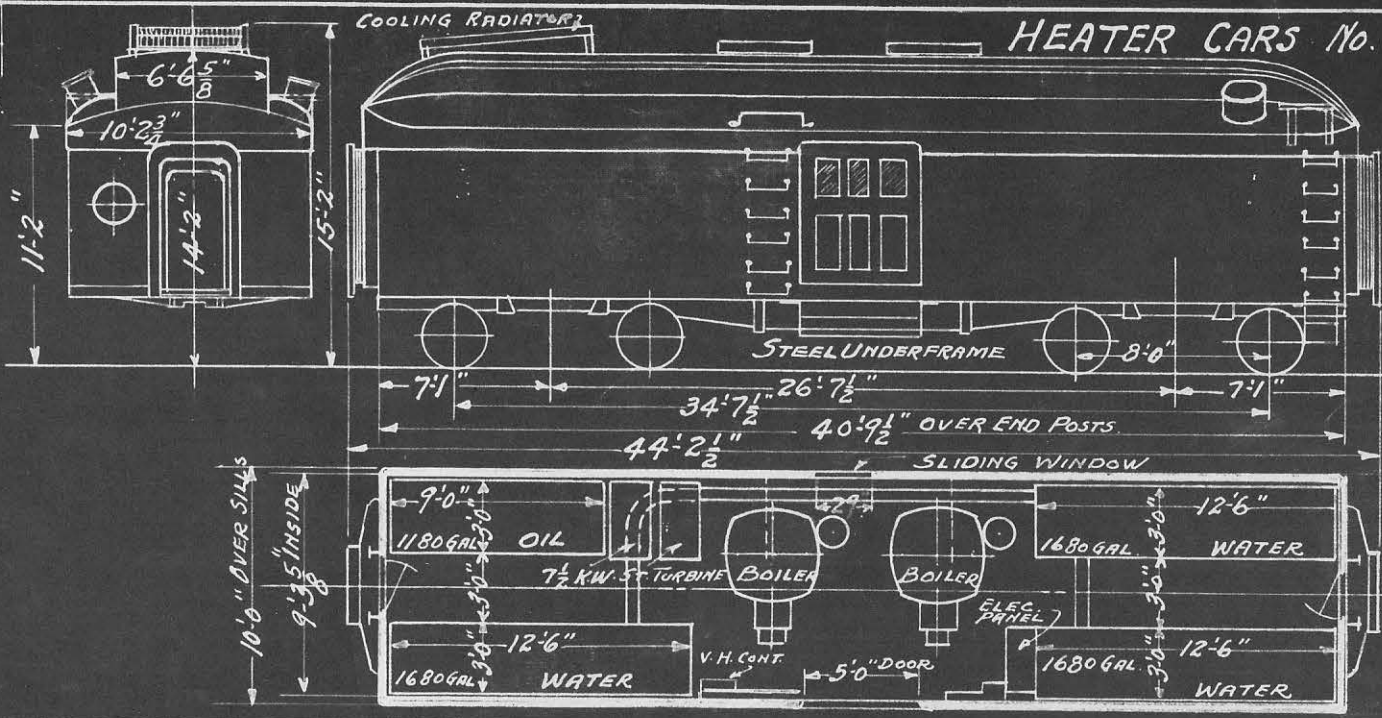

A.F.E. 32887, 65755

2-12-43 5-26-43

WEIGHT	LOADED 172 300 LBS. LIGHT 120 820 "	TRANSOM CENTERS	26'-7 <sup>1</sup> / <sub>2</sub> "	AIR BRAKE, 16"x12."	SI TRIPLE	OUTSIDE FINISH,	STEEL PLATE
LENGTH	OVER FRAMING 40'-9 <sup>1</sup> / <sub>2</sub> "	TOTAL WHEEL BASE	34'-7 <sup>1</sup> / <sub>2</sub> "	BATTERY		INSIDE	" " "
"	" BUFFERS 44'-2 <sup>1</sup> / <sub>2</sub> "	TRUCK	" " 8'-0"	HEATING	VAPOR.	OIL CAPY	1180 GAL.
WIDTH	" FRAMING 10'-0"	WHEELS, ROLLED STEEL	36 <sup>1</sup> / <sub>2</sub> "	BOILERS - CLARKSON	CFK-4225-2A	WATER	5040 "
"	" CROWN MLDG 10'-2 <sup>3</sup> / <sub>4</sub> "	TRUCKS, CAST STEEL.		LIGHTING	ELECTRIC	DRAFT RIGGING	FARLOW.
"	INSIDE 9'-3 <sup>5</sup> / <sub>8</sub> "	JOURNALS SIZE,	6"x11"			COUPLER. SS. 5"x7" MAJOR,	9 <sup>1</sup> / <sub>2</sub> " FACE.



Built St. Cloud Shops - 1944.

40 Ft. Box - Express Cars No. 2500 to 2524 No. 2500 Only.

Weight - 43500 lbs.  
 \*Items thus, made of aluminum.  
 ⊗ Outside sheathing 1/8" aluminum, stenciled in "Scotchlite".

132

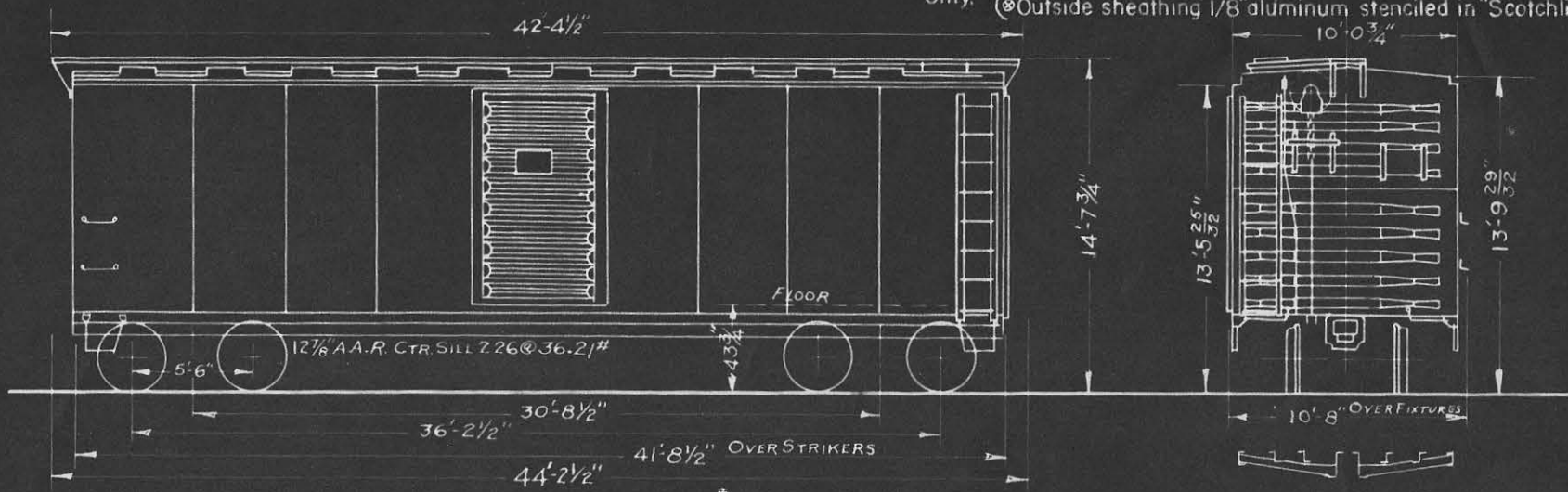

AFE 62672

Weight $\Delta$ _____ 45685 lbs	Camel Doors* _____ Steel	Side Bearings _____ Barber Top Hung	Side Framing - Body _____ Steel
Capacity - Nominal _____ 100000 "	Creco 4th Point Brake Beam Supports _____	Brake Beam Hanger _____ AAR Loop Type	Defect Card Holder _____ Apex
Cubic Contents _____ 3727 Cu. Ft.	Journals _____ 5 1/2" x 10"    Wheels _____ 33" - 1 Wear	Brake Beam Hanger Retainer _____ Azee	Brake Chain _____ Herculay
Length Inside _____ 40'-6"	Couplers - Both Oper. _____ 6-1/4" x 8"	Air Brake Type "AB-1B" _____ 10" x 12"	Sheathing ⊗ Inside & Outside 5/8" Plywood
Width _____ 9'-2"	Coupler Yoke - C.S. _____ Coupler Release Imp.	Handbrake _____ Universal	Air Signal Line _____
Height _____ - Clear _____ 10'-0"	Steel Ends* _____ Murphy W Post & Welded.	Slack Adjuster _____ Universal	Steam Heat Line _____
Side Door - Clear Ht. _____ 9'-6 9/16"    Width _____ 6'-0"	End Doors _____ None	Brake Step* _____ Apex	Timken Roller Bearings _____
Length Over End Sill L's _____ 40'-8 1/4"	Side Plates _____ Yoder	Bottom Rod Support _____ Creco	
Kind Of Trucks - Cast Steel _____ ASF-A3	Roof* _____ Murphy All Steel    Riveted	Coupler Cent. Device _____ Std. Ry. Equip Co	
Truck Boister _____ Cast Steel	Ceiling _____ 1/4" Plywood	Draft Gear _____ Miner 22XB	

5-14-45.